



GRAVELLY®

CLARKE-GRAVELLY CORPORATION
A Studebaker-Worthington Company

OPERATOR'S MANUAL

NAME: WALKER KICK STAND

PART NUMBER(S): 22474

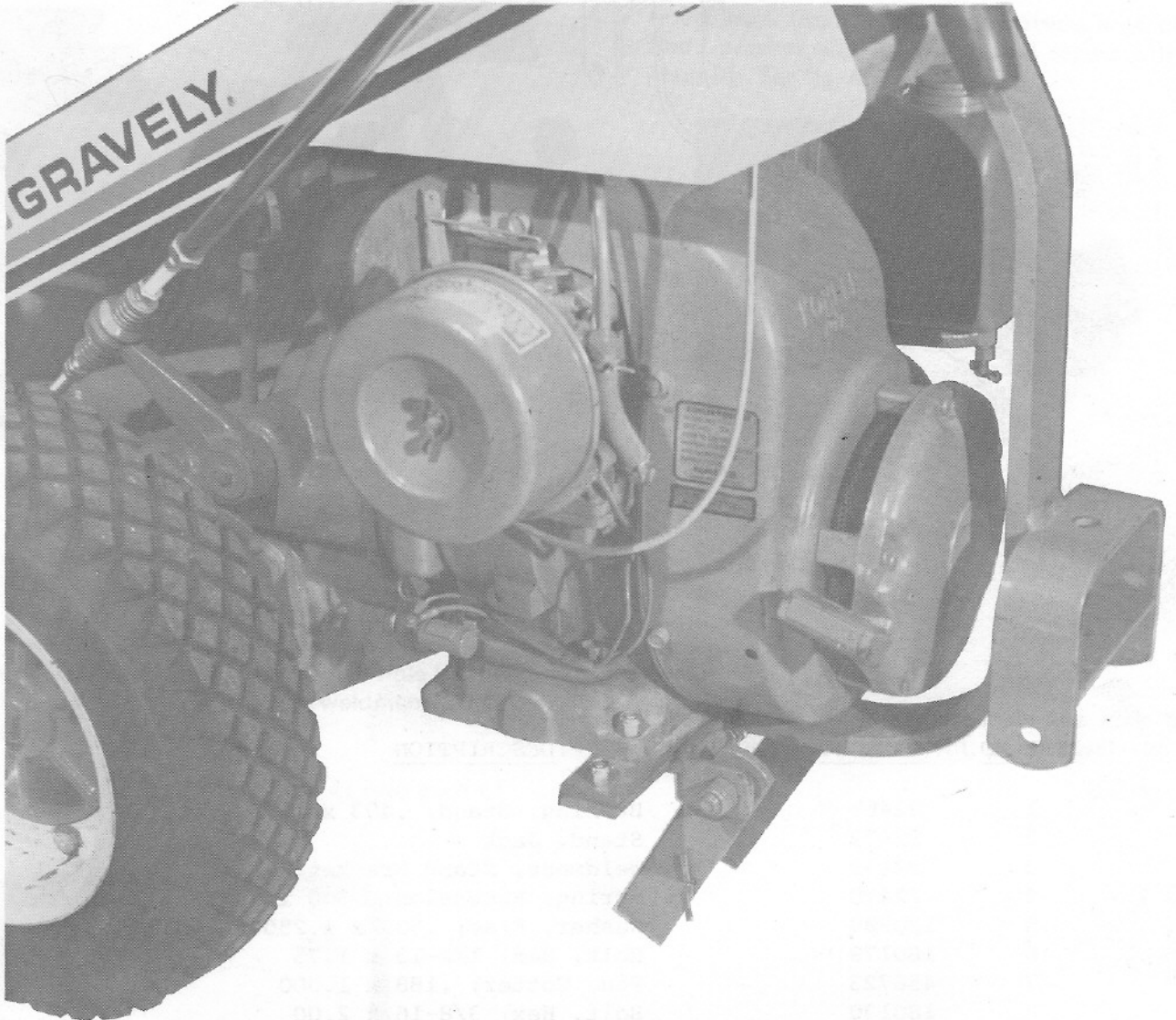

To continue its program of quality and design improvement, the manufacturer reserves the right to change specifications, designs and prices without notice and without incurring obligation

Form 22475 (1-78) Printed in U.S.A.

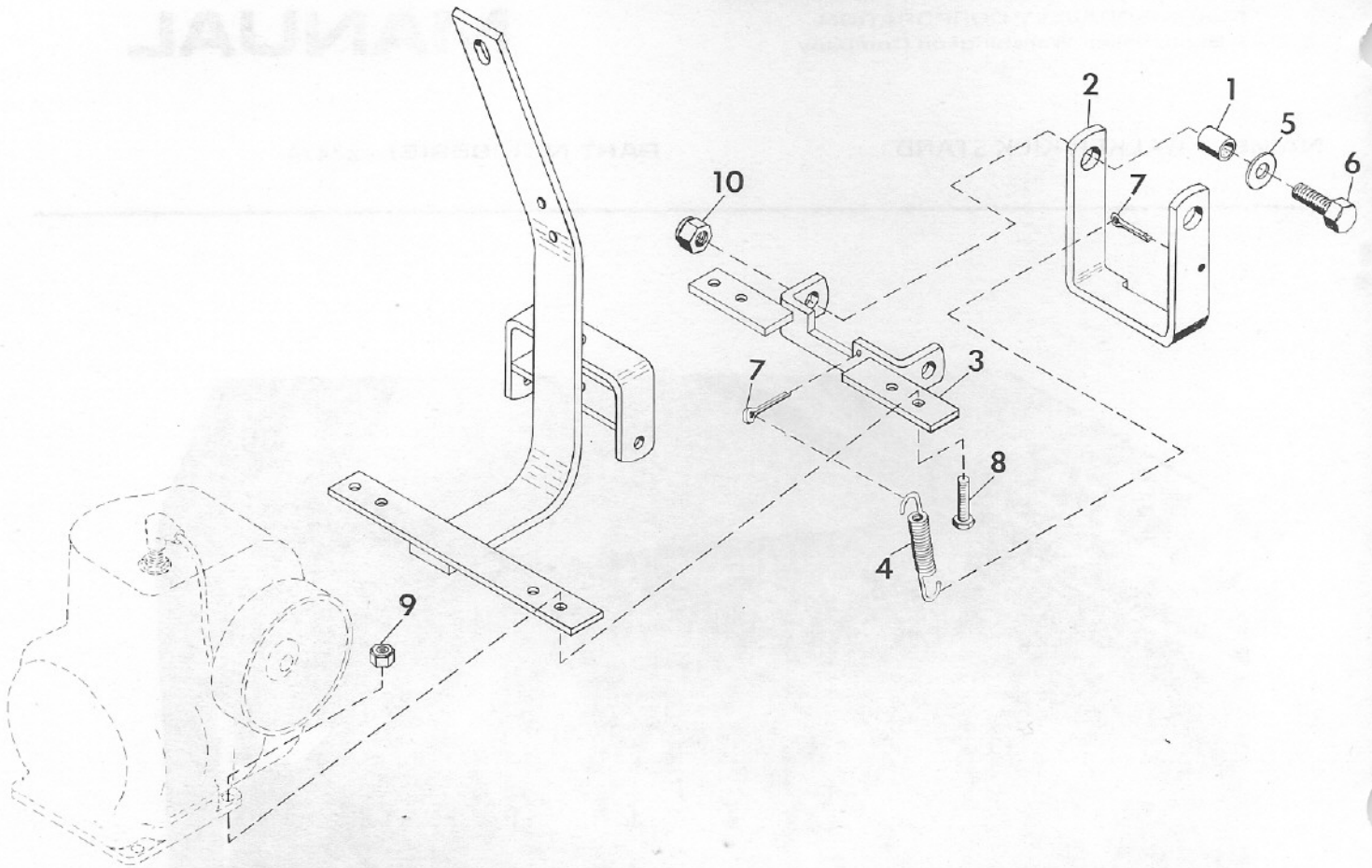

<u>ITEM NO.</u>	<u>PART NO.</u>	<u>DESCRIPTION</u>
1	22469	Bushing, Stand; .493 x .675 x .65
2	22472	Stand, Jack
3	22473	Weldment, Stand Bracket
4	22470	Spring, Extension; .500 x .2.75 x 20 Lb/in
5	120389	Washer, Flat; .500 x 1.250 x .083
6	180179	Bolt, Hex; 1/2-13 x 1.75
7	456723	Pin, Cotter; .188 x 1.000
8	180130	Bolt, Hex; 3/8-16 x 2.00
9	456004	Nut, Hex; 3/8-16 Washer Insert
10	435507	Nut, Lock; 1/2-13 Washer Insert

ASSEMBLY

1. Lay the stand bracket weldment (item 3) and jack stand (item 2) out with the cut-out up and align the bolt holes.
2. Insert a bushing (item 1) into each of the holes in jack stand.
3. Slide a washer (item 5) on bolt (item 6).
4. Put the bolt with washer through jack stand bushing and stand bracket weldment and secure with nut (item 10). See fig. 2.

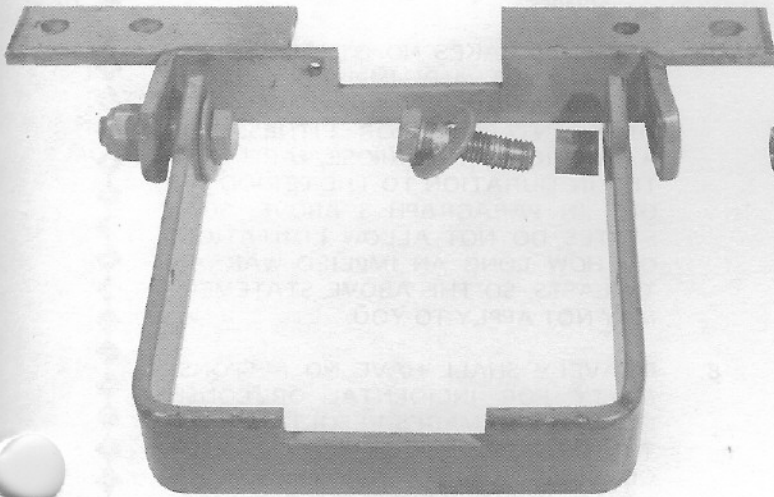

Fig. 2

5. Insert a cotter pin (item 7) in the small hole of the jack stand and secure by bending the protruding ends. The eye of the cotter pin goes to the inside.
6. Insert a cotter pin (item 7) in the small hole beside the cut-out of the stand bracket weldment. The eye goes to the inside.
7. Hook the ends of the spring (item 4) into each of the cotter pins eyes.

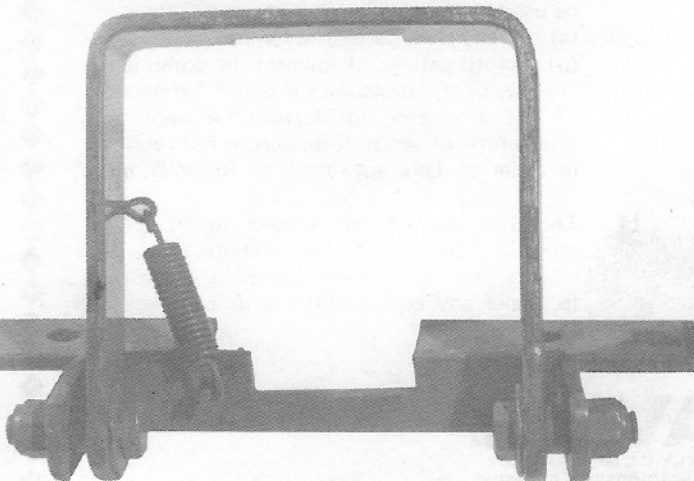

Fig 3

INSTALLATION

1. Remove the nuts and bolts from each side of the tractor engine securing rear hitch weldment to engine.
2. Position the kick stand assembly directly under the rear hitch so the rear hitch fits the cut-out of the stand bracket.
3. Insert the bolts removed through stand bracket, rear hitch and engine and secure with nut.
4. Insert bolt (item 8) through outside hole of the stand bracket and rear hitch and secure with nut (item 9). See fig. 4.

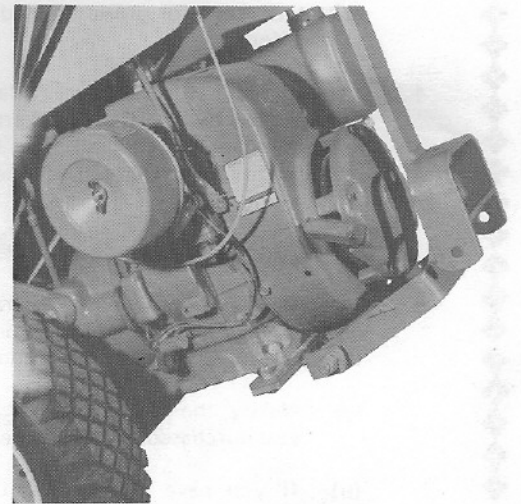

Fig. 4

MAINTENANCE

Little maintenance is required on the kick but periodic light oiling of the pivot points will aid in operation.

GRAVELY.

ATTACHMENT LIMITED WARRANTY

This Limited Warranty is issued by Clarke-Gravely Corporation, Gravely Division, and consists of the following terms:

1. Only the original purchaser of new Gravely manufactured attachments is covered by this Warranty.
2. This Warranty covers repair or replacement of parts manufactured by Gravely which are defective in material or workmanship. Gravely will pay for parts and labor only.
3. The Warranty starts the date of purchase and lasts for NINETY (90) DAYS for attachments used in Rooper applications, and TWELVE (12) MONTHS for products used in all other applications.
4. Some components of Gravely attachments are not covered by the Gravely Warranty. These components are covered by the original manufacturer's warranty. They are:
 - (a) Tires - Goodyear, Goodrich, Armstrong, General and Firestone
5. To obtain warranty service on Gravely attachments including components not manufactured by Gravely, use this procedure:
 - (a) Notify the Gravely dealer from whom you purchased the attachment.
 - (b) If you have moved and it is not convenient to notify the selling dealer, notify the nearest Gravely dealer. You should supply this dealer with a copy of the bill of sale as proof of the date of purchase.
 - (c) Make arrangements to have the attachment delivered to the dealer (refer to paragraph 6(a) below).
 - (d) If you have any questions concerning the Gravely Warranty, they should be referred to:

Gravely
Clarke-Gravely Corporation
A Studebaker-Worthington Company
One Gravely Lane
Clemmons, N. C. 27012
Attn: Manager of Customer Services
 - (e) Warranty service on Gravely attachments must be performed by an authorized Gravely dealer or Gravely factory branch.
6. This Warranty does not cover the following:
 - (a) Transportation between owner's home or place of business and the dealership. If the dealer provides the transportation of the attachment, he will charge the owner his usual rate for such service.
 - (b) Normal maintenance services and normal replacement of items such as belts lubricants, mower, plow or cultivator blades.
7. GRAVELY MAKES NO OTHER EXPRESS WARRANTIES. ANY IMPLIED WARRANTIES, INCLUDING WARRANTIES AS TO MERCHANTABILITY OR FITNESS FOR A PARTICULAR PURPOSE, ARE LIMITED IN DURATION TO THE PERIOD SET OUT IN PARAGRAPH 3 ABOVE. SOME STATES DO NOT ALLOW LIMITATIONS ON HOW LONG AN IMPLIED WARRANTY LASTS, SO THE ABOVE STATEMENT MAY NOT APPLY TO YOU.
8. GRAVELY SHALL HAVE NO RESPONSIBILITY FOR INCIDENTAL OR CONSEQUENTIAL DAMAGES RESULTING FROM THE BREACH OF ANY WARRANTY, INCLUDING, BUT NOT LIMITED TO, INCONVENIENCE, RENTAL OR PURCHASE OF REPLACEMENT EQUIPMENT, LOSS OF PROFITS OR COMMERCIAL LOSS. SOME STATES DO NOT ALLOW THE EXCLUSION OR LIMITATION OF INCIDENTAL OR CONSEQUENTIAL DAMAGES, SO THE ABOVE LIMITATION OR EXCLUSION MAY NOT APPLY TO YOU.
9. This Warranty gives you specific legal rights, and you may have other rights which vary from state to state.
10. A Gravely registration card is supplied with each Gravely attachment. Please complete the card and return it to Gravely at the address listed on the card. The registration card will be used by Gravely for:
 - (a) Recording date of purchase.
 - (b) Notification of owners in compliance with the Consumer Product Safety Act, should any notification be necessary.The return of registration card is not required in order to take advantage of this Warranty.
11. This Warranty is not subject to change or modification by anyone, including Gravely dealers and no Gravely dealer is authorized to make any representations or promises on Gravely's behalf.