



**VAC DRIVE KIT
12-HP, 17-HP & 19-HP
KOHLER ENGINES**

FORM NO: 38870 (9-84)

PART NO: 38869

PRINTED IN USA

Installation

1. Remove the hardware which attaches grass deflector.
2. Remove the screws which attaches the grass screen to the flywheel, and remove the grass screen.
3. Attach the drive adaptor to the flywheel with four 3/8-16x1 bolts and lock washers.
4. Put the new grass screen on the flywheel aligning the holes. Secure with four screws. Check instructions packed with the screen for specific details.
5. Put the key in the keyway in the drive adaptor.
6. Slide the sheave on the drive adaptor. Note the orientation of the sheave: Single cylinder engine - hub first;
Twin cylinder engine - groove first.
7. Secure the sheave with a flat washer, lock washer, and 3/8-16x1 bolt.

Illustrated Parts and Parts Lists

12 H.P. Kohler Engines

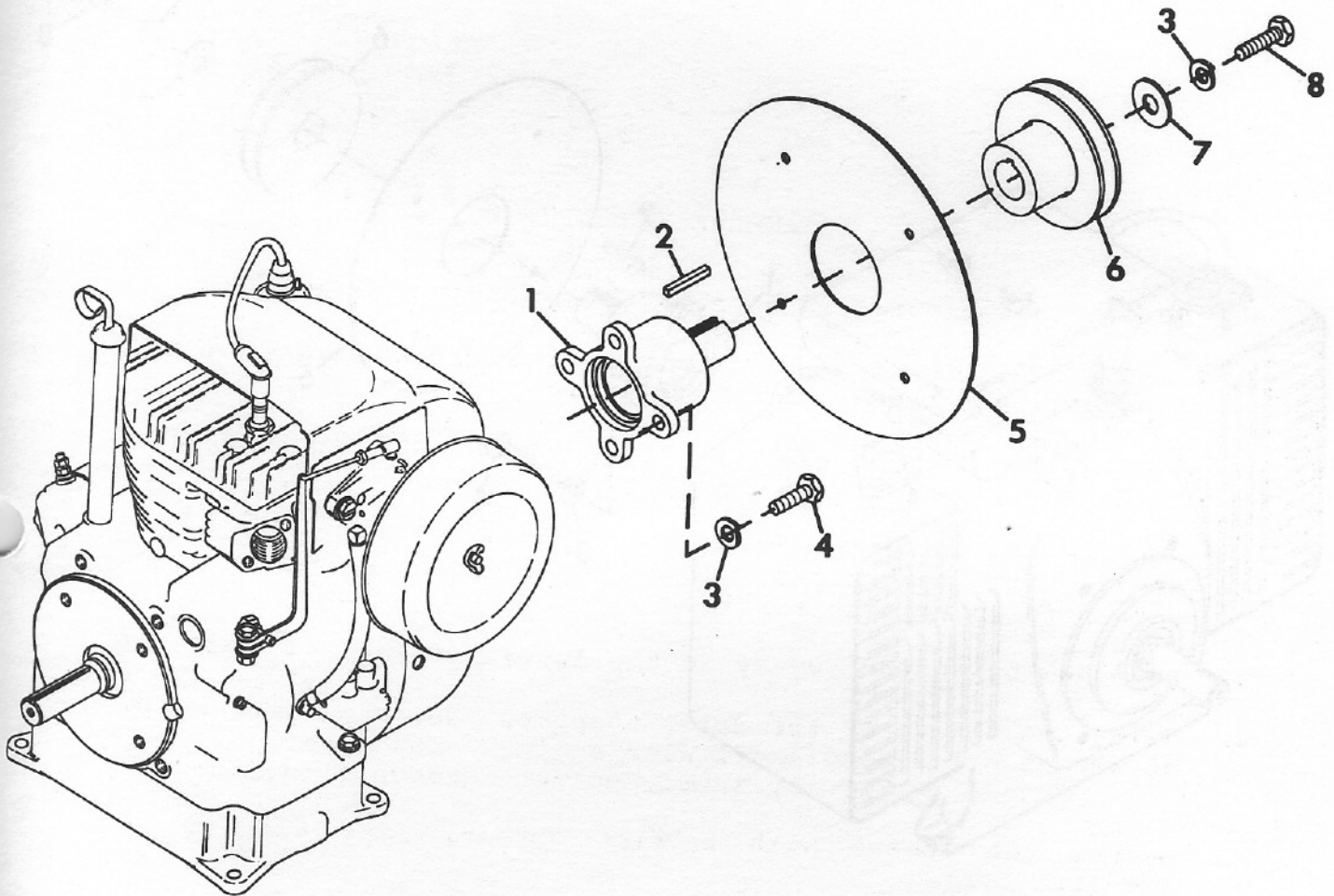

ITEM NO.	PART NO.	QTY.	DESCRIPTION
1	37014	1	Adaptor, Drive Kohler
2	18345	1	Key, Square .250x1.250
3	120381	5	Washer, Lock 3/8
4	180122	4	Bolt, Hex 3/8-16x1.00
5	37055	1	Screen, Grass Kohler
6	36963	1	Sheave, Engine
7	37515	1	Washer, Flat 1.25x.50 Hard
8	180124	1	Bolt, Hex 3/8-16x1.25

17 H.P. and 19 H.P. Kohler Engines

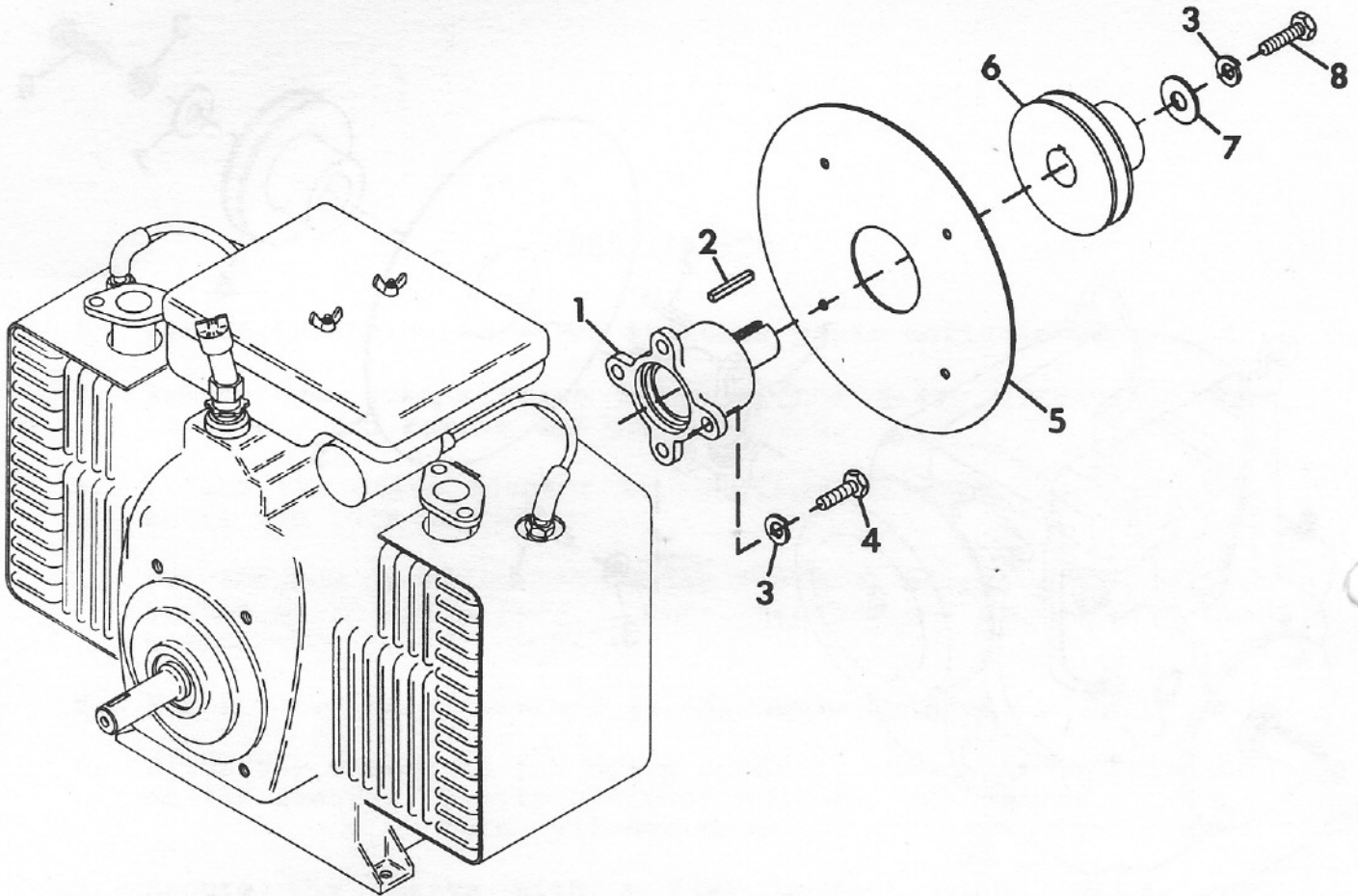

ITEM NO.	PART NO.	QTY.	DESCRIPTION
1	37014	1	Adaptor, Drive Kohler
2	18345	1	Key, Square .250x1.250
3	120381	5	Washer, Lock 3/8
4	180122	4	Bolt, Hex 3/8-16x1.00
5	37055	1	Screen, Grass Kohler
6	36963	1	Sheave, Engine
7	37515	1	Washer, Flat 1.25x.50 Hard
8	180124	1	Bolt, Hex 3/8-16x1.25