

GRAVELLY OPERATOR'S MANUAL

NAME: ROTARY CULTIVATOR

PART NUMBER(S): 22162

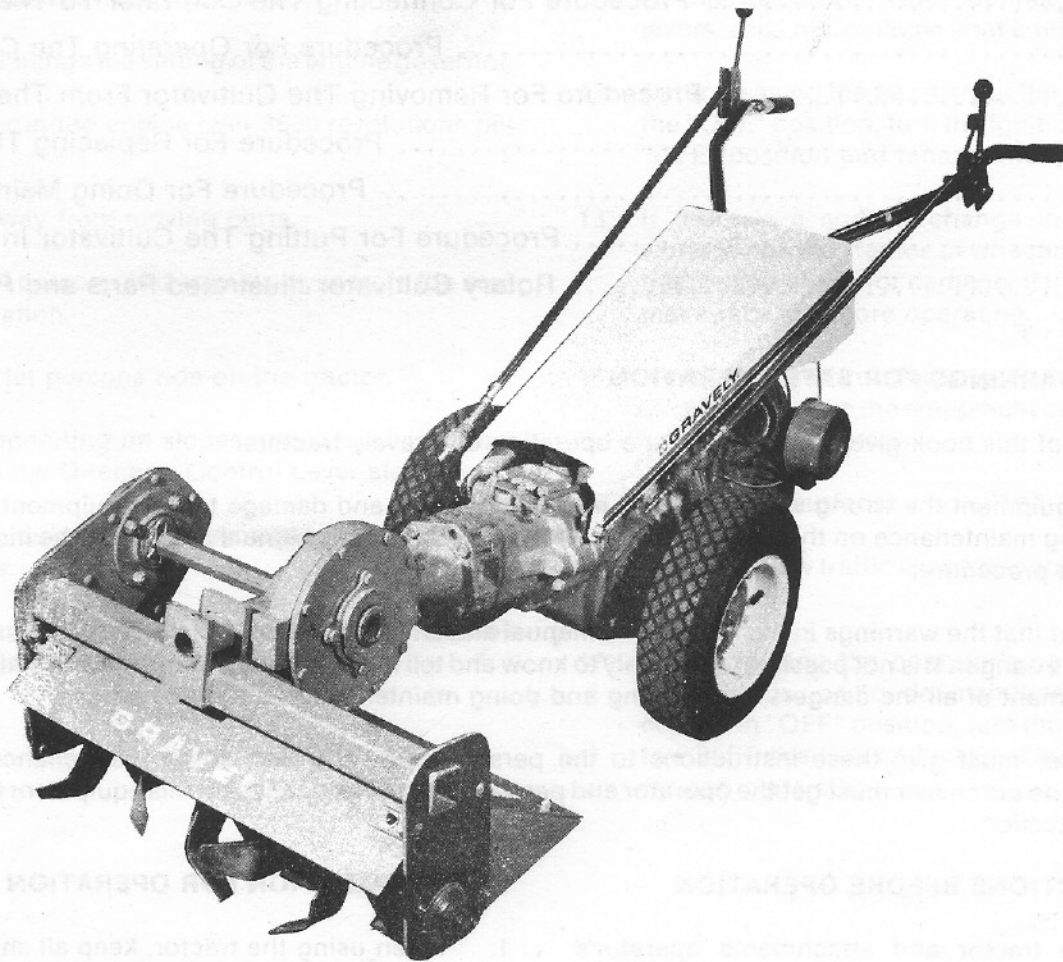

The Rotary Cultivator is for use with the Gravely two wheel tractors. The Rotary Cultivator must have the Plow/Cultivator Drive.

All reference to left side, right side, front and rear are given from the operator's position.

To continue its program of quality and design improvement, the manufacturer reserves the right to change specifications, designs and prices without notice and incurring obligation.

Form No. 25163 (11-78)

Printed in U.S.A.

CONTENTS

1.0	Warnings for Safe Operation
2.0	Bolt Torque Specifications
3.0	Procedure For Connecting the Plow/Cultivator Drive to the Cultivator
4.0	Procedure For Preparing The Rotary Plow Drive For Connecting To The Cultivator
5.0	Procedure For Connecting The Cultivator To The Tractor
6.0	Procedure For Operating The Cultivator
7.0	Procedure For Removing The Cultivator From The Tractor
8.0	Procedure For Replacing The Tines
9.0	Procedure For Doing Maintenance
10.0	Procedure For Putting The Cultivator In Storage
11.0	Rotary Cultivator Illustrated Parts and Parts List

1.0 WARNINGS FOR SAFE OPERATION

This section of this book gives warning for safe operation of Gravely tractors.

Using this equipment the wrong way can cause injury to persons and damage to the equipment. Persons using or doing maintenance on this equipment must read this Operator's Manual and follow the instructions using correct procedure.

It is important that the warnings in this Operator's Manual and any other Gravely instruction book do not list every possible danger. It is not possible for Gravely to know and tell the operator or person doing maintenance on the equipment of all the dangers in operating and doing maintenance on the equipment.

The purchaser must give these instructions to the persons operating and doing maintenance on this equipment. The purchaser must get the operator and person doing maintenance on this equipment to use eye and foot protection.

1.1 INSTRUCTIONS BEFORE OPERATION

1. Read the tractor and attachments operator's manual carefully before operating or doing maintenance.
2. Learn the location and function of all tractor and attachment controls.
3. Know how to use the controls to stop the tractor and attachment in a short time.
4. Never permit children to operate or ride on the tractor.
5. Use Caution with gasoline. Gasoline is very flammable. Keep gasoline in a clean and tight container. Keep gasoline away from flames or hot items. Never put gasoline in the fuel tank while the engine is running or hot. Clean any gasoline leakage before starting the engine.

1.2 PREPARATION FOR OPERATION

1. When using the tractor, keep all shields, guards and safety interlock switches in the correct position.
2. Wear strong shoes and clothing that is not loose when operating the tractor. Make sure your feet and eyes have protection.
3. Before starting the engine, put the Direction Control Lever in neutral and PTO Control in "OFF" position.
4. Do not use the tractor where the work area is too dark for the operator to see.
5. Keep the tractor in good operating condition. Do the maintenance as shown in the tractor Operator's Manual.

6. Never operate the tractor or attachment when there is damage to any part or any part is not in the correct position. Replace all parts when damaged or missing before operating.
7. USE ONLY GRAVELY ACCESSORIES AND ATTACHMENTS OR EQUIPMENT shown by Gravelly to be correct for use with the tractor.

1.3 PROCEDURE FOR OPERATION

1. Do not change the setting of the engine governor.
2. Do not run the engine over 3600 revolutions per minute.
3. Keep away from moving parts.
4. Keep all persons and animals away from the area of operation.
5. Do not let persons ride on the tractor.
6. When operating on slopes, use a low speed and engage the Direction Control Lever slowly.
7. Always look for and keep away from holes and hazards.
8. Use more caution when moving backward. Look for persons and danger in the way.
9. After hitting an item, stop the tractor and engine and check for damage. If there is damage, make repairs before restarting.
10. Operate equipment only when in the operator's position.
11. When moving the equipment on a transport, connect the tractor chassis and tractor rear hitch to the transport. Never connect from control levers, rods or like items, that could be damaged.
12. Before leaving the tractor, put the PTO Control in the "OFF" position, turn the Ignition Switch to the "OFF" position and remove the Ignition Key.
13. If there is a sudden change in the sound or vibration of the tractor or attachments, stop the tractor and check for damage. If there is damage, make repairs before operating.
14. Never start and run the engine inside a building except to remove the equipment outside. Exhaust fumes are dangerous.
15. Go slow on surfaces where the tractor can slide.
16. Always follow traffic laws while going on or near a road.
17. Before leaving the operator's position to make adjustments, or to do maintenance, put PTO control in "OFF" position, turn the ignition switch to "OFF" position and wait until the engine and moving parts stop.

2.0 BOLT TORQUE SPECIFICATIONS

This section gives the torque specifications for tightening the bolts used to assemble this equipment. Tighten the bolts to the torque listed unless shown differently.

BOLT SIZE	BOLT TORQUE SPECIFICATIONS	
	FOOT POUNDS (ft. lbs.)	NEWTON METERS (N.m)
1/4"	7	9.5
5/16	14	19
3/8"	25	34
7/16"	40	54
1/2"	60	82
9/16"	83	113
5/8"	120	163
3/4"	200	271

3.0 PROCEDURE FOR CONNECTING THE PLOW/CULTIVATOR DRIVE TO THE CULTIVATOR

This section gives the procedure for connecting the Plow/Cultivator Drive to the Cultivator.

1. Put the Plow/Cultivator Drive on the Shaft with the Grease Fitting towards the Shaft as shown in figure 3.0-1.

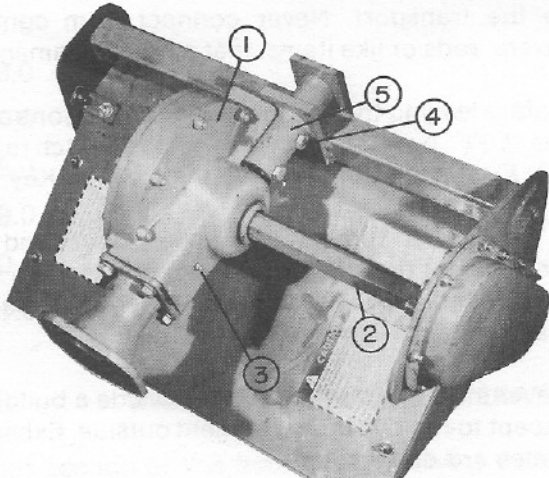

- | | |
|---------------------------|-------------------|
| 1 - Plow/Cultivator Drive | 4 - Bolt |
| 2 - Shaft | 5 - Frame Support |
| 3 - Grease Fitting | |

Figure 3.0-1

2. Fasten the Plow/Cultivator Drive to the Frame Support with the 1/2" x 2-3/4" Bolts.

4.0 PROCEDURE FOR PREPARING THE ROTARY PLOW DRIVE FOR CONNECTING TO THE CULTIVATOR

This section gives the procedure for preparing the Rotary Plow Drive for connecting to the Cultivator. See figure 4.0-1. for the parts that must be removed from the Plow Drive.

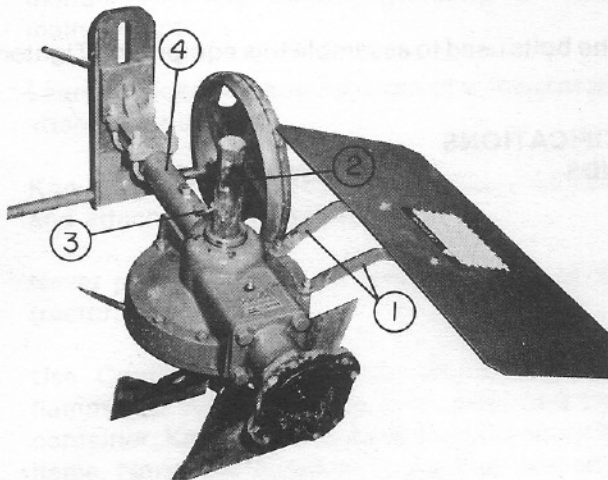

- | | |
|----------------------|--------------------------|
| 1 - Adjusting Straps | 3 - Depth Adjusting Pin |
| 2 - Rotor Shaft | 4 - Depth Wheel Assembly |

Figure 4.0-1

1. Remove the two bolts that fasten the Adjusting Straps to the Plow Drive and remove the Dirt Shield. Reinstall the bolts in the drive and tighten.
2. Remove the Depth Adjusting Pin from the Rotor Shaft and remove the shaft from the drive.
3. Remove the two bolts that fasten the Depth Wheel Assembly to the drive and remove the assembly.
4. The Plow Drive will be as shown in figure 4.0-2.

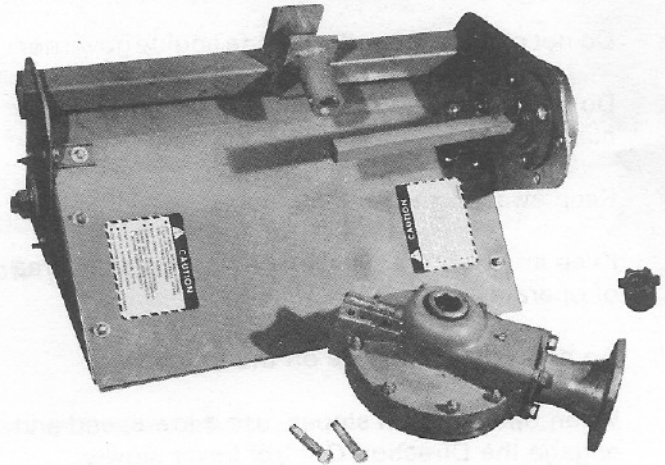

Figure 4.0-2

5. Connect the Plow Drive to the Rotary Cultivator as shown in section 3.0.

5.0 PROCEDURE FOR CONNECTING THE CULTIVATOR TO THE TRACTOR

This section gives the procedure for connecting the Cultivator to the tractor.

1. Put the Attachment Dog on the Power Take-Off (PTO) Shaft of the Tractor as shown in figure 5.0-1.

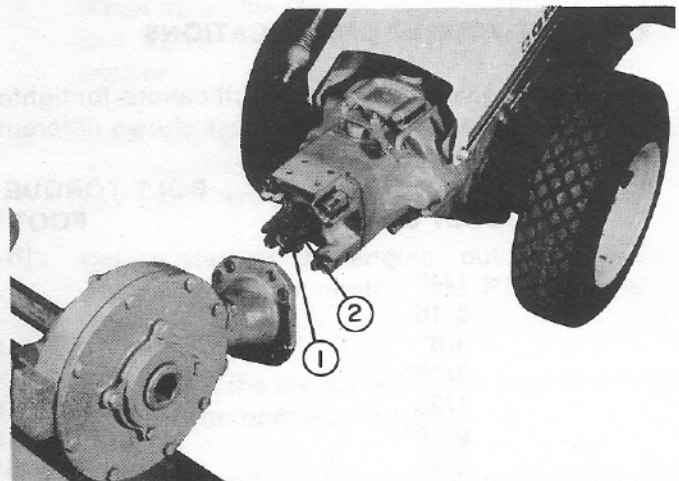

- | |
|--------------------|
| 1 - PTO Shaft |
| 2 - Attachment Dog |

Figure 5.0-1

2. Fasten the Cultivator to the Attachment Adapter with the Attachment Bolts as shown in figure 5.0-2.

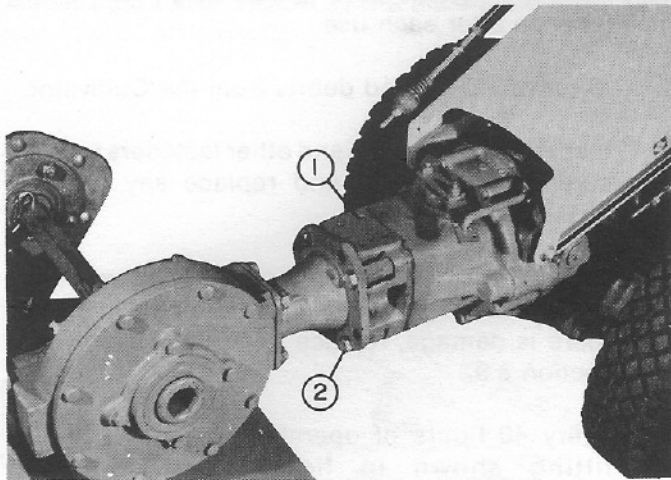

1 - Attachment Adapter
2 - Attachment Bolts

Figure 5.0-2

6.0 PROCEDURE FOR OPERATING THE CULTIVATOR

This section shows the procedure for operating the Cultivator. Read this Operator's Manual and the tractor Operator's Manual before operating. Use a slow speed until you know how to use the Cultivator.

1. Start the tractor engine and wait until the engine is running smoothly before operating.
2. Put the RANGE selector in the "LOW" position.
3. Engage the PTO.
4. Move the throttle lever to the "FAST" position.

WARNING: When the GEAR selector is engaged the Cultivator tines will rotate and can cause the tractor to move forward.

5. Put the GEAR selector in the "LOW" position.
6. Put the Direction Control lever in the "FORWARD" position.

7.0 HOW TO REMOVE THE CULTIVATOR FROM THE TRACTOR

This section gives the procedure for removing the Cultivator from the tractor.

1. Remove the Attachment Bolts that fasten the Cultivator to the Attachment Adapter and remove the Cultivator. See figure 5.0-2.
2. Remove the Attachment Dog from the PTO Shaft. See figure 5.0-1. Keep the Attachment Dog with the Cultivator.

8.0 PROCEDURE FOR REPLACING THE TINES

This section gives the procedure for replacing the Tines. Replace all the Tines at the same time.

1. Remove the Cultivator from the tractor as shown in section 7.0.
2. Remove the Tine Shaft Nut by turning the nut counterclockwise. See figure 8.0-1.

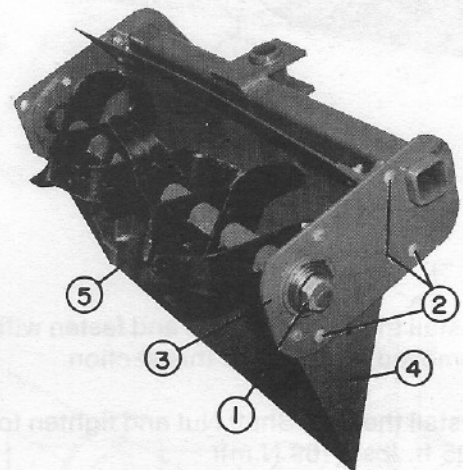

1 - Tine Shaft Nut
2 - Bolts To Be Removed
3 - Support Plate
4 - Side Shield
5 - Dirt Shield

Figure 8.0-1

3. Remove the three bolts that fasten the Support Plate to the Side Shield and the Dirt Shield and then remove the Support Plate.

NOTE: Before removing the Tines from the shaft, (next step) see the position of the Tines on the shaft.

4. Remove the Tines and Spacers from the shaft.
5. Install the Tines on the shaft with the cutting edge towards the direction the shaft rotates. The shaft rotates counterclockwise as seen from the left side.

- Put a Spacer on the shaft, a Tine and a Spacer. Put the next Tine on the shaft one position farther around the shaft than the one just installed. See figure 8.0-2. Follow this procedure until all the Tines and Spacers have been installed.

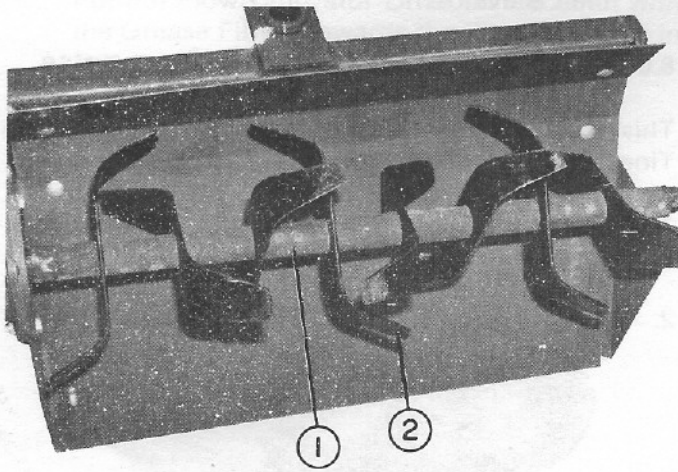

- 1 - Spacer
2 - Tine

Figure 8.0-2

- Install the Support Plate and fasten with the bolts removed in step 2 of this section.
- Install the Tine Shaft Nut and tighten to torque of 125 ft. lbs. (169 N.m).

9.0 PROCEDURE FOR DOING MAINTENANCE

This section gives the procedure for doing maintenance after each use.

- Remove all dirt and debris from the Cultivator.
- Inspect all nuts, bolts and other fasteners to make sure they are tight and replace any that are missing.
- Check the Tines to see if they are badly worn or if there is damage. If the Tines are badly worn or there is damage, replace the Tines as shown in section 8.0.
- Every 40 hours of operation, clean the grease fitting shown in figure 3.0-1 and add multipurpose grease until it shows at the shaft.

10.0 PROCEDURE FOR PUTTING THE CULTIVATOR IN STORAGE

This section gives the procedure for putting the Cultivator in storage. When the Cultivator will not be operated for three months or more, follow this procedure.

- Do the maintenance shown in section 9.0.
- To prevent rust, put paint or multi-purpose grease on any area where the paint has been removed.

11.0 ROTARY CULTIVATOR ILLUSTRATED PARTS AND PARTS LIST

This section shows the Rotary Cultivator Illustrated Parts and the Parts List. Figure 11.0-1 shows the Illustrated Parts. Figure 11.0-2 shows the Parts List.

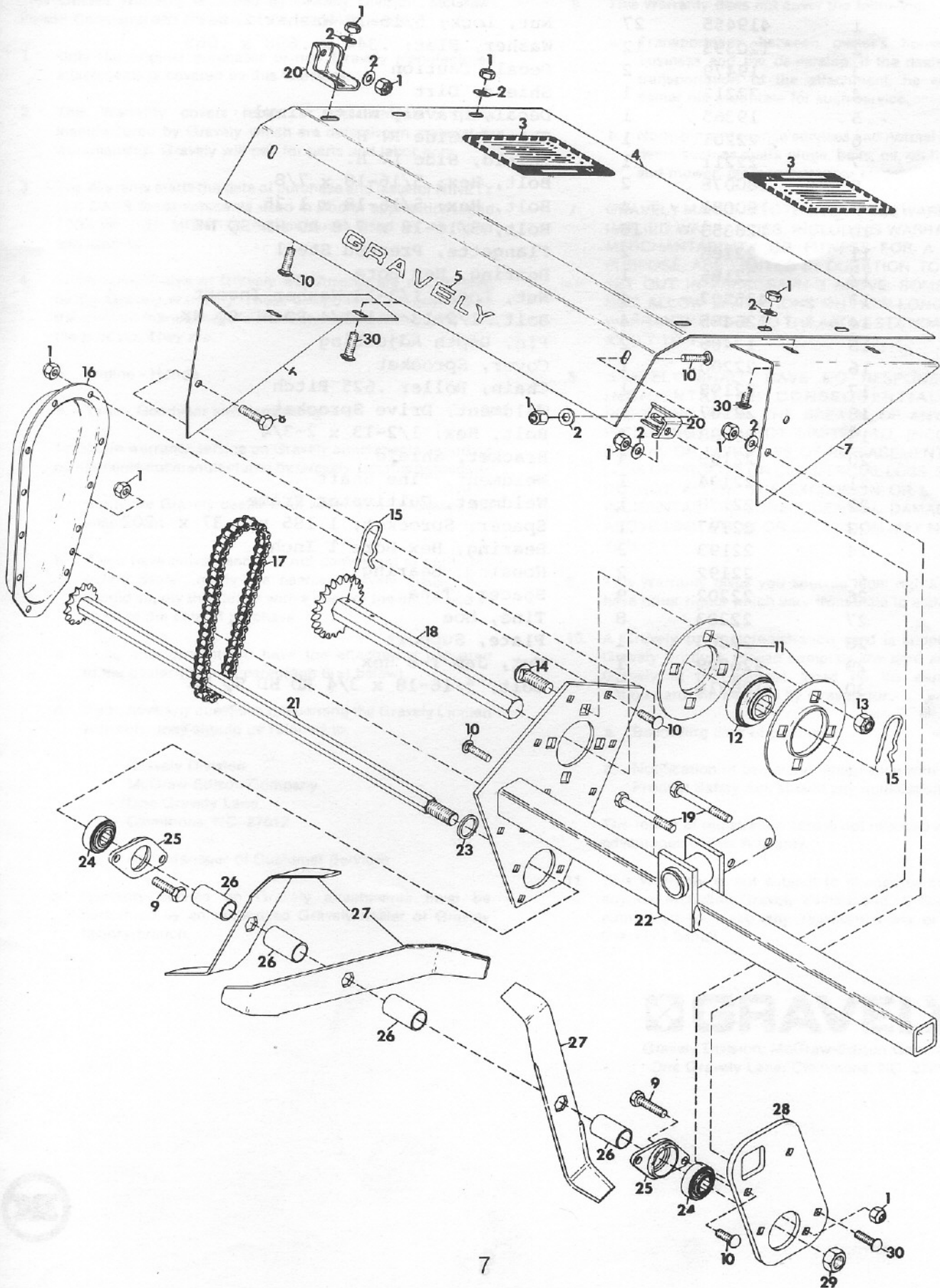

ROTARY CULTIVATOR LESS DRIVE

<u>ITEM NO.</u>	<u>PART NO.</u>	<u>QTY.</u>	<u>DESCRIPTION</u>
1	419455	27	Nut, Lock; 5/16-18 Washer Insert Hex
2	120393	12	Washer, Flat; .344 x .688 x .065
3	19479	2	Decal, Caution
4	22212	1	Shield, Dirt
5	19365	1	Decal, Gravely White Vinyl
6	22201	1	Shield, Side R. H.
7	22211	1	Shield, Side L. H.
8	180078	2	Bolt, Hex; 5/16-18 x 7/8
9	180081	4	Bolt, Hex; 5/16-18 x 1.25
10	126353	16	Bolt, 5/16-18 x 7/8 RD HD SQ NK
11	22186	2	Flangette, Pressed Steel
12	22185	1	Bearing, Hex Bore
13	435507	4	Nut, Lock; 1/2-13 Washer Insert
14	126485	4	Bolt, 1/2-13 x 1-1/4 RD HD SQ NK
15	13466	2	Pin, Depth Adjusting
16	22200	1	Cover, Sprocket
17	22198	1	Chain, Roller .625 Pitch
18	22187	1	Weldment, Drive Sprocket
19	180188	2	Bolt, Hex; 1/2-13 x 2-3/4
20	22199	4	Bracket, Shield
21	22194	1	Weldment, Tine Shaft
22	22178	1	Weldment, Cultivator Frame
23	22197	1	Spacer, Sprocket; 1.185 x 1.37 x .202
24	22193	2	Bearing, Hex Bore 1 Inch
25	22192	2	Housing, Bearing
26	22202	9	Spacer, Tine
27	22203	8	Tine, Hoe
28	22205	1	Plate, Support
29	426899	1	Nut, Jam 1-8 Hex
30	126216	5	Bolt, 5/16-18 x 3/4 RD HD SQ NK



GRAVELY ATTACHMENT LIMITED WARRANTY

This Limited Warranty is issued by Gravelly Division, McGraw-Edison Company, and consists of the following terms:

1. Only the original purchaser of new Gravelly manufactured attachments is covered by this Warranty.
2. This Warranty covers repair or replacement of parts manufactured by Gravelly which are defective in material or workmanship. Gravelly will pay for parts and labor only.
3. The Warranty starts the date of purchase and lasts for NINETY (90) DAYS for attachments used in Roofer applications, and TWELVE (12) MONTHS for products used in all other applications.
4. Some components of Gravelly attachments are not covered by the Gravelly Warranty. These components are covered by the original manufacturer's warranty, which is included with the product. They are:
 - a. Engine - Honda
 - b. Tires - Goodyear and Armstrong
5. To obtain warranty service on Gravelly attachments including components not manufactured by Gravelly, use this procedure:
 - a. Notify the Gravelly dealer from whom you purchased the attachment.
 - b. If you have moved and it is not convenient to notify the selling dealer, notify the nearest Gravelly dealer. You should supply this dealer with a copy of the bill of sale as proof of the date of purchase.
 - c. Make arrangements to have the attachment delivered to the dealer (refer to paragraph 6(a) below).
 - d. If you have any questions concerning the Gravelly Limited Warranty, they should be referred to:

Gravelly Division
McGraw-Edison Company
One Gravelly Lane
Clemmons, NC 27012

Attn: Manager of Customer Services
 - e. Warranty service on Gravelly attachments must be performed by an authorized Gravelly dealer or Gravelly factory branch.

6. This Warranty does not cover the following:
 - a. Transportation between owner's home or place of business and the dealership. If the dealer provides the transportation of the attachment, he will charge the owner his usual rate for such service.
 - b. Normal maintenance services and normal replacement of items such as spark plugs, belts, oil, oil filters, air filters, and mower, plow or cultivator blades.
7. GRAVELLY MAKES NO OTHER EXPRESS WARRANTIES. ANY IMPLIED WARRANTIES, INCLUDING WARRANTIES AS TO MERCHANTABILITY OR FITNESS FOR A PARTICULAR PURPOSE, ARE LIMITED IN DURATION TO THE PERIOD SET OUT IN PARAGRAPH 3 ABOVE. SOME STATES DO NOT ALLOW LIMITATIONS ON HOW LONG AN IMPLIED WARRANTY LASTS, SO THE ABOVE STATEMENT MAY NOT APPLY TO YOU.
8. GRAVELLY SHALL HAVE NO RESPONSIBILITY FOR INCIDENTAL OR CONSEQUENTIAL DAMAGES RESULTING FROM THE BREACH OF ANY WARRANTY, INCLUDING, BUT NOT LIMITED TO, INCONVENIENCE, RENTAL OR PURCHASE OF REPLACEMENT PRODUCTS, LOSS OF PROFITS OR COMMERCIAL LOSS. SOME STATES DO NOT ALLOW THE EXCLUSION OR LIMITATION OF INCIDENTAL OR CONSEQUENTIAL DAMAGES, SO THE ABOVE LIMITATION OR EXCLUSION MAY NOT APPLY TO YOU.
9. This Warranty gives you specific legal rights, and you may have other rights which vary from state to state.
10. A Gravelly product registration card is supplied with each Gravelly product. Please complete the card and return it to Gravelly at the address listed on the card. The registration card will be used by Gravelly for:
 - a. Recording date of purchase.
 - b. Notification of owners in compliance with the Consumer Product Safety Act, should any notification be necessary.The return of registration card is not required in order to take advantages of this Warranty.
11. This Warranty is not subject to change or modification by anyone, including Gravelly dealers and no Gravelly dealer is authorized to make any representations or promises on Gravelly's behalf.



Gravelly Division, McGraw-Edison Company
One Gravelly Lane, Clemmons, NC 27012