



PROFESSIONAL - G TRACTOR SERVICE MANUAL

⚠ SAFETY MESSAGE ⚠

The product for which you have requested information or replacement parts is not a current product. The replacement models incorporate product designs, safety features, safety instruction or warnings which represent the latest "State Of The Art" developments. For your safety and those around you please contact your nearest Ariens/Gravelly Dealer for a demonstration of the current product safety provisions and features.

NOTE

All references to "left-side," "right-side," "front," and "back" are given from the operator's position.



**Look for this symbol to point out important safety precautions.
It means — Attention! Become Alert! YOUR SAFETY IS INVOLVED.**

TABLE OF CONTENTS

1. SPECIFICATIONS	Page 1	6. MANUAL LIFT	Page 21
2. SERVICE INSTRUCTIONS AND ADJUSTMENTS	Page 4	7. HYDRAULIC LIFT (BARNES PUMP)	Page 29
2.1 Fuel		8. HYDRAULIC LIFT (ELECTRIC/HYDRAULIC PUMP) ...	Page 32
2.2 Lubrication		9. FUEL SYSTEM	Page 35
2.3 Engine Oil Check		9.1 Fuel Tank Removal	
2.4 Engine Oil Change		9.2 Fuel Tank Inspection	
2.5 Fasteners		9.3 Fuel Tank Installation	
2.6 Air Intake Screen		10. BRAKES	Page 35
2.7 Cooling System		10.1 Brake Removal	
2.8 Air Cleaner		10.2 Brake Repair and Inspection	
2.10 Transmission Oil		10.3 Brake Installation	
2.11 Brake		11. ELECTRICAL	Page 36
2.12 Forward and Reverse Clutch		11.1 Electrical Problem-Solving Chart	
2.13 PTO Clutch		11.2 Wiring Diagrams	
2.14 Steering		11.3 Ignition Switch	
2.15 Spark Plugs		11.4 Interlock Switches	
2.16 Hydraulic Service (Barnes Pump)		11.5 Fuse Holder	
2.17 Hydraulic Service (Elec./Hyd.)		11.6 Battery	
2.18 Battery		11.7 Ammeter	
3. TRANSMISSION	Page 13	11.8 Hourmeter	
3.1 Problem-Solving Chart		11.9 Solenoid Switch	
3.2 Transmission Disassembly		11.10 Regulator-Rectifier	
3.3 Gear and Shaft Removal		11.11 Relay	
3.4 PTO Shaft #10		11.12 Time Delay Module	
3.6 PTO Clutch #9		11.13 Electric/Hydraulic Pump Switch	
3.9 Differential #8		12. SPECIAL TOOLS	Page 42
3.12 Gear and Shaft Inspection		12.1 Tool Identification	
3.15 Transmission Assembly		12.2 Tool Illustrations	
3.16 Forward and Reverse Clutch			
4. ENGINE	Page 27		
4.1 Engine Adjustment			
4.2 Engine Removal			
4.3 Adaptor Plate			
4.4 Engine Installation			
5. WHEEL AND WHEEL BEARINGS	Page 28		
5.1 Bearing Removal			
5.2 Bearing Inspection			

SECTION 1

GENERAL SPECIFICATIONS

Model No. Description Name	987058 & 987059 14 HP Kohler Manual & Hydraulic Lift	987060 & 987061 16 HP Kohler Manual & Hydraulic Lift	987062 18 HP Kohler Hydraulic Lift
Length	82" (208.3 cm)	82" (208.3 cm)	82" (208.3 cm)
Width	41.5" (105.4 cm)	41.5" (105.4 cm)	43.2" (109.7 cm)
Height	51" (129.5 cm)	51" (129.5 cm)	51" (129.5 cm)
Weight	853 lbs.	858 lbs.	863 lbs.
Wheelbase			
Battery	12 Volt BCI Group 22F, 42 AMP Hr	12 Volt BCI Group 22F, 42 AMP Hr	12 Volt BCI Group 22F, 42 AMP Hr
Brakes	External Band Brake on transmission, individual rear wheel brakes optional	External Band Brake on transmission, individual rear wheel brakes optional	External Band Brake on transmission, individual rear wheel brakes optional
Steering	Rack & Pinion	Rack & Pinion	Rack & Pinion with heavy tie rods
Turning Radius	26.5" (67.3 cm)	26.5" (67.3 cm)	26.5" (67.3 cm)
Tire Sizes			
Front	16 x 6.5 - 8	16 x 6.5 - 8	16 x 7.5 - 8
Rear	23 x 8.5 - 12	23 x 8.5 - 12	23 x 10.5 - 12
Tire Pressure			
Front	14-18 PSI (97-124 kN/m ²)	14-18 PSI (97-124 kN/m ²)	14-18 PSI 97-124 kN/m ²)
Rear	16-14 PSI (69-97 kN/m ²)	16-14 PSI (69-97 kN/m ²)	16-14 PSI (69-97 kN/m ²)
Engine			
Type	Kohler	Kohler	Kohler
Model No.	CH14S	M18S	M18S
Spec No.	P-1810	PS-24633	PS-24590
HP	14	16	18
Engine Oil	See Engine Manual	See Engine Manual	See Engine Manual
Engine Oil Capacity	See Engine Manual	See Engine Manual	See Engine Manual
Fuel Specifications	See Engine Manual	See Engine Manual	See Engine Manual
Fuel Tank Capacity	5.3 Gals. (20 Liters)	5.3 Gals. (20 Liters)	5.3 Gals. (20 Liters)
Fuse	25 AMP	25 AMP	25 AMP
Transmission	6 Qt.	6 Qt.	6 Qt.
Oil Capacity	(5.7 Liters)	(5.7 Liters)	(5.7 Liters)
Transmission Type	API Service SC10W-30 Motor Oil	API Service SC10W-30 Motor Oil	API Service SC10W-30 Motor Oil
Manual Lift	58 Only	60 Only	Yes
Hydraulic Lift	59 Only	61 Only	ATF Dextron II
Hydraulic Type	ATF Dextron II	ATF Dextron II	ATF Dextron II
Hydraulic Capacity	1 Qt. (.9 Liter)	1 Qt. (.9 Liter)	1 Qt. (.9 Liter)

Model No. Description Name	987063 20 HP Kohler Hydraulic Lift	987064 & 987065 16 HP Briggs & Stratton Manual & Hydraulic Lift
Length	82" (208.3 cm)	82" (208.3 cm)
Width	43.2" (109.7 cm)	41.5" (105.4 cm)
Height	51" (129.5 cm)	51" (129.5 cm)
Weight	883 lbs.	860 lbs.
Wheelbase		
Battery	12 Volt BCI Group 22F, 42 AMP Hr	12 Volt BCI Group 22F, 42 AMP Hr
Brakes	External Band Brake on transmission, individual rear wheel brakes optional	External Band Brake on transmission, individual rear wheel brakes optional
Steering	Rack & Pinion with heavy tie rods	Rack & Pinion
Turning Radius	26.5" (67.3 cm)	26.5" (67.3 cm)
Tire Sizes		
Front	16 x 7.5 - 8	16 x 6.5 - 8
Rear	23 x 10.5 - 12	23 x 8.5 - 12
Tire Pressure		
Front	14-18 PSI (97-124 kN/m ²)	14-18 PSI (97-124 kN/m ²)
Rear	16-14 PSI (69-97 kN/m ²)	16-14 PSI (69-97 kN/m ²)
Engine		
Type	Kohler	Briggs & Stratton
Model No.	M20S	303447
Spec No.	PS49533	
HP	20	16
Engine Oil	See Engine Manual	See Engine Manual
Engine Oil Capacity	See Engine Manual	See Engine Manual
Fuel Specifications	See Engine Manual	See Engine Manual
Fuel Tank Capacity	5.3 Gals. (20 Liters)	5.3 Gals. (20 Liters)
Fuse	25 AMP	25 AMP
Transmission	6 Qt. (5.7 Liters)	6 Qt. (5.7 Liters)
Oil Capacity	API Service	API Service
Transmission Type	SC10W-30 Motor Oil	SC10W-30 Motor Oil
Manual Lift		64 Only
Hydraulic Lift	Yes	65 Only
Hydraulic Type	ATF Dextron II	ATF Dextron II
Hydraulic Capacity	1 Qt. (.9 Liter)	1 Qt. (.9 Liter)

GROUND SPEEDS (at 3600 RPM Engine Speed)

TRACTOR GROUND SPEEDS				
	FORWARD		REVERSE	
Gear	"LO" Range	"HI" Range	"LO" Range	"HI" Range
1	.5 mph (.8 km/hr)	2.5 mph (4.0 km/hr)	1.1 mph (1.8 km/hr)	Same
2	.8 mph (1.2 km/hr)	3.8 mph (6.1 km/hr)	1.7 mph (2.7 km/hr)	Same
3	1.1 mph (1.8 km/hr)	5.7 mph (9.2 km/hr)	2.5 mph (4.0 km/hr)	Same
4	1.7 mph (2.7 km/hr)	8.5 mph (13.7 km/hr)	3.8 mph (6.1 km/hr)	Same

Chart 1

BOLT TORQUE SPECIFICATIONS						
HARDWARE SIZE	GRADE 2		GRADE 5		GRADE 8	
	(ft.lbs)	(N.m)	(ft.lbs.)	(N.m)	(ft.lbs.)	(N.m)
1/4-20	5.5	7.48	8.0	10.88	12.	16.32
1/4-28	6.3	8.57	10.	13.60	14.	19.04
5/16-18	11.	14.96	17.	23.12	25.	34.00
5/16-24	12.	16.32	19.	25.84	25.	34.00
3/8-16	20.	27.20	30.	40.80	45.	61.20
3/8-24	23.	31.28	35.	47.60	50.	68.00
7/16-14	32.	43.53	50.	68.00	70.	95.20
7/16-20	36.	48.96	55.	74.80	80.	108.80
1/2-13	50.	68.00	75.	102.00	110.	149.60
1/2-20	55.	74.80	90.	122.40	120.	163.20
9/16-12	70.	95.20	110.	149.60	150.	204.00
9/16-18	80.	108.80	120.	163.20	170.	231.20
5/8-11	100.	136.00	150.	204.00	220.	299.20
5/8-18	110.	149.60	180.	244.80	240.	326.40
3/4-10	175.	238.00	260.	353.60	380.	516.80
3/4-16	200.	272.00	300.	408.00	420.	571.20
7/8-9	170.	231.20	430.	584.80	600	816.00
7/8-14	180.	244.80	470.	639.20	660.	897.60
1-8	250.	340.00	640.	870.40	900.	1224.00
1-12	270.	367.20	710.	965.60	1000.	1360.00

Chart 2



When replacing, tightening or reassembling any bolt(s) and/or nut(s), follow the bolt torque specifications chart for proper torque values.

SECTION 2

SERVICE INSTRUCTIONS

Chart 3 shows the recommended schedule for service that should be performed on a regular basis.

Service Performed	Time Intervals Between Service		
	Daily	25 hrs.	200 hrs.
Check Tire Pressure (Sec. 1)		X	
General Lubrication (Sec. 2.2)		X	
Check Engine Oil (Sec. 2.3)	X		
Check Fasteners (Sec. 2.5)			X
Check Air Intake Screen (Sec. 2.6)	X		
Check Cooling System (Sec. 2.7)		X	
Check Air Cleaner (Sec. 2.8)	X		
Check Transmission Oil (Sec. 2.10)			X
Check Hydraulic Fluid (Sec. 2.16)			X
Check Fluid Level and Clean Battery (Sec. 2.17)		X	

Chart 3

2.1 Filling the Fuel Tank



WARNING: Gasoline is very flammable. Follow safety instructions shown in Section 1, Operators Manual.

Gasoline is added as required. Use clean lead-free or regular-grade gasoline. To add gasoline:

1. Put the tractor in an open area.
2. Stop the engine and lock the brake.
3. Clean the fuel cap area.
4. Remove the fuel tank cap.
5. Fill the tank with gasoline. Use caution.

Do not overflow.

6. Reinstall fuel tank cap.
7. If gasoline is spilled, wipe it up.

2.2 General Lubrication

There are seven grease fittings to be greased at 25-hour intervals. Clean the fittings before attaching the grease gun. Use a lithium base grease. Add grease until it appears at the ends of the bearings. The locations of the seven fittings are:

1. On the Brake Pedal
2. On the front axle at each king pin.
3. On the front axle as shown in Figure 1.

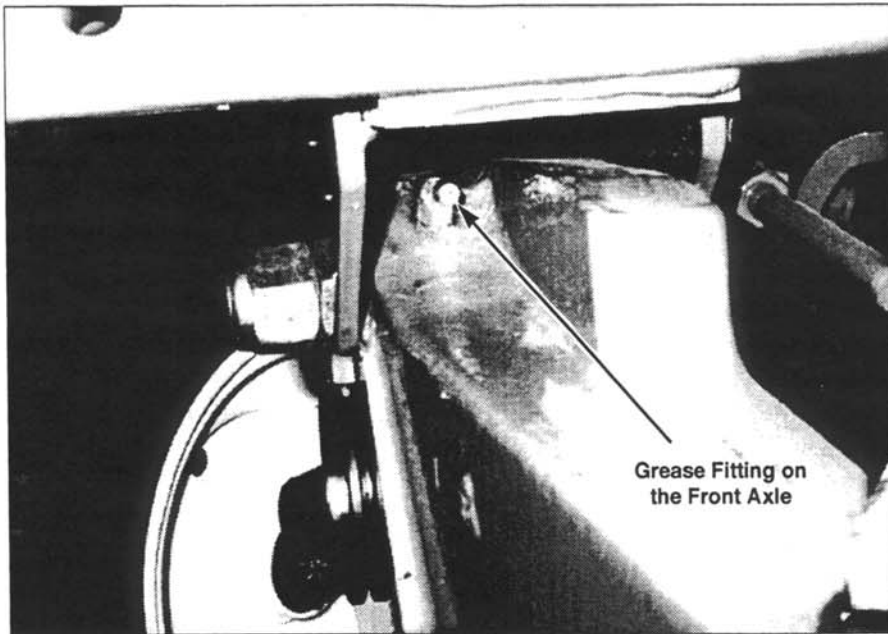

FIGURE 1

4. On the steering mechanism as shown in Figure 2.

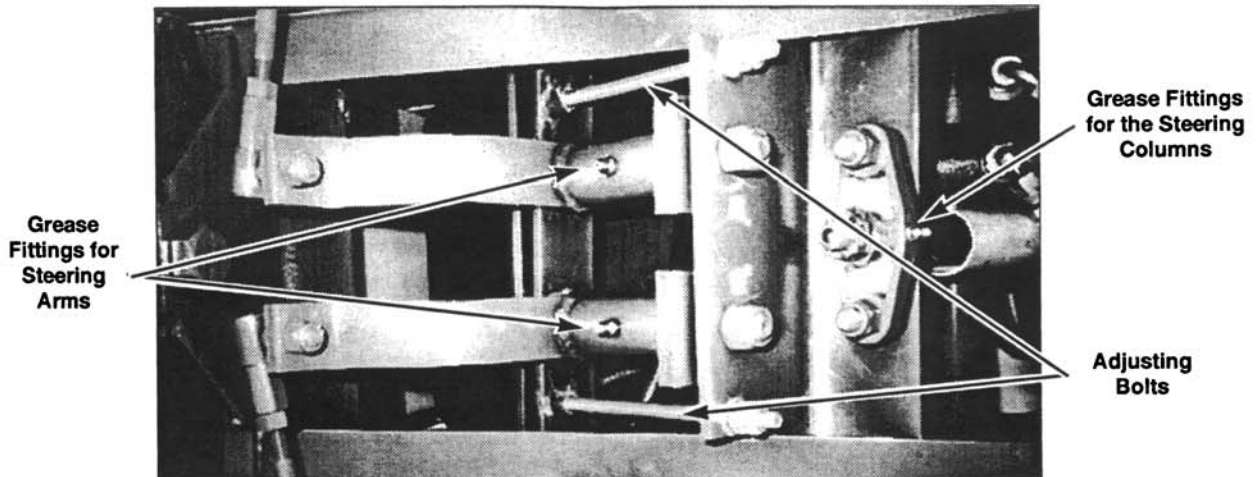

FIGURE 2

Apply motor oil to all pin connections, pivot points and areas where sliding occurs in the clutch, transmission, PTO, and lift control systems every 25 hours.

2.3 Checking the Engine Oil

Check the engine oil level daily. Never operate the engine with the oil level below the low mark in the dipstick. See your engine manual.

To check the oil level:

1. Park the tractor on a level area.
2. Clean around the dipstick to prevent dirt from entering the tube.
3. Remove the dipstick and wipe off the oil.
4. Put the dipstick back in place. Be sure it is all the way down.
5. Remove the dipstick again and note oil level.
6. Add oil, if needed. Do not overfill.
7. Repeat Step. 4.

2.4 Changing the Engine Oil

To change oil:

1. Read your engine manual for recommended change schedule and oil recommendation.
2. Move the tractor to a level area. Lock the brake.
3. If the engine is cold, let it run for 5 minutes.
4. When the engine is warm, stop it and raise the rear fender.



WARNING: Engine muffler and other parts are hot.

5. Clean the areas around the dipstick, drain plug, and oil filter (on the 18G and 20G models)
6. Remove the dipstick.

7. Put an open-top container under the drain plug.
8. Remove the drain plug.
9. Allow the engine to drain completely.
10. Remove Oil Filter (18G and 20G), and install new one. See Engine Manual for correct filter.
11. Clean and reinstall the drain plug.
12. Fill with new oil to the "FULL" mark on the dipstick.
13. Replace the dipstick. Lower the rear fender.
14. Start the engine and check for leakage at the drain plug. Tighten the plug if leakage occurs.

2.5 Checking the Fasteners

Check all fasteners periodically. Look for loose or missing fasteners any time looseness of parts, rattles, or excess noise and vibrations are noted. Make sure all bolts, screws, but, pins, snap rings, and cotter pins are in the correct position and replace any that are missing.

2.6 Checking the Air Intake Screen

Check the air intake screen on the engine each day. Remove any grass, dirt, or debris that may have accumulated on it. **THE AIR INTAKE SCREEN MUST BE KEPT CLEAN.**

2.7 Checking the Cooling System

Check the cooling system for signs of the collection of grass and debris in the engine cooling fins every 25 hours or more often when operated in dirty conditions. See your engine manual for instructions.

2.8 Checking the Air Cleaner

Check the air cleaner each day. See your engine manual for instructions.

2.9 Changing the Air Cleaner Element

Replace the air cleaner element at the correct intervals. See your engine manual for instructions.

2.10 Checking the Transmission Oil

Check the transmission oil level every 200 hours or twice a year, whichever comes first. If leakage is observed, check more frequently. The fill tube and check plug are shown in Figure 3 and 3A. To check the transmission oil level:

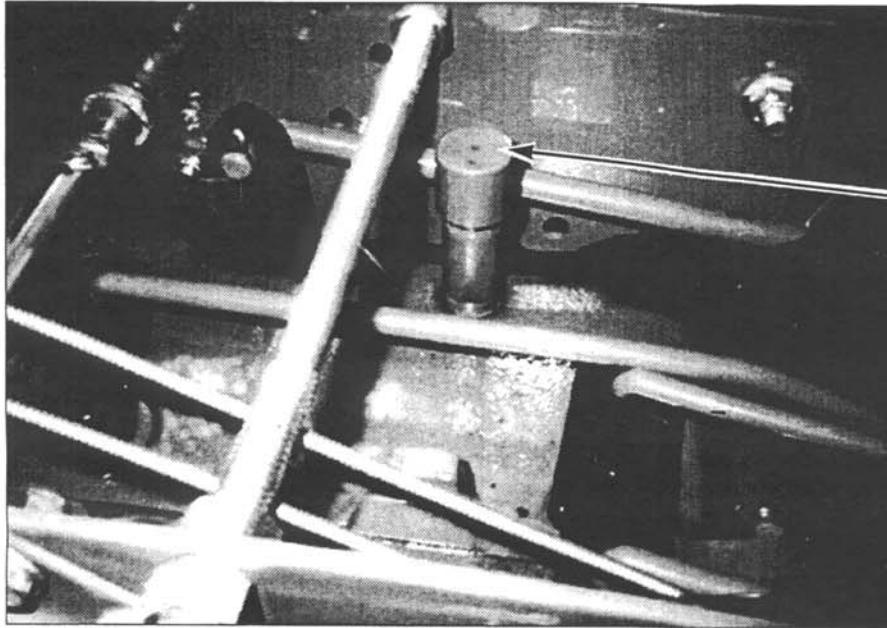

Fill Tube

FIGURE 3

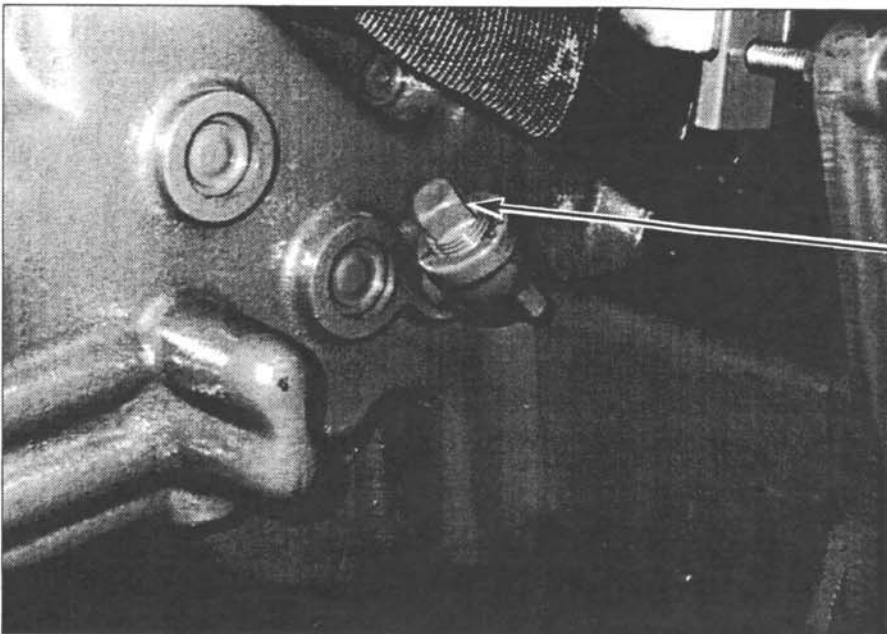

Check Plug

FIGURE 3A

1. Move the tractor to a level area. Stop the engine and lock the brake.

2. Raise the fender. Clean the check plug and remove it.

3. The oil level is correct when oil is at the bottom of the hole.

4. If the level is correct, reinstall and tighten the plug. If the level is low, add oil. See Section 1 for recommended lubricant specifications.

To add oil:

1. Remove the fill tube cap. Add oil until it reaches the check plug hole.

2. Reinstall and tighten the fill tube cap and check plug.

2.11 Servicing the Brake

Brake service is required if the brake does not stop and hold the tractor effectively. The brake should be effective enough to cause the rear wheels to slide if applied suddenly on a concrete or asphalt surface.



CAUTION: Replace the brake band when the lining is as thin as the ignition key. Replace the brake drum if it is visibly worn or rough.

To adjust the brake:

1. Stop the tractor on a level surface.

2. Stop the engine and block the wheels so the tractor cannot roll.

3. Loosen the jam nut and remove the clevis pin (at the brake band), See Figure 4.

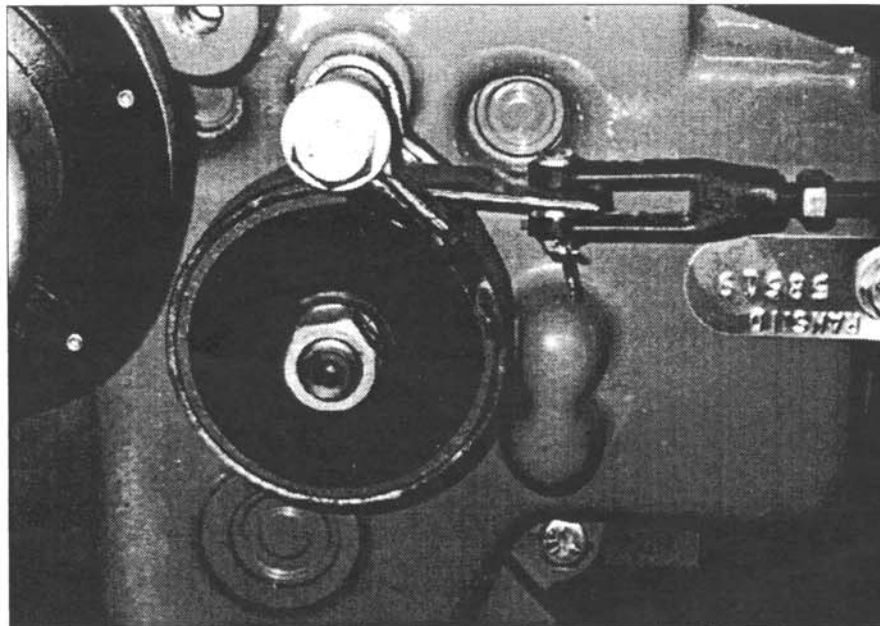

FIGURE 4

NOTE: DO NOT ADJUST THE BRAKE ROD ON THE LEFT HAND SIDE WHICH ATTACHES TO THE BRAKE PEDAL. THIS ROD IS FOR ADJUSTING THE DIRECTION CONTROL PEDAL ONLY.

4. Turn the clevis clockwise to tighten or counterclockwise to loosen as needed.

5. To check the adjustment, re-connect the clevis and brake band with the pin.

6. Push the direction control pedal all the way forward.

7. Push the brake pedal by hand while watching the motion of the brake band. The brake is correctly adjusted when the band becomes tight on the drum as the direction control pedal moves to "NEUTRAL." If the band is tight before the pedal moves to "NEUTRAL," the brake is too tight. If too tight or too loose, repeat Steps 4, 5, 6, and 7 until the correct adjustment is obtained.

8. Install the cotter pin in the clevis pin and tighten the jam nut.

9. Check the effectiveness of the brake while operating the tractor.

2.12 Servicing the Forward and Reverse Clutches

The forward and reverse clutches must be checked every 100 hours. If the lining has worn to a thickness of less than 0.150 inch (3.8mm), replace the lining. The forward clutch is on the right side of the transmission and the reverse clutch is on the left side of the transmission.

NOTE: Damage will occur if operated with a lining thickness of less than 0.150 inch (3.8mm).

Inspect and adjust the clutches as follows:

1. Stop the engine and place the direction control pedal in the "NEUTRAL" position.

2. Raise the rear fender.

3. Measure the clearance in the slot. The correct clearance is .030 inch (.76mm) to .060 inch (1.5mm) for the forward clutch and .010 inch (.25mm) to .030 inch (.76mm) for the reverse clutch. Figure 5.

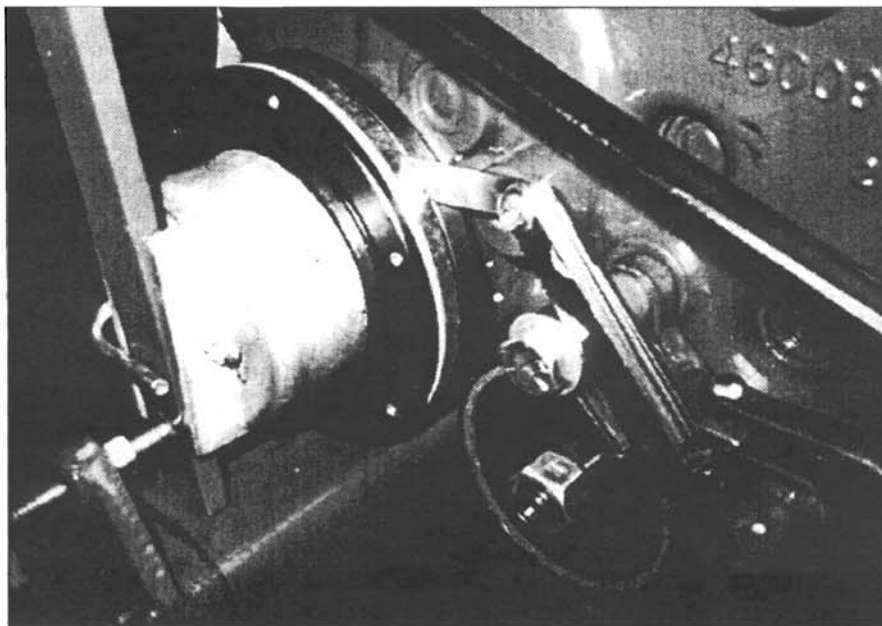

FIGURE 5

4. Adjust the bolts which go through the flange on the axle bearing retainer so that the forward-reverse clutch springs are straight up and down when the clutches have zero clearance. Lock the bolt in place with the jam nut. Loosen the jam nut which holds the slide rod bushing in place. Adjust the bushing on the slide rod until the clearance is correct. Lock the bushing in place with the jam nut.

5. Lubricate the clutch and forward/reverse slide rod once each season. Remove the clutch and apply a film of multi-purpose grease to the splined clutch shaft. While the clutch is off, check the lining wear. If the lining has worn near the rivet heads, replace the lining. Re-adjust the clutch as described above.

2.13 Servicing the PTO Clutch

The PTO clutch should be adjusted whenever there is less than .5 inches of free travel in the clutch lever when it is in the "ON" position. See Figure 6 to see where this free travel is measured. The free travel should be between .5 inch and 1.0 inch. To adjust:

1. Stop the engine and lock the brake.
2. Loosen the bolts holding the switch bracket and push the bracket down.
3. Raise the rear fender.
4. Push the PTO lever to "ON."
5. Disconnect the PTO control from the transmission lever.
6. Turn the control rod to change the free travel. Each turn will change it by about .25 inch. Turn clockwise to increase and counterclockwise to decrease the free travel. See Figure 6.

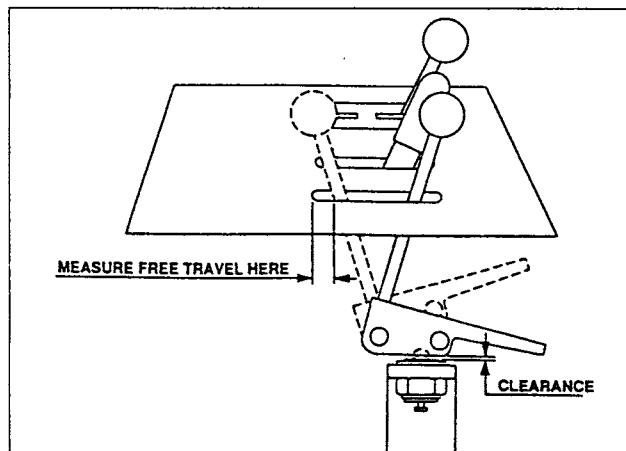

FIGURE 6

7. Re-connect the control rod to the transmission lever. Check for correct free travel. Repeat Steps 4, 5, and 6 if necessary.
8. Put the PTO control in the "Off" position.
9. Move the switch bracket up until the switch closes (makes a circuit). Tighten the switch bracket hardware.



CAUTION: Make sure that the PTO control assembly does not rest on the switch body.

2.14 Servicing the Steering System

Adjustment of the steering gear is usually needed whenever there is more than 2 inches of free play in the steering wheel. To adjust the steering gear:

1. Loosen the lock nuts on both adjusting bolts. See Figure 2.
2. Turn the steering wheel to the right as far as it will go.
3. Turn the adjusting nut on the left side adjusting bolt clockwise with your fingers until it is tight. Then back the nut off one fourth turn.
4. Tighten the lock nut against the adjusting nut being careful not to move the adjusting nut.
5. Turn the steering wheel to the left as far as it will go.
6. Repeat Steps 4 and 5 for the right side adjusting nut.
7. Check for tightness or backlash in the steering gear through the full range of the steering wheel rotation. There should be no noticeable tightness or backlash in the rack and pinion mesh. If there is, repeat Steps 3 and 7 as required.

Upon completion of the steering gear adjustment, re-check the steering wheel free play. If the free play is still excessive, look for loose steering arms on the king pins, loose or worn ball joints, or other signs of wear. Tighten or replace as required.

Adjust the front wheel toe-in as follows:

1. Rotate the steering wheel until the two

steering arm weldments are parallel to the frame side.

2. On the 14 H.P. and 16 H.P. engine units, loosen the jam nuts on the tie rods and disconnect the outside ball joint. Rotate the front tires by hand so that the distance between the front centerline of the tire is 1/8" to 1/2" less than the distance between the rear centerline. Adjust the tie rods so that the ball joint can be connected to the tie rod arm without moving the tire and so that the tie rods are the same length. Tighten the jam nuts.

3. On 18 H.P. and 20 H.P. engine units, loosen the jam nuts on the tie rods and rotate the tire rod tube so that the front centerline of the tire is 1/8" to 1/2" closer than the rear centerline and so that the tie rods are the same length. Tighten the jam nuts.

2.15 Servicing the Spark Plug(s)

To clean or change a spark plug:

1. Stop the engine, lock the brake, and raise the seat pan weldment.
2. See your engine manual for further instructions.

2.16 Hydraulic Lift Service and Fluid Check (Barness Pump)

Check the hydraulic fluid level every 200 hours or when the hydraulic lift will not raise the attachment or leaks are observed. The filter is under the hood. See Figure 7.

To check the hydraulic fluid level:

1. Put the hydraulic lift control in the "FLOAT" (full forward) position.
2. Clean the area around filter/reservoir.
3. Remove the filter/reservoir.

NOTE: When the filter is removed, some oil will run out because of the low pressure valve in the filter. Oil spillage will be minimized if the filter is removed after the tractor has not been operated for one-half hour.

4. The correct hydraulic fluid level is one inch from the top of the filter. Add Dextron II or Dextron III ATF to maintain this level.

The filter/reservoir should be replaced when:

- A. The tractor has been used one year commercially.
- B. The tractor has been used two years by a consumer.
- C. The hydraulic system has been repaired.

To install a new filter/reservoir:

1. Fill a new filter to one inch from the top (observe the threaded hole).
2. Let the filter set for 15 minutes. Refill the filter to the correct level.



FIGURE 7

3. Install the filter.

4. If the hydraulic system has been repaired or leaks fluid:

- a. Operate the lift.
- b. Shut off the tractor.
- c. Put the hydraulic lift control in the "FLOAT" position.
- d. Remove the filter/reservoir and fill to one inch below the top.
- e. Replace the filter/reservoir.

2.17 Units with electric hydraulic lift system

Service hydraulic reservoir as needed. Service reservoir to high-level mark on reservoir to allow room for expansion of hydraulic fluid. See Figure 8.

To Service Reservoir:

1. Clean the area around the reservoir cap.
2. Remove cap.
3. Service with clean, fresh Dextron II or Dextron III ATF.
4. Install cap.

2.18 Checking the Battery

Check the battery fluid every 25 hours. On tractors with low water loss batteries, check the fluid level once a season if the cap can be removed. Use caution and wear eye protection when checking the battery. To check the battery:

1. Clean the top of the battery.
2. Lift the filler caps.
3. If the fluid level is below the split rings in the filler tube, add distilled water. Do not fill above the split ring. Do not use a metal funnel.
4. Reinstall the filler caps. Push them all the way down.

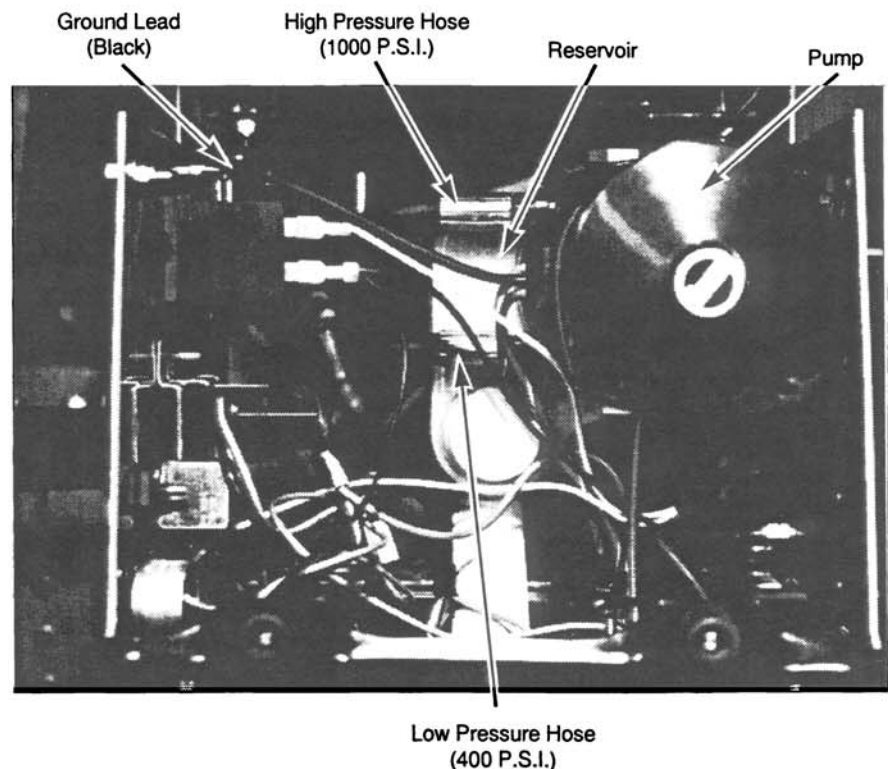

FIGURE 8

SECTION 3

TRANSMISSION

3.1 Problem-Solving Chart:

PROBLEM	POSSIBLE CAUSE
1. Tractor will not move.	Axle key sheared Clutch - lining worn - linkage broken Shifting Fork dowel pin sheared in slide rod Broken axle Crankshaft key sheared Differential failure (check to see if brake drum turns)
2. Tractor will move only in reverse	Adjustment of range linkage Hi-lo range in neutral Forward clutch - lining worn or linkage broken
3. Tractor will move only in forward	Reverse clutch - lining worn or linkage broken
4. Attachment does not operate	PTO linkage out of adjustment PTO clutch lining worn out Crankshaft key sheared
5. Attachment will not stop	PTO clutch stuck PTO linkage out of adjustment
6. Difficult or impossible to shift Hi/Low Range	Control linkage Roll pin in shifter arm sheared Broken shifter fork Burred hi-lo shifting gear
7. Gear shift lever will not go in 1, 3 position or 4, 2 position	1, 3 or 4,2 gears not in neutral, Gears not aligned, rock tractor, or momentarily engaged clutch, #6 shaft bent
8. #6 shaft turns but not wheels	Shafts 1 thru 6 are likely okay. Problem is probably in #7 (final pinion) or #8 (differential). Possible broken axle.

3.2 Transmission Disassembly

NOTE: It is not necessary to remove the engine unless the PTO clutch assembly (#9 Shaft) is to be removed. But for the purpose of this manual, the engine was removed for the total tear-down of the transmission.

For Engine Removal and Installation see Section 4.

1. Remove rear deck
2. Disconnect the battery ground cable.
3. Drain transmission fluid.
4. Turn off fuel at fuel tank and disconnect fuel line at engine.
5. Jack tractor to lift rear wheels. (Do not use engine

as a jack point.) Block front wheels. Position jack stands at the rear of the frame. It may be convenient to disconnect the brake linkage to position the jack stands.

6. Remove the right tire assembly. Loosen the 3/4" lock nut, use gear puller to loosen hub. Remove lock nut, washer, hub and key. Repeat on left side if the differential (#8 shaft assembly) is to be removed. See Figure 9.

7. Disconnect the Fwd/Rev neutral switch.

8. Remove forward and reverse clutch springs. See Figure 10.

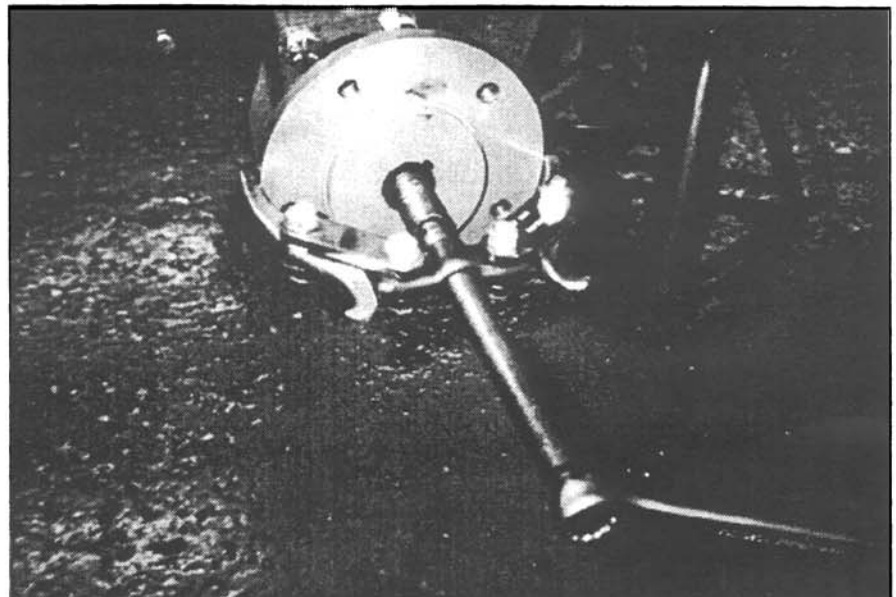

FIGURE 9

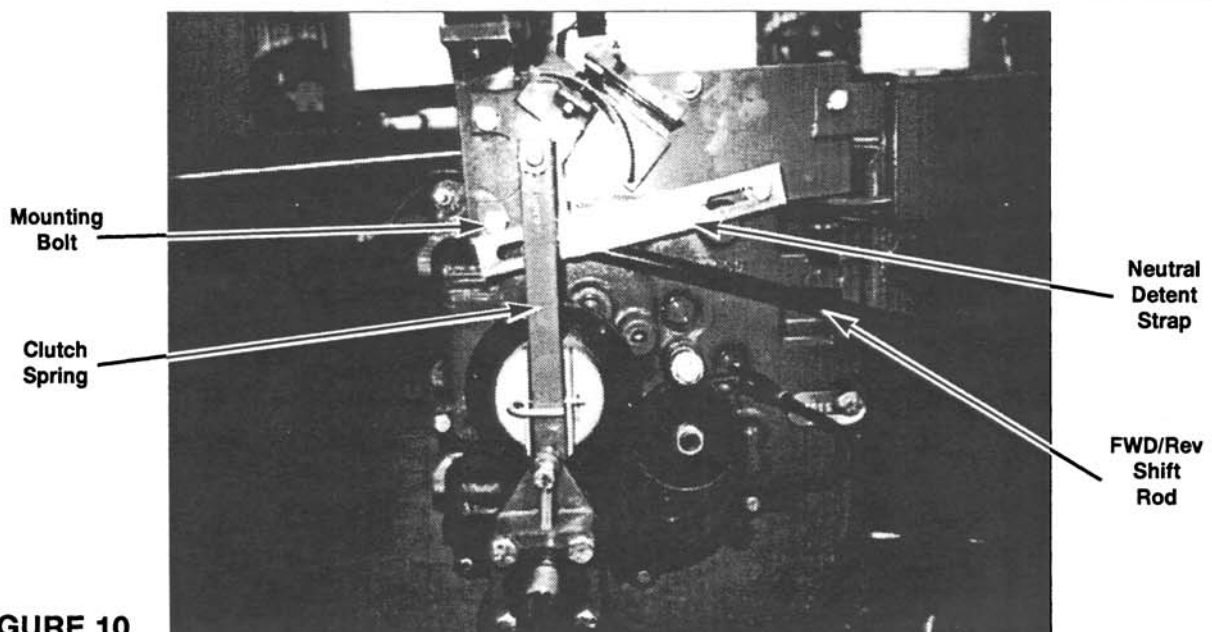

FIGURE 10

9. Disconnect the Fwd/Rev shifter rod from the Fwd/Rev clutch roll arm. Disconnect the neutral detent strap and neutral detent spring. See Figure 10.

10. Remove the left and right side, lower forward-reverse mounting plate bolts. See Figure 10.

11. Swing both plates up and out of the way. See Figure 11.

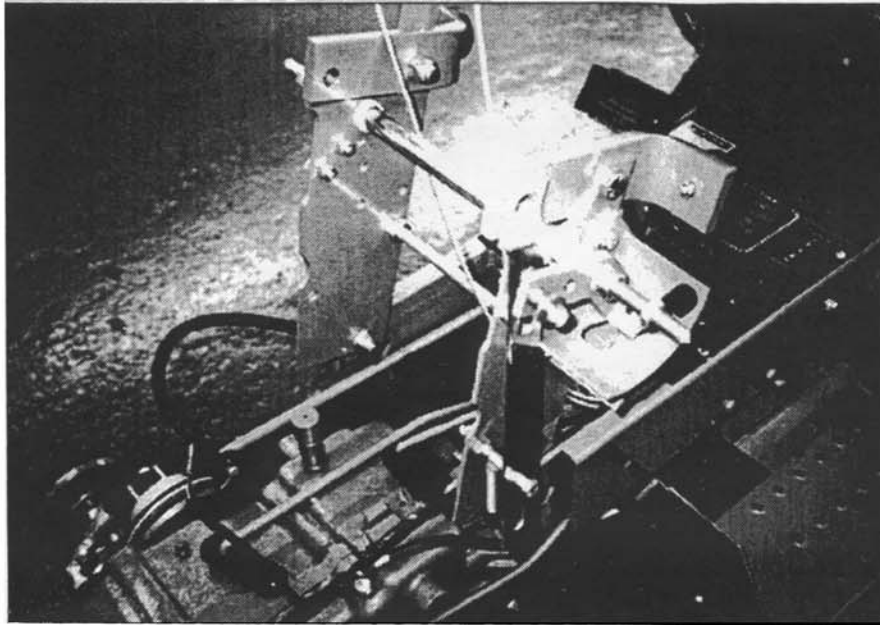

FIGURE 11

12. Disconnect ground wires from transmission.

13. Clean the right axle and remove the axle bearing retainer.

14. Remove the forward clutch assembly. Remove the spring, flat washer, and retaining ring from the forward clutch. (#1 Shaft Assembly.) Repeat on the other side if the reverse shaft (#2 Shaft Assembly) is to be removed.

15. Remove the brake band and brake drum.

16. Remove the E-Ring on the PTO yoke shaft. Remove all visible paint and debris from PTO yoke shaft.

17. Put the gear shift lever in the "NEUTRAL" position. The PTO control in the "ON" position, and the Hi-Lo lever in the "LO" position.

18. Remove the cover bolts.

19. Place a clean cloth or box under the transmission to catch any parts that might fall out.

20. Clean paint and debris off the exposed part of #1, #6, and #8 shafts. Tap the cover with a soft hammer and pry off with two screwdrivers or pry bars. Tap #1, #6, and #8 shafts, and the PTO yoke shaft as the cover is worked off. See Figure 12.

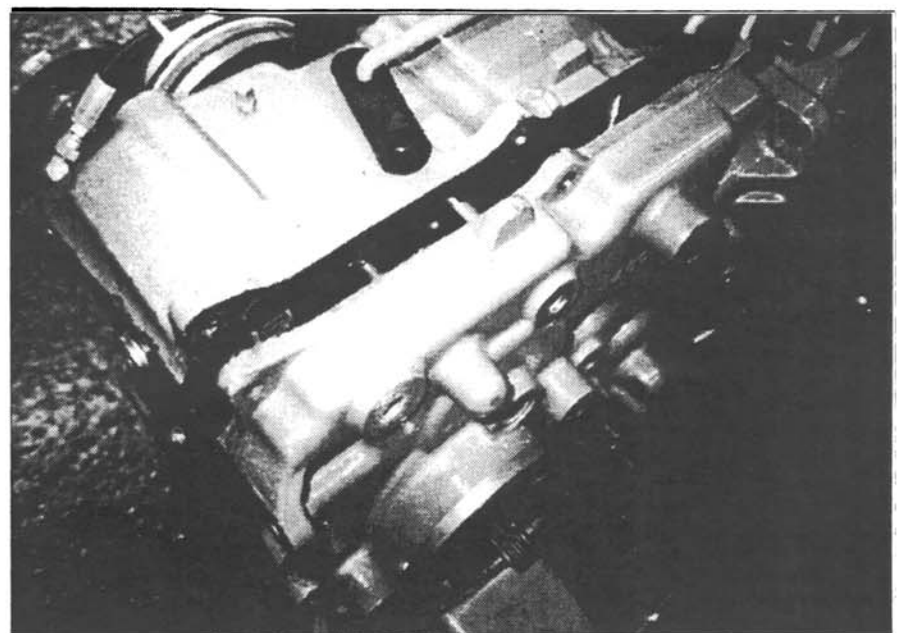

FIGURE 12

3.3 Gear and Shaft Removal

1. Remove idler gear assembly and races from #2 shaft assembly. See Figure 13.
2. Remove #7 shaft assembly.

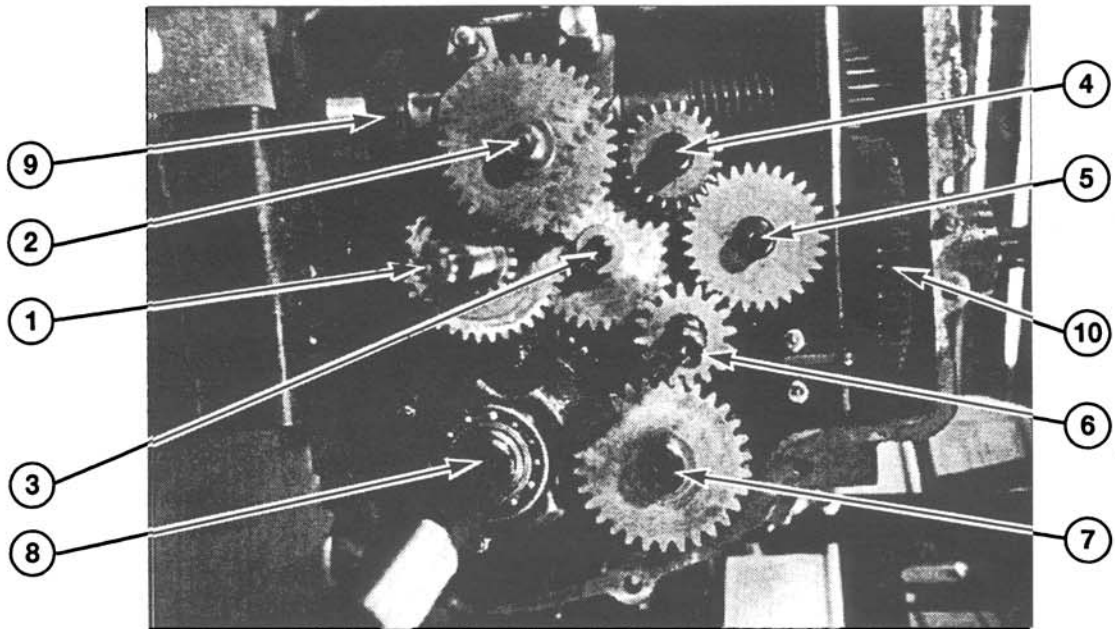

FIGURE 13

3. Remove #5 shaft assembly.
4. Remove #4 shaft assembly.
5. Remove the hi-lo detent spring and ball. A magnet can be used to lift the ball out of the case. See Figure 14.

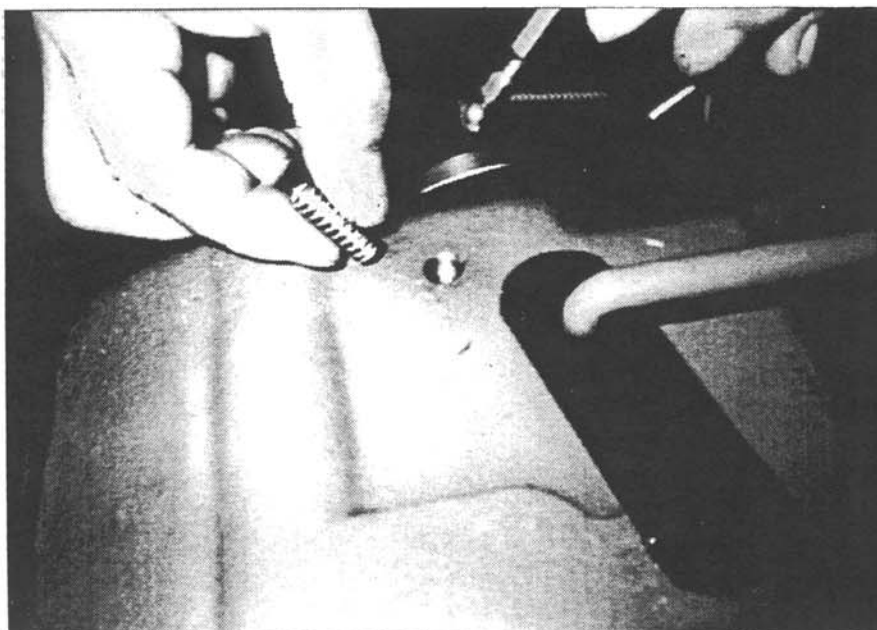

FIGURE 14

6. Remove #1 shaft assembly along with hi-lo shift fork.

7. Remove #3 shaft assembly.

8. Remove #6 shaft assembly.

9. Remove #8 shaft assembly.
See Figure 15.

10. Remove #2 shaft. Slide races towards reverse drive to clear #9 shaft.

11. Removal of #9 shaft assembly (PTO Clutch):

A. Remove engine. See Section 4.

B. Disconnect PTO lever.

C. Remove E-Ring, PTO lever and key.

D. Pull yoke shaft out and remove PTO yoke. (Note orientation of yoke.)
See Figure 15.

E. Remove front PTO cap.

F. Remove retaining ring on rear clutch cup.

G. Slide assembly forward. Swing rear outward and pull out of case.

See Figure #16.

See Figure #16.

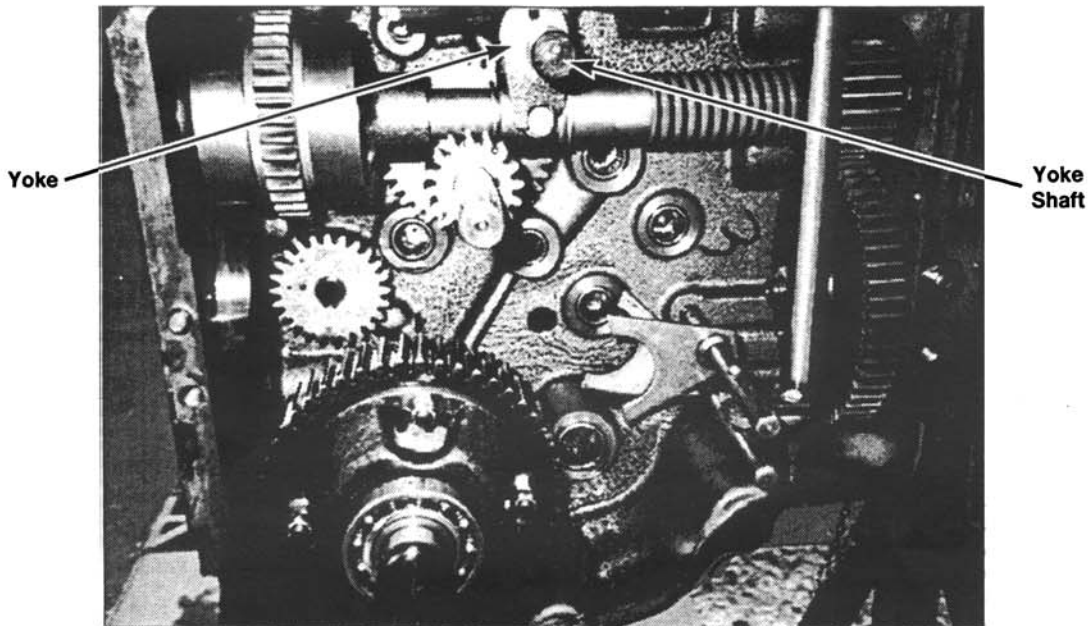

FIGURE 15

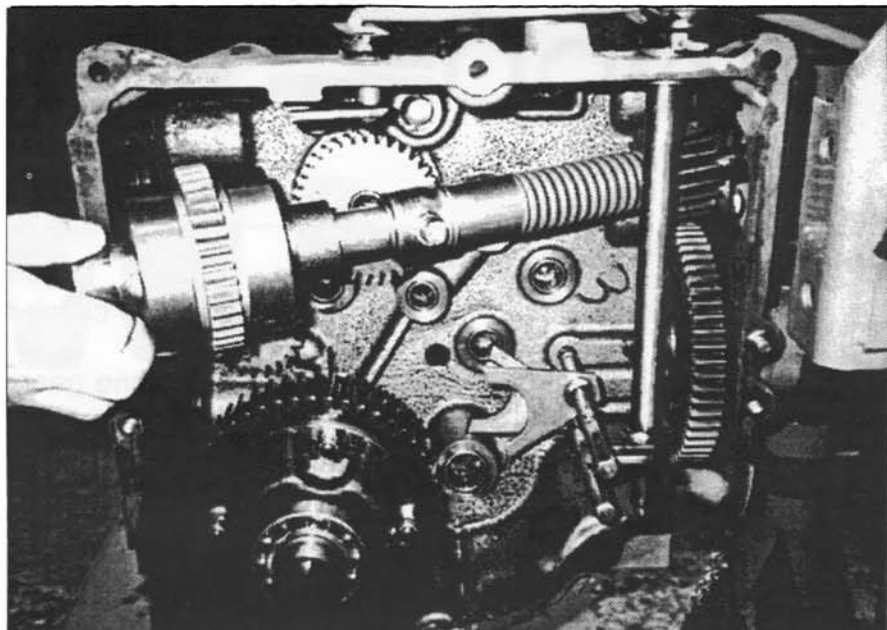

FIGURE 16

12. Removal of #10 shaft assembly

(PTO shaft):

- A. Put the male universal shaft on the PTO shaft. Rotate the U-Joint to 90° and rotate against the tractor frame. (Right side)
- B. Use a 15/16 wrench to remove the lock nut on the end of the shaft.
- C. Pull shaft forward out of the transmission case.
- D. Drive out seal and remove bearing.
- E. Inspect bearing races and remove if worn or damaged. Use a bearing puller to remove the races.
- F. Use the snap ring clamp and snap ring pliers to remove the snap ring. See Section 10.

2. Put snap ring in the groove and press races from either side using a driver. See Section 10.

3. Put cone in front race and press seal into position.

4. Put cone spacer, bearing cone, spacer, and gear in position and slide shaft into place.

5. Put a hardened washer (33845) next to the gear and secure assembly with "new" lock nut. Use the U-joint assembly to hold the shaft.

3.4 Inspection and Repair of #10 Shaft (PTO Shaft). See Figure 17

3.6 Disassembly of #9 Shaft Assembly (PTO Clutch)

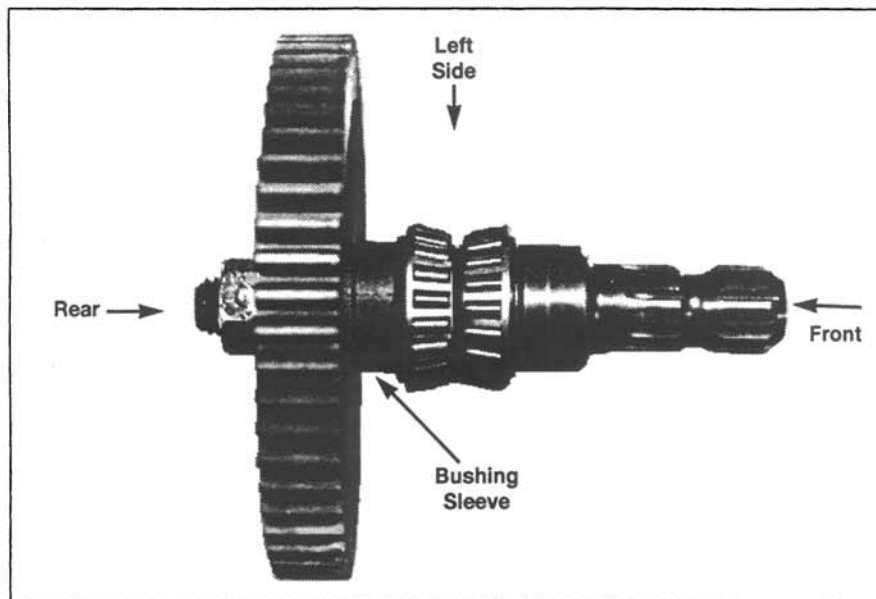

FIGURE 17 - #10 Shaft (PTO Output)



CAUTION: PTO spring is under high pressure. Use extreme caution when disassembling.

1. Inspect all parts for wear and damage.
2. Replace all worn or damaged parts.

3.5 Assembly of #10 Shaft (PTO Shaft)

1. If bearings are to be replaced, secure a complete new bearing set as the parts are matched.

1. Use a bearing puller with long legs in a push-puller to compress the spring.

2. Compress spring until the clutch cup clears the retaining ring.

3. Remove the retaining ring.

4. Remove the rear clutch cup and key.

5. Remove the cone gear, front clutch cup, and key.

6. Release the spring, slide remaining parts off the shaft while noting their position.

3.7 Inspect and Repair of #9 Shaft (PTO Clutch).

See Figure 18 & 18A

1. Inspect all parts for damage and wear.
2. Replace all parts damaged or worn. The retaining rings should be replaced.

3.8 Assembly of #9 Shaft (PTO Clutch)

1. Reverse the disassembly procedure given in 3.6. Be sure the retaining ring is in place before releasing the spring pressure. Use plenty of 30-W engine oil on clutch parts; failure to do so will cause the PTO clutch to stick in the "on" position.

3.9 Disassembly of #8 Shaft (Differential)

1. Remove the four bolts holding the assembly.
2. Use a soft hammer to loosen the assembly and pull apart.
3. Remove the axle retaining rings.
4. Remove bearings from the end cap with a soft hammer.

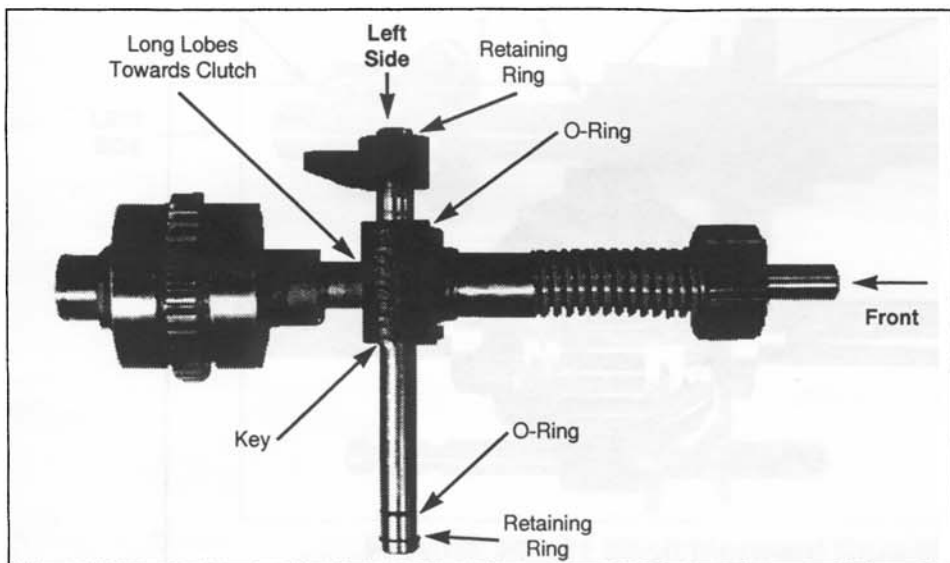

FIGURE 18 - #9 (PTO)

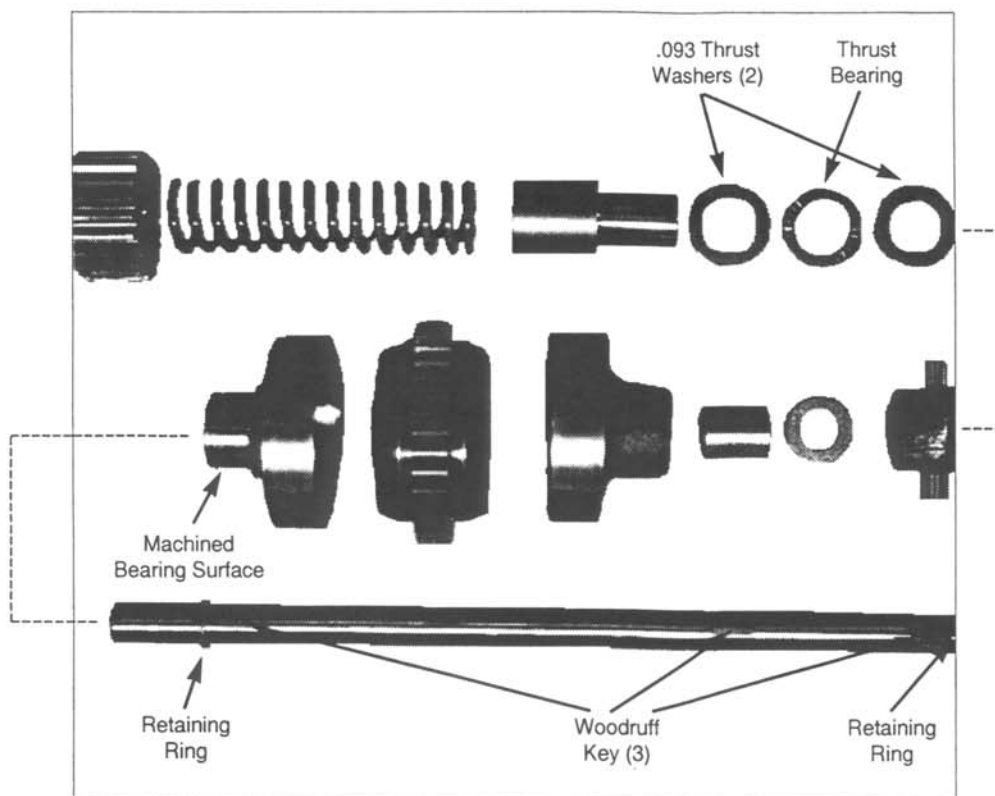

FIGURE 18A - #9 (PTO)

3.10 Inspection and Repair of #8 (Differential-Axle).

See Figure 18

1. Inspect all parts for damage and wear.
2. Replace any parts worn or damaged.

3.11 Assembly of #8 (Differential-Axle)

1. Reverse the disassembly procedure.
2. Use nut retaining compound on the four bolts and tighten to a torque of 25 ft-lb.

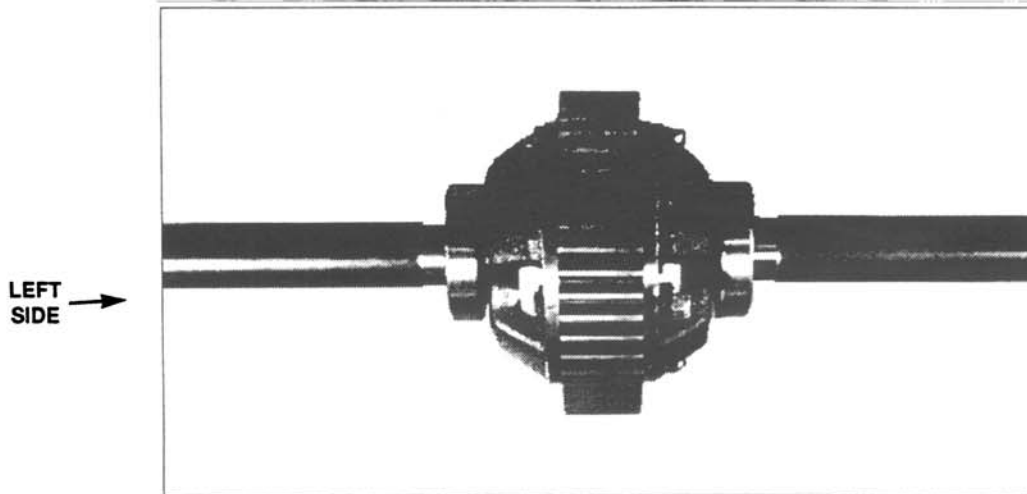

FIGURE 19 - #8 Shaft (Differential)

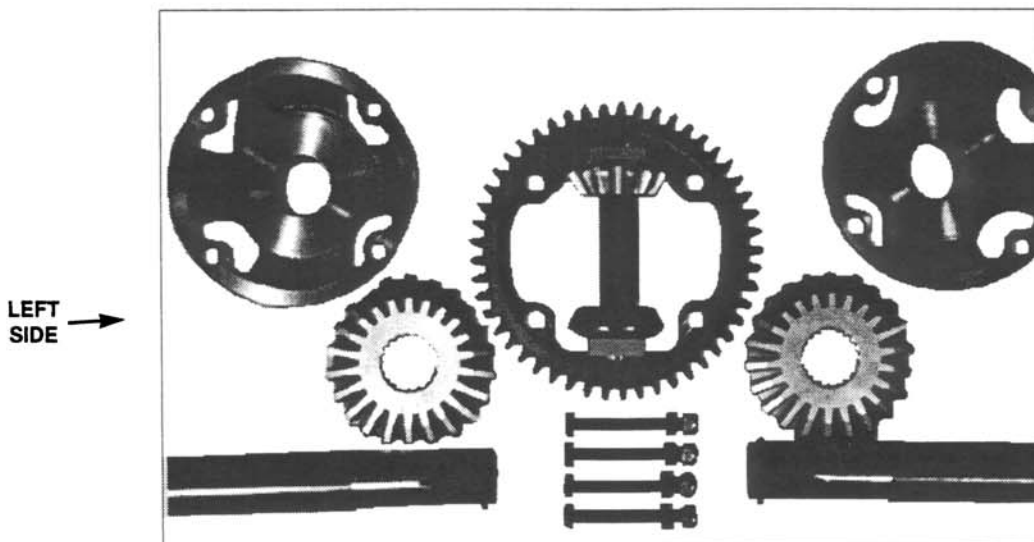

FIGURE 19A - #8 Shaft (Differential)

3.12 Gear and Shaft Inspection and Repair

1. Inspect all parts for wear and damage.

2. Replace any part worn or damaged. If a bearing or thrust race is damaged, replace the bearing and both thrust races. See Figures 20, 21, 22, 23, 24, 25 and 26.

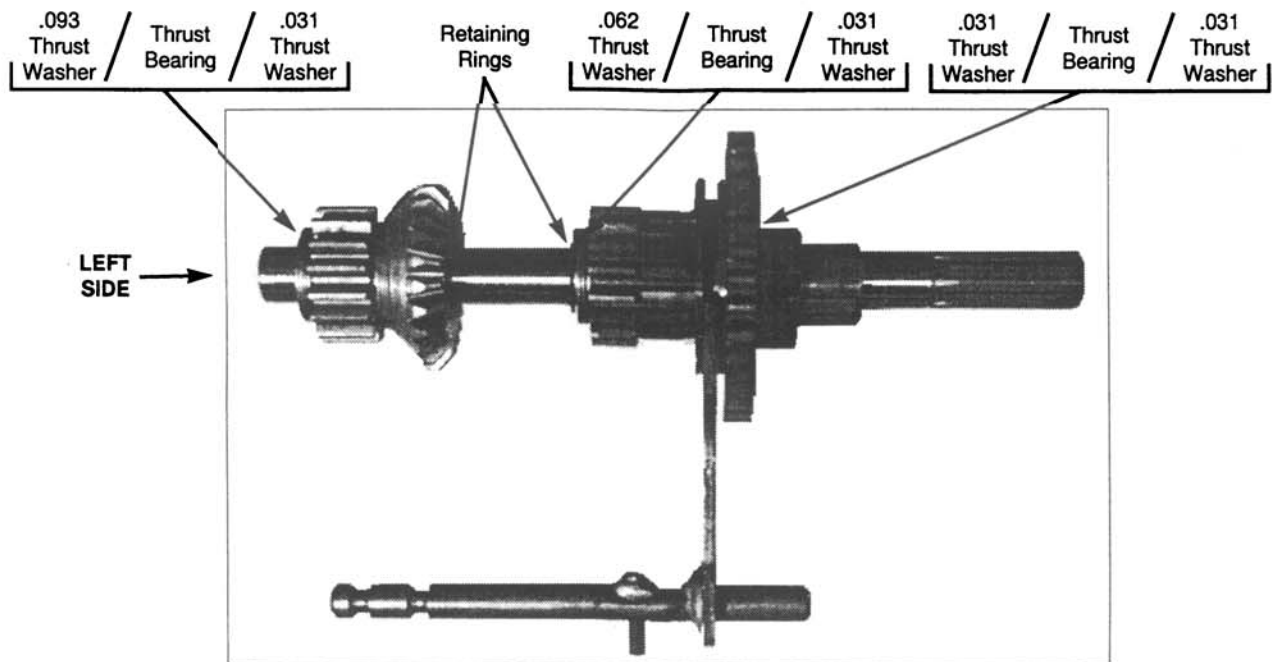

FIGURE 20 - #1 Shaft (Forward Clutch)

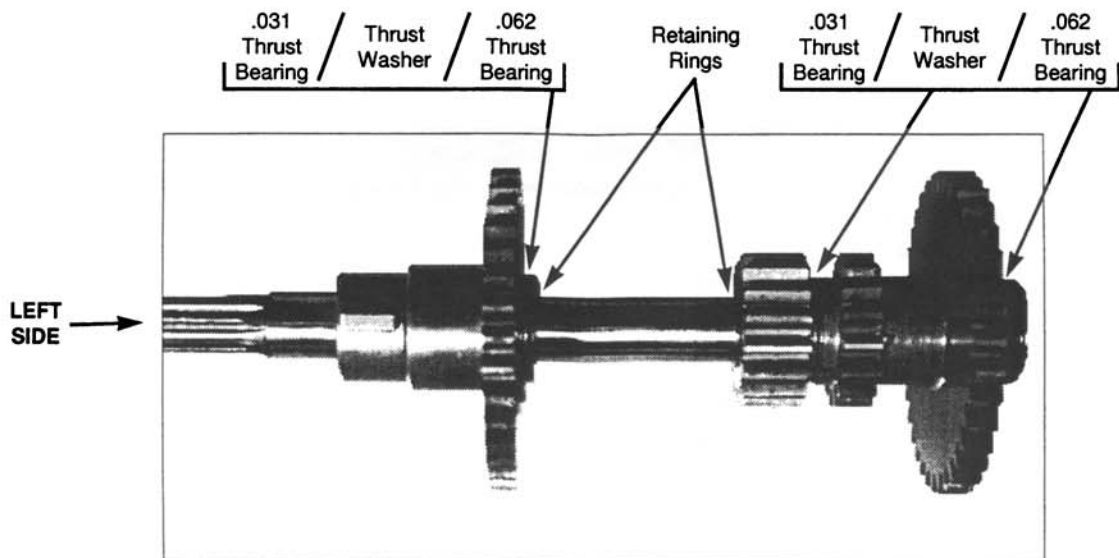

FIGURE 21 - #2 Shaft (Reverse)

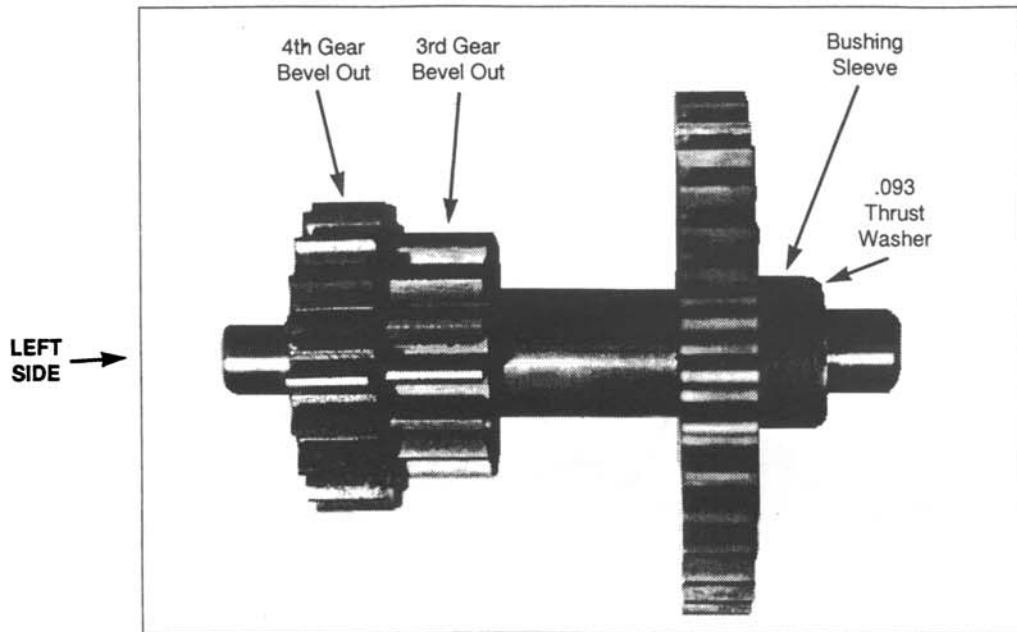

FIGURE 22 - #3 Shaft (3rd & 4th Gear)

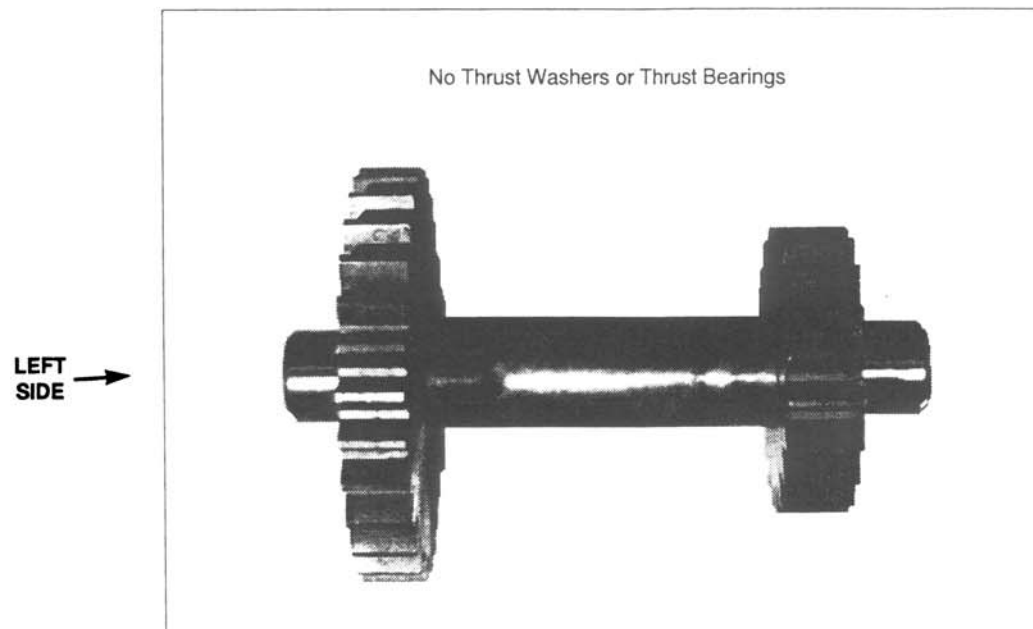

FIGURE 23 - #4 Shaft (Idler)

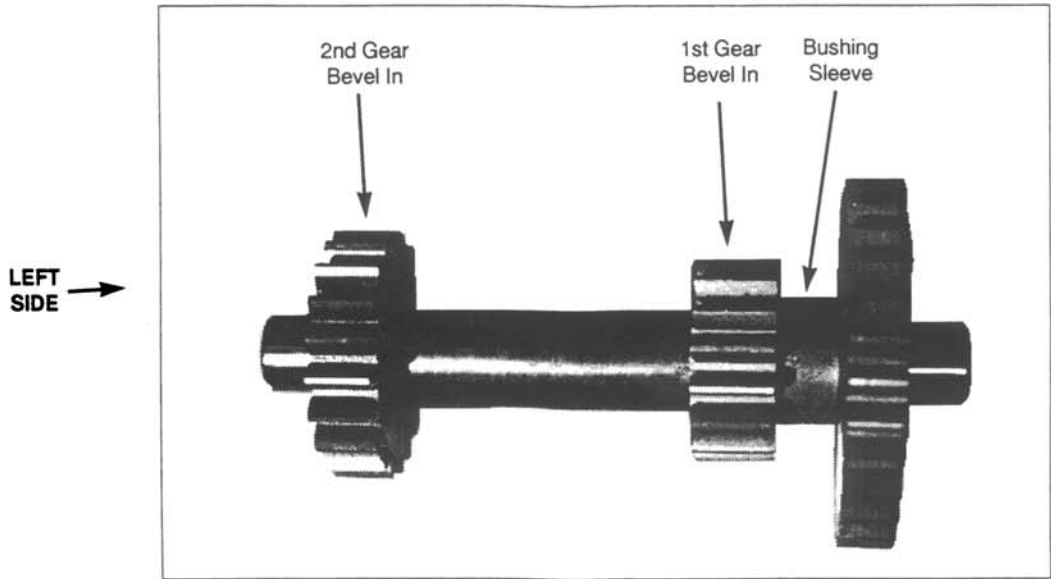

FIGURE 24 - #5 Shaft (1st & 2nd Gear)

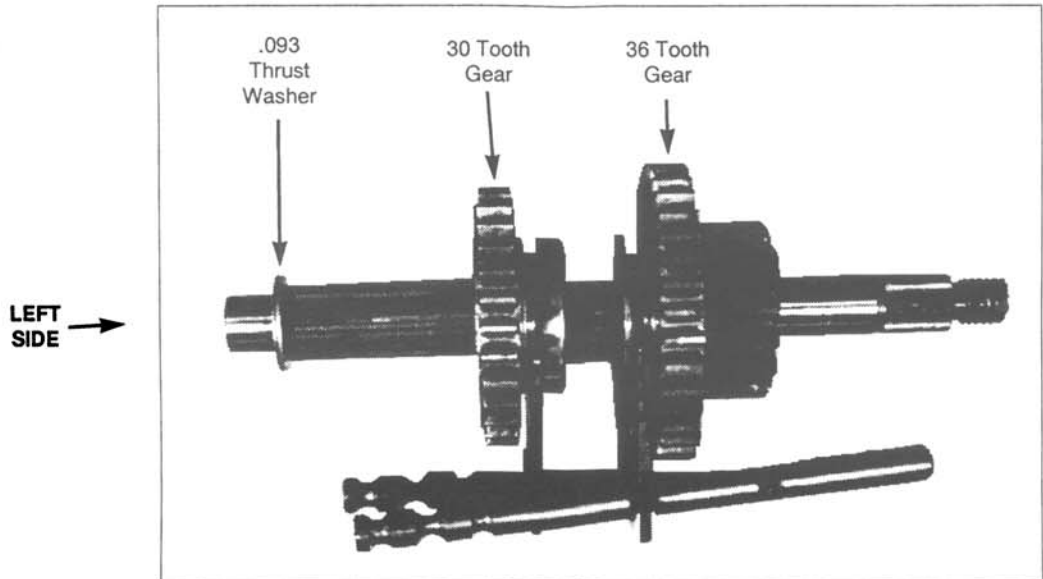

FIGURE 25 - #6 Shaft (Brake-Sliding Gear)

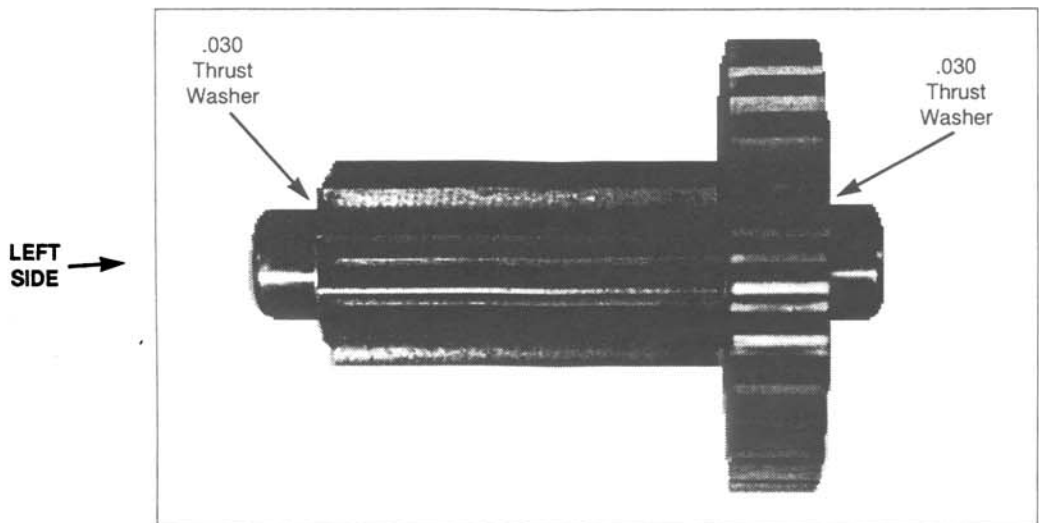

FIGURE 26 - #7 Shaft (Pinion-Final Drive)

3.13 Check the seals for wear and damage in the forward/reverse clutch hubs, #6 shaft seal, axle seals and PTO cap. Replace as needed.

3.14 Gear and Shaft Installation

1. Put the key in the hub of the gear-bearing assembly which goes on the right end of #1 shaft. Put grease on the hub and slide the gear-bearing assembly into the clutch hub (forward clutch) in the cover. (See Figure 27.)

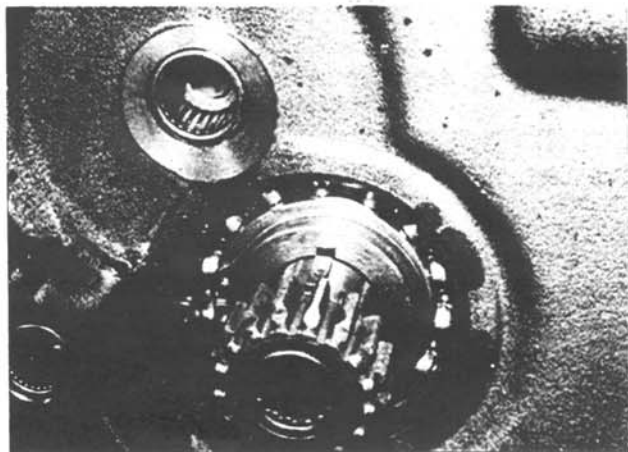

FIGURE 27

2. Put the key in the hub of the reverse gear and bearing assembly which goes on the left end of #2 shaft. Put grease on the hub and slide the reverse gear and bearing assembly into the clutch hub (reverse).

3. Position the controls
- A. PTO to "ON"
 - B. Hi-lo to "LO"
 - C. Gear to "NEUTRAL"
 - D. Fwd-rev to "NEUTRAL"

4. Installation of #9 shaft assembly (PTO clutch)
- A. Put the front of the assembly through the front hole of the case. Move rearward into the bearing. Tap the bearing with a soft hammer until the shaft is in place.
 - B. Install the square retaining ring.
 - C. Slide the front PTO cap coated with gasket eliminator in place and secure with two bolts.

- D. At the rear, rotate the bearing snap ring gap to the top position.
- E. Put O-rings and a key in the PTO yoke shaft. Coat the O-rings with grease.
- F. Slide the PTO yoke in position over the key and into the case. Note orientation of yoke — heavy side to rear. See Figure 14.
- G. Install woodruff key, PTO Lever (flat side inward) and E-ring.
- H. Connect PTO lever to the PTO rod with a washer and cotter pin.

5. Install the shaft assemblies in the following order:

- A. #6 shaft. Install interlock pin, detent balls, detent springs and shift forks if removed. If removed, replace the shifter weldments and associated parts first.
- B. #8 shaft (differential).
- C. #1 shaft with 2-speed shift rail, detent ball, detent spring, and plug. Reconnect 2-speed linkage.
- D. #3 shaft.
- E. #2 shaft. Put the bearing and bearing race near the end of the shaft so as to clear the PTO assembly.
- F. #4 shaft.
- G. #5 shaft.
- H. #7 shaft.

3.15 Transmission Assembly

1. Coat the case and cover with gasket eliminator and place with new gasket on the case. Slide the cover in place by tapping with a soft hammer.

2. Start all of the cover bolts, then tighten the cover bolts. Install the two engine mounting bolts, and tighten all four (if engine wasn't removed).

3. Install the E-ring on the PTO yoke shaft.

4. Install the brake drum and brake band.

5. Put a seal protector coated with oil on the axle in the axle bearing retainer assembly. Coat a new gasket with grease and stick

it to the axle bearing retainer. Slide the assembly in place on the axle and install the four bolts. Remove the seal protector. Repeat on the other side if removed.

6. Put the snap rings on #1 and #2 shafts and coat the splines with grease. Put the flat washer, spring and clutch assembly(s) in place.

7. Reconnect the ground wires to the transmission case.

8. Swing the forward-reverse mounting plates back down into place. Install bolts and tighten, retight front mounting bolts.

9. Reconnect the direction control lever, neutral detent spring and detent stop.

10. Install forward and reverse clutch springs.

11. Reconnect the forward-reverse neutral switch.

12. Coat the axle(s) with grease, put the key(s) in place and put the wheel hub(s) on the axle(s). Install washer, and lock nut.

13. See Section 2.12 for clutch adjustment procedure.

14. If the engine was removed, see Section 4 for engine installation.

15. If the engine was not removed:

- A. Replace the rear hitch arm.
- B. Mount the tire assembly(s).
- C. Remove jack stands.
- D. Reconnect engine cables, wiring harness, oil sensor switch, and fuel line.
- E. Put new fluid in transmission. See Section 2.10 for servicing.

3.16 Forward-Reverse Clutch Bearing Service

1. Remove the trunnion, bearing, disc assembly from the transmission.

2. Use a flange puller with three bolts positioned to fit the trunnion lip to press the trunnion off the bearing.

3. Turn the assembly over and remove the snap ring. (Older style clutch.)

4. Readjust the position of the three bolts to fit the bearing. Press the bearing off the disc assembly.

5. Inspect all parts. Replace any parts damaged or worn. See Figure 28.



FIGURE 28

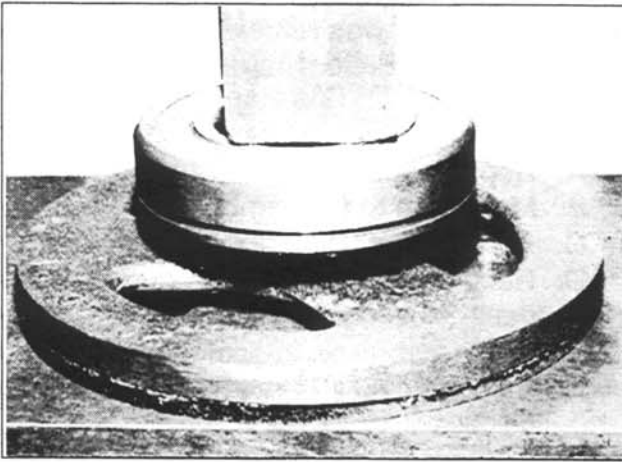

FIGURE 29

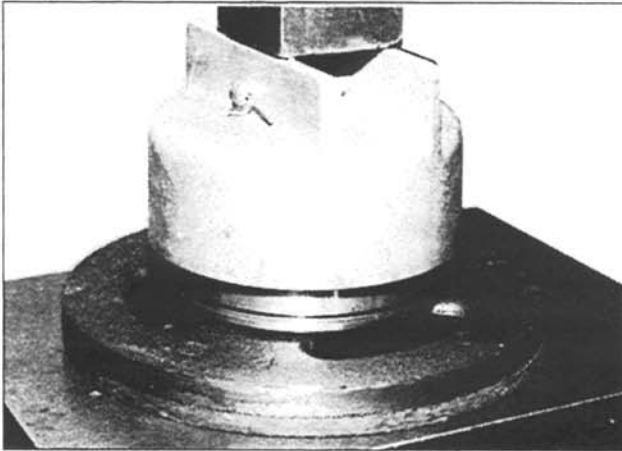

FIGURE 29A

6. Press the bearing on the disc assembly. See Figure 29.

7. Turn the assembly over and press the trunnion on the bearing. See Figure 29A.

3.17 Forward-Reverse Clutch Seal Replacement

Small Seal (18035):

1. Remove the trunnion, bearing and disc assembly.
2. Carefully remove the old seal with a small punch.
3. Put a film of grease on the lip of the new seal and slide it on the thimble (Figure 33 - Section 10). Coat outer area of seal with Loctite.
4. Put the thimble over the shaft and seat the seal with a driver (Figure 35 - Section 10).

Large Seal (17917):

1. The inside clutch hub must be removed to install this seal. Follow the procedure for removal of the clutch shaft in the transmission disassembly.
2. Remove the old seal.
3. Install the new seal with a driver (Figure 36 - Section 10). Coat outer area of seal with Loctite.
4. Assemble transmission.

SECTION 4

ENGINE

4.1 Refer to your engine service manual for adjustments and repair.

4.2 Engine Removal

1. Disconnect battery cables. Remove negative cable first.
2. Turn off fuel at fuel tank.
3. Remove the rear deck.
4. Disconnect the choke and throttle cables.
5. Disconnect the engine harness plug, oil sensor switch, and starter cable.
6. Disconnect the fuel line at the engine.
7. Remove rear hitch assembly. 4 bolts, 2 at each bearing retainer.
8. Place a jack under the engine to provide support during removal.
9. Remove the four bolts holding the engine to the frame.
10. Slide the engine rearward out of the transmission. Take care to keep the gear and bearing set on the crankshaft.

4.3 Adaptor Plate Removal/Installation (14-G)

1. Remove the gear, key, and bearing set.
2. Remove the four bolts which mount the adaptor plate off the pilot.
3. Use a soft hammer to remove the adaptor plate off the pilot.
4. Inspect the adaptor plate, bearing set and gear for damage and wear.

5. Replace any parts worn or damaged.

6. Remove all residue off the adaptor gasket from the engine and adaptor plate. Check oil seal for damage; if damaged replace seal. Put a film of grease on a new gasket and put it in place on the engine.

7. Slide the adaptor plate in place with the assistance of a soft hammer.

8. Start all four bolts and then tighten.

9. Replace the bearing set, key, and gear.

4.4 Engine Installation

1. Coat the engine pilot with gasket eliminator.
2. Set the engine on a jack. Adjust the jack so that the crankshaft is on the centerline of the hole in the transmission.
3. Slide the engine into the transmission. Rotate the forward clutch to mesh the bevel gears.
4. Install the four bolts and tighten.
5. Reverse the disassembly process for engine connections and replacement of the rear deck and hood.

SECTION 5

WHEEL AND WHEEL BEARINGS



To prolong bearing life, we recommend repacking the bearing with grease once a year.

5.1 Front Wheel Bearings Removal

1. Jack up the front of the tractor.
2. Remove the caps.
3. Remove the nut, washer, spacer, bearing, and wheel assembly for each spindle.
4. Use a piece of clean bar stock and a hammer to tap out the inside bearing and seal.

5.2 Front Wheel Bearing Inspection and Repair.

1. Thoroughly clean the wheel hub and other parts.
2. Replace any part which is worn or damaged.
3. If a bearing is replaced, also replace the bearing cup. Use a bearing puller to remove the bearing cups.

5.3 Front Wheel Bearing Installation

1. If removed, install new bearing cups with a driver. See Section 10. Pack the bearings with wheel bearing grease.

2. Lay the inside bearing in the cup and press a new seal in place.
3. Put a film of grease on the lip of the seal.
4. Clean the spindles.
5. Slide a spacer on the spindle followed by the wheel assembly.
6. Fill the wheel hub cavity with grease. Put the outside bearing in the cup followed with a spacer, flatwasher, and a nut.
7. Tighten the nuts, back off until the wheel turns freely. Replace the caps with the driver. See Section 10.

SECTION 6, 7 AND 8

ATTACHMENT LIFT

6.0 Manual Lift

6.1 Disassembly:

- A. Remove the set screw in the lift lever assembly.
- B. Apply liquid wrench to the shaft through the hole where the pawl is positioned.
- C. Loosen the two bolts holding the locator casting and remove.
- D. Fasten a gear/sheave puller to the lift lever assembly and remove.
- E. Disassemble the lift lever assembly by removing the grip and rotate the push rod counterclockwise to disengage the pawl.
- F. Remove the key and the snap ring from the shaft.
- G. Using a punch and hammer drive the pivot bushing outward from the frame.
- H. Slide the lift lever shaft weldment to the left. Lift up on the right end and pull from the frame.
- I. Inspect and replace all parts worn or damaged.

6.2 Assembly:

- A. Slide the left end of lift lever shaft weldment into the frame hole and move to the left. Lower the right end and slide into the right hole.
- B. Slide new pivot bushings on the shaft and start in the holes. Slide the lift lever on the shaft and drive the bushings into the frame.
- C. Put the snap ring on the key in the shaft.
- D. Reassembly the lift lever.
- E. Reassemble the locator casting and mount to the frame.
- F. Put the lift lever assembly on the shaft so as to align with the key. Use a soft hammer to drive in place while holding down on the push rod.
- G. Install the set screw and tighten the jam nut.

7.0 Hydraulic Lift (Barness Pump)



Always replace the hydraulic filter anytime there is service or maintenance performed on the hydraulic system.

7.1 Problem-solving Chart.

Observation	Possible Cause
1. Attachment will not raise.	Lift linkage jammed Hydraulic pump pressure too low Relief valve leaking Control linkage damaged or disconnected Low hydraulic fluid level Hydraulic pump drive failure Filter Plugged
2. Hydraulic lift has no down pressure	Damaged control linkage
3. Control will not move to the float position.	Control linkage damaged.
4. Control will not move to neutral position from power up or power down positions when released.	Control linkage damaged Control valve mounting hardware is too tight.
5. Continuous pressure on cylinder noted by relief valve squeal.	Bent control linkage
6. Attachment lowers slowly.	Dirt in control valve. Damaged control valve. Seals in hydraulic cylinder leaking.

7.2 Hydraulic Valve Removal:

- A. Clean the hydraulic lines and fittings. Disconnect hydraulic cylinder hoses. Use two wrenches to prevent damage to the fittings.
- B. Disconnect the control linkage.
- C. Disconnect the line to the pump and the line to the filter.

7.3 Installation of the Valve:

- A. Reverse the removal procedure. Start fittings with fingers to avoid cross-threading.
- B. Put clean new Dextron II ATF in the fittings.

7.4 Hydraulic Cylinder Removal:

- A. Clean the hydraulic fitting at the cylinder. Disconnect the hydraulic lines.
- B. Disconnect the piston from the lift lever weldment.
- C. Remove the snap ring and any rust from the left end of the hydraulic cylinder shaft. If the shaft is rusted, clean with sandpaper and lubricate.
- D. Use a soft hammer or a hammer and punch to drive the shaft to the right through the frame side and hydraulic cylinder. Take care not to pin the end of the shaft. This will cause it to bind in the frame or cylinder.

7.5 Hydraulic Cylinder Installation:

- A. Reverse the disassembly procedure. Start fittings with fingers to prevent cross-threading.
- B. Note that the bolt connecting the piston to the lift lever weldment must be loose enough to allow free rotation of the bolt.
- C. Check the hydraulic filter after the lift has been cycled and add Dextron II ATF if necessary.

7.6 Hydraulic Pump Removal:

- A. Raise the rear deck and left rear wheel.
- B. Put an oil pan under the pump.
- C. Clean the pump body, hydraulic lines, and fittings
- D. Disconnect the hydraulic lines. Use a second wrench on the fitting in the pump to prevent breakage.
- E. Remove the two socket cap screws retaining the pump.

- F. Using a soft hammer, gently tap the pump to free and remove.

7.7 Installation of the Hydraulic Pump:

- A. Reverse the disassembly.
- B. Start the hydraulic fittings with the fingers to prevent cross-threading.
- C. Add fresh, clean Dextron II ATF to the filter.

7.8 Hydraulic Pump Shaft Removal:

- A. Remove the hydraulic pump as described in Section 6.2.
- B. Remove the engine as described in Section 4.
- C. Remove the snap ring on the pump shaft.
- D. Put a shop cloth under the gear to catch the key and spacer if dropped. Tap the pump shaft inward with a soft hammer. When the key is exposed, rotate the shaft so that the key is on the top side. When the shaft passes through the outboard bearing, the gear, shaft and spacer can be pulled past the bevel gear on #1 shaft and out the rear of the transmission.



Note orientation of the two spacers (small inward - large outward).

- E. Replace the parts worn or damaged.

7.9 Hydraulic Pump Shaft Installation:

- A. Reverse the disassembly process.
- B. Service the filter with clean, fresh Dextron II or Dextron III ATF one inch from the top of filter.

7.10 Hydraulic Pressure Measurement and Adjustment:

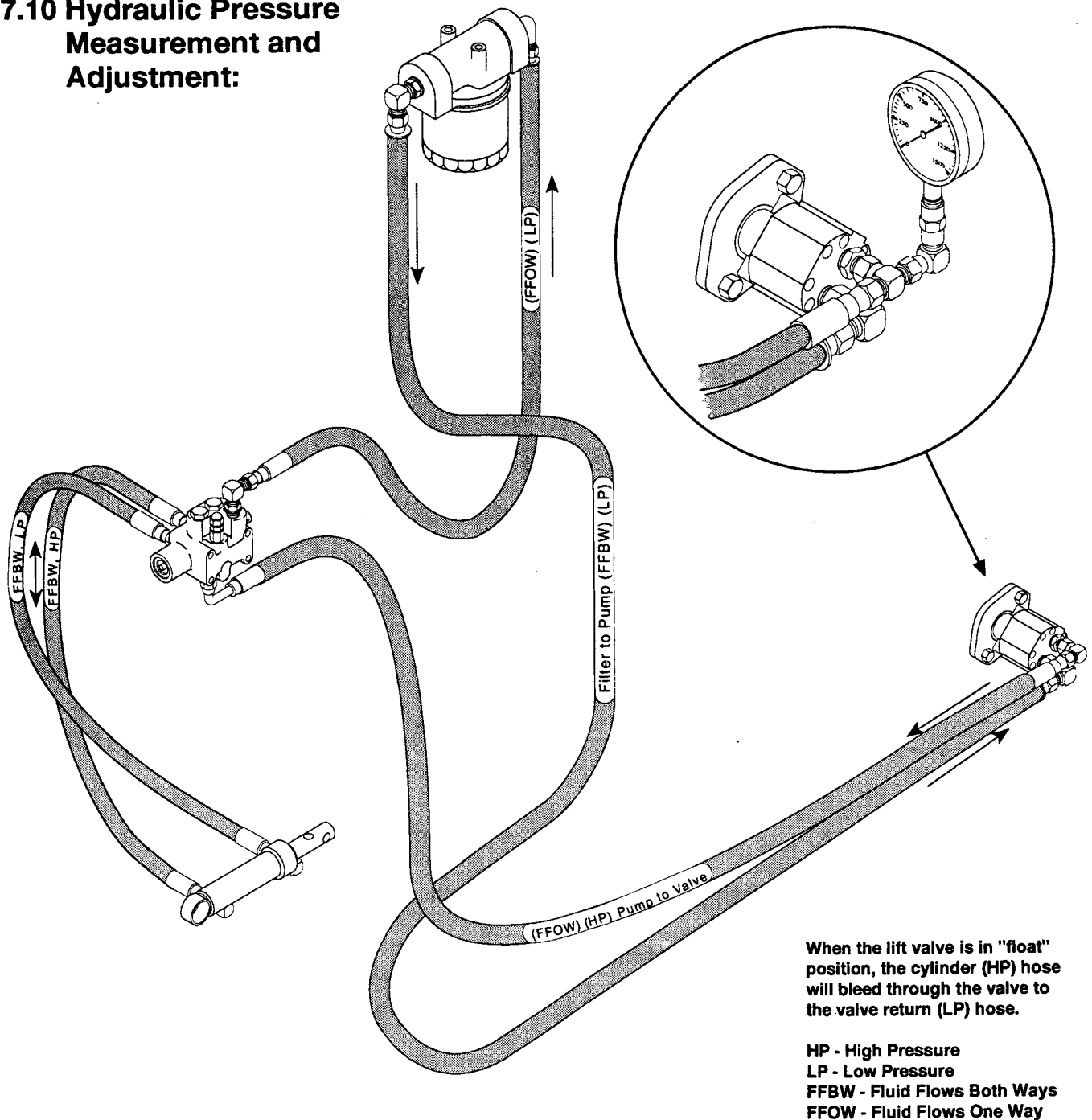

FIGURE 30 — Pressure Reading Needs to be 950-1050 PSI

- A. Remove the left rear wheel assembly.
- B. Remove the adaptor fitting at the pump outlet and install the pressure gauge. See Figure 30 Use two wrenches to avoid breaking the fittings. Pressure Gauge Kit is Part No. 39995 - Figure 40 - Section 10.
- C. Start the engine. Move the lift control to the "UP" position and hold. The pressure gauge should read 950 psi to 1050 psi.
- D. If the pressure reading is not correct, it can be adjusted with the relief valve in the hydraulic control valve assembly.
- E. Remove the acorn nut on the valve body. Loosen the jam nut while holding the adjusting screw with a screwdriver.

- F. Start the engine. Have another person hold the hydraulic lift control in the "UP" position while observing the pressure gauge. Rotate the adjusting screw clockwise to increase the pressure. Rotate the adjusting screw counterclockwise to reduce the pressure. Take care not to move the adjusting screw when tightening the jam nut.
- G. Reverse the disassembly procedure to reassemble.

- 1. Disconnect black ground wire at frame.
- 2. Remove switch from dash, leave the three leads connected to switch.
- 3. Clean hydraulic fittings and mark hoses to insure proper routing at time of pump installation.
- 4. Disconnect hydraulic hoses from pump



NOTE: Support electric/hydraulic lift pump when removing mounting bolts

8.0 Hydraulic Lift (Electric/Hydraulic Pump)



Remove attachment from tractor or disconnect attachment at mower lift arm prior to working on lift system. Replace hydraulic fluid after any maintenance has been performed on the lift system.

- 5. Remove the two mounting bolts and lift pump out of unit.
- 6. Drain hydraulic fluid through reservoir cap.
- 7. Repair as needed

8.1 Problem-solving chart.

UNITS WITH ELECTRIC/HYDRAULIC PUMP

Observation	Possible Cause
1. Attachment will not raise	Discharge Battery Loose connection to solenoid or ground
2. Attachment raises slowly	Hydraulic lines routed correctly. Refer to Chart 7

8.2 Electric/Hydraulic Pump Removal:



Disconnect battery negative terminal first

8.3 Electric/Hydraulic Pump Installation

- 1. Install pump with the two mounting bolts.
- 2. Reconnect hydraulic hoses. Refer to Figure 30 for proper routing.
- 3. Install switch into dash with green terminal to the top and blue terminal to the bottom.
- 4. Reconnect black ground wire to frame.
- 5. Remove cap and service hydraulic reservoir with Dextron II or Dextron III to full line. Install cap.
- 6. Reconnect battery. Negative terminal first.

8.4 Electric/Hydraulic Pump Switch Removal



Disconnect Battery, negative terminal first.

1. Remove switch from dash and disconnect the three leads.

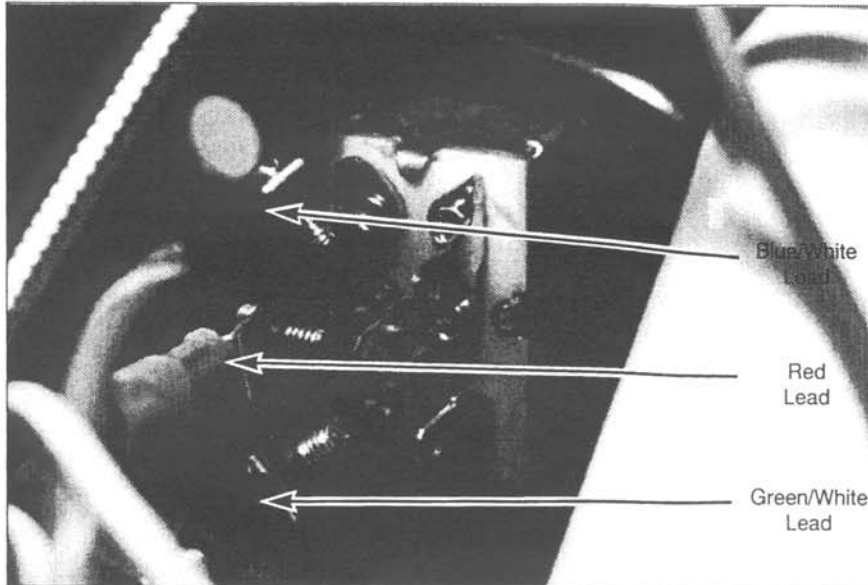

FIGURE 31

8.5 Electric/Hydraulic Pump Switch Installation

1. The switch can only be installed one way. Check orientation of switch for proper lead hookup.
2. Connect the three leads to the switch — green - top, red - middle, and blue - bottom. See Figure 31.
3. Install switch into dash, reconnect the battery, negative terminal first and check operational function of switch.

8.6 Hydraulic Hose Removal



When hydraulic pump is operated hydraulic fluid is under high pressure. To avoid injury disconnect battery (negative terminal first) prior to working on hoses.

1. Clean hydraulic fittings prior to removing hoses.
2. Disconnect hydraulic hose(s) from cylinder end first.
3. Disconnect hydraulic hose(s) from pump end.
4. Replace hoses as needed.

8.7 Hydraulic Hose Installation

1. Connect hydraulic hose(s) to pump first. Refer to hydraulic schematic for proper routing.
2. Connect hydraulic hose(s) to cylinder.
3. Connect battery, negative terminal first.
4. Cycle unit up and down a few times to bleed the system.
5. Add Dextron II or Dextron III to the full line on the reservoir if servicing is needed.

8.8 Hydraulic Cylinder Removal



When hydraulic pump is operated hydraulic fluid is under high pressure. To avoid injury disconnect battery (negative terminal first) prior to working on hoses.

1. Clean hydraulic fittings prior to removing hydraulic hoses.
2. Disconnect hydraulic hoses. Note orientation of hydraulic hoses.
3. Disconnect cylinder from mower lift weldment. Note which hole cylinder is connected to.

4. Remove the left side retaining ring from the hydraulic cylinder shaft.

5. Support hydraulic cylinder and slide hydraulic cylinder shaft out on the right side far enough to clear cylinder.

6. Remove cylinder from tractor.

2. Install left side retaining ring on cylinder shaft.

3. Reconnect hydraulic cylinder to mower lift weldment, noting where it was previously connected.

4. Connect hydraulic hoses, refer to Figure 32.

5. Service electric/hydraulic pump reservoir. Refer to Section 2.17.

8.9 Hydraulic Cylinder Installation

Note: Hydraulic ports for fittings need to be facing up.

1. Slide cylinder shaft through hydraulic cylinder and out through left side of tractor frame.

8.10 Hydraulic Pressure Measurement and Routing

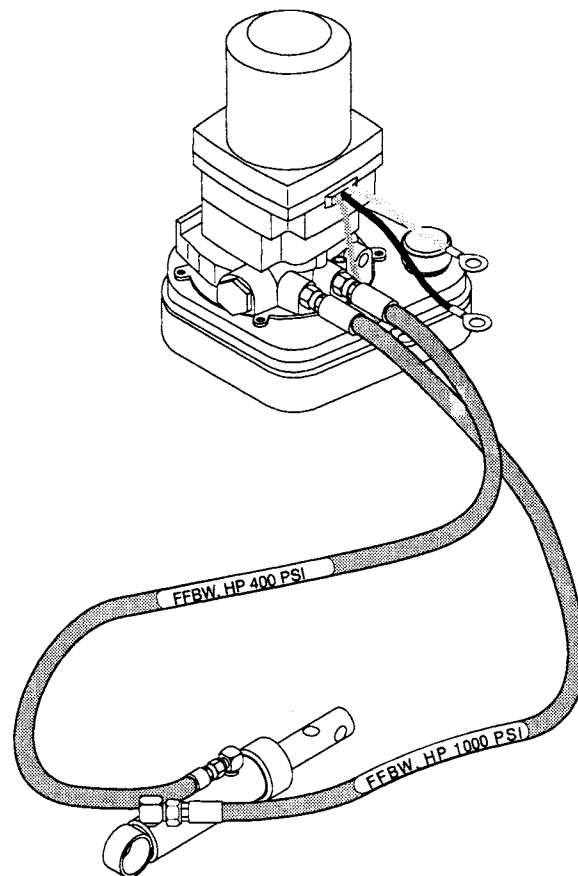

HP - High Pressure
FFBW - Fluid Flows Both Ways

FIGURE 32

SECTION 9

FUEL SYSTEM

9.1 Fuel Tank Removal

1. Raise the hood, and disconnect the battery ground.
2. Turn off fuel valve at the tank outlet, and disconnect fuel line.
3. Remove the four 7/16 bolts that hold tank brackets.
4. Lift tank up out of the frame.

9.2 Fuel System Inspection and Repair

1. Check the fuel tank, fitting and fuel line for damage.
2. Replace any worn or damaged parts. Replace the fuel tank if it is leaking. Welding on a fuel tank could result in an explosion.



NOTE - Welding on a fuel tank could result in an explosion. Replace tanks if leak exists.

9.3 Fuel Tank Installation

1. Reverse the disassembly process to reassemble.
2. Make sure the fuel tank is centered in the frame.

SECTION 10

BRAKES

10.1 Brake Removal

1. Raise the rear deck.
2. Remove the right rear wheel assembly. This is not necessary but will provide easy access to the brake.

3. Remove the 3/4" bolt and brake band.

10.2 Brake Repair and Inspection.

1. Inspect the brake parts and linkage. Replace any part worn or damaged.
2. Replace the brake band when the lining is as thin as the thickness of the ignition key (about .070").

10.3 Brake Installation

1. Reverse the disassembly procedure.
2. See Section 2.11 for adjustment.

SECTION 11

ELECTRICAL

11.1 Electrical Problem-solving Chart

Observation	Possible Cause
1. No sound or motion when the ignition switch is turned to the "START" position.	PTO control in the "ON" position Direction control pedal in the forward or reverse position. Blown fuse Discharged battery Bad relay Loose battery cable(s) Damaged time delay module
2. When the ignition switch is turned to "START," the solenoid "clicks" and the engine starter motor does not operate.	Discharged battery Battery cable connector(s) corroded Starter damaged
3. When the ignition switch is turned to "START," the starter operates but the engine does not start.	Relay or relay connection(s) Fuel tank empty Fuel valve turned off Engine spark plug(s) fouled Engine failure — See Engine Service Manual
4. Battery discharged	Regular-rectifier failure Fuse holder or battery Engine alternator failure Battery failure
5. Engine continues to run when the ignition switch is rotated to the "OFF" position.	Ground wire not connected Ignition switch failure
6. Lights do not come on when the light switch is moved to the "ON" position.	Light(s) burned out Defective light switch Loose wire connections Engine light alternator failure Ignition switch failure
7. Engine runs rough or stops after it gets hot.	See Engine Service Manual Time delay failure
8. Fuse blows when starting engine.	Dead short in system

11.2 Wiring Diagram:

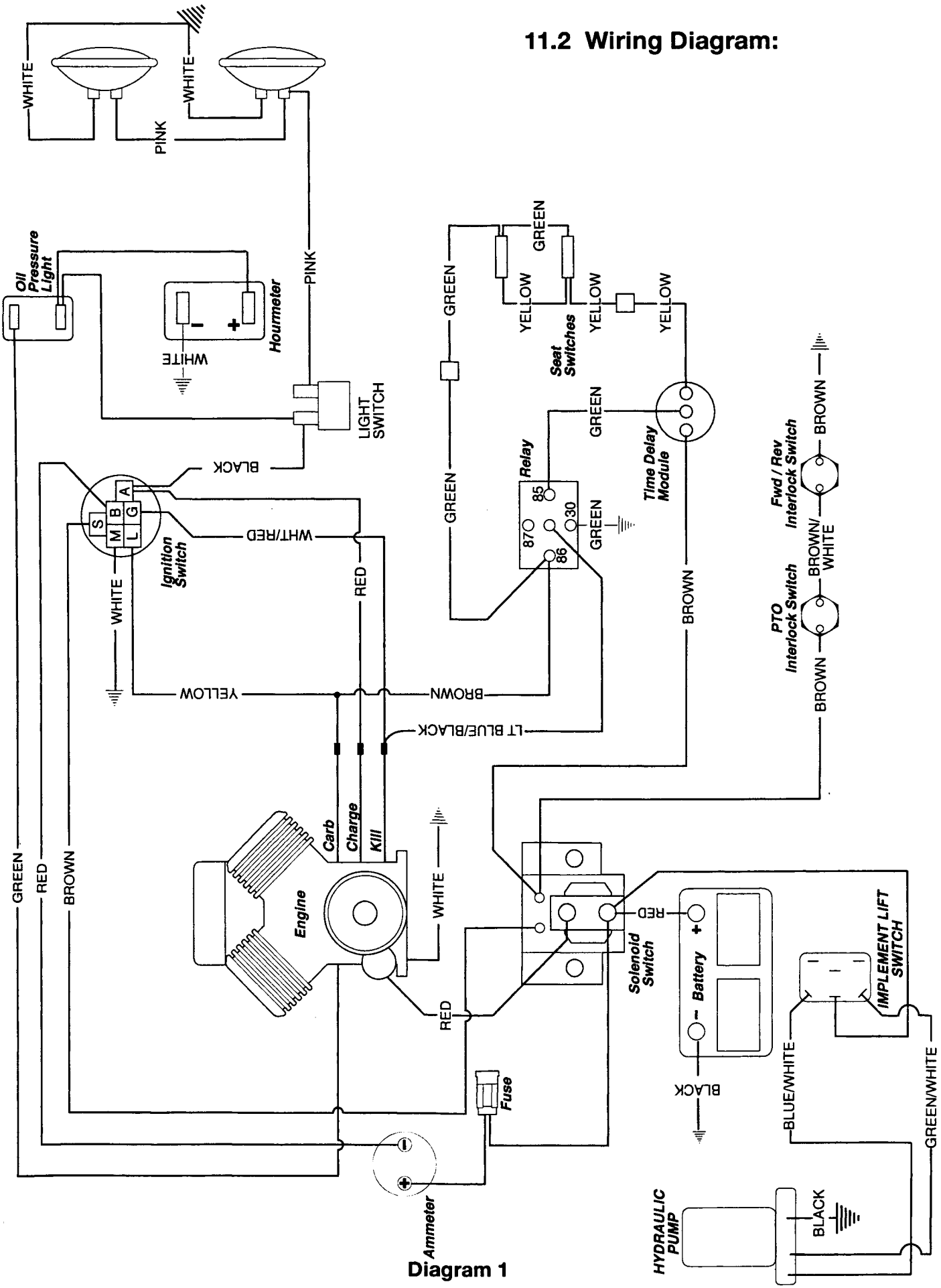

Diagram 1

11.2 Wiring Diagram:

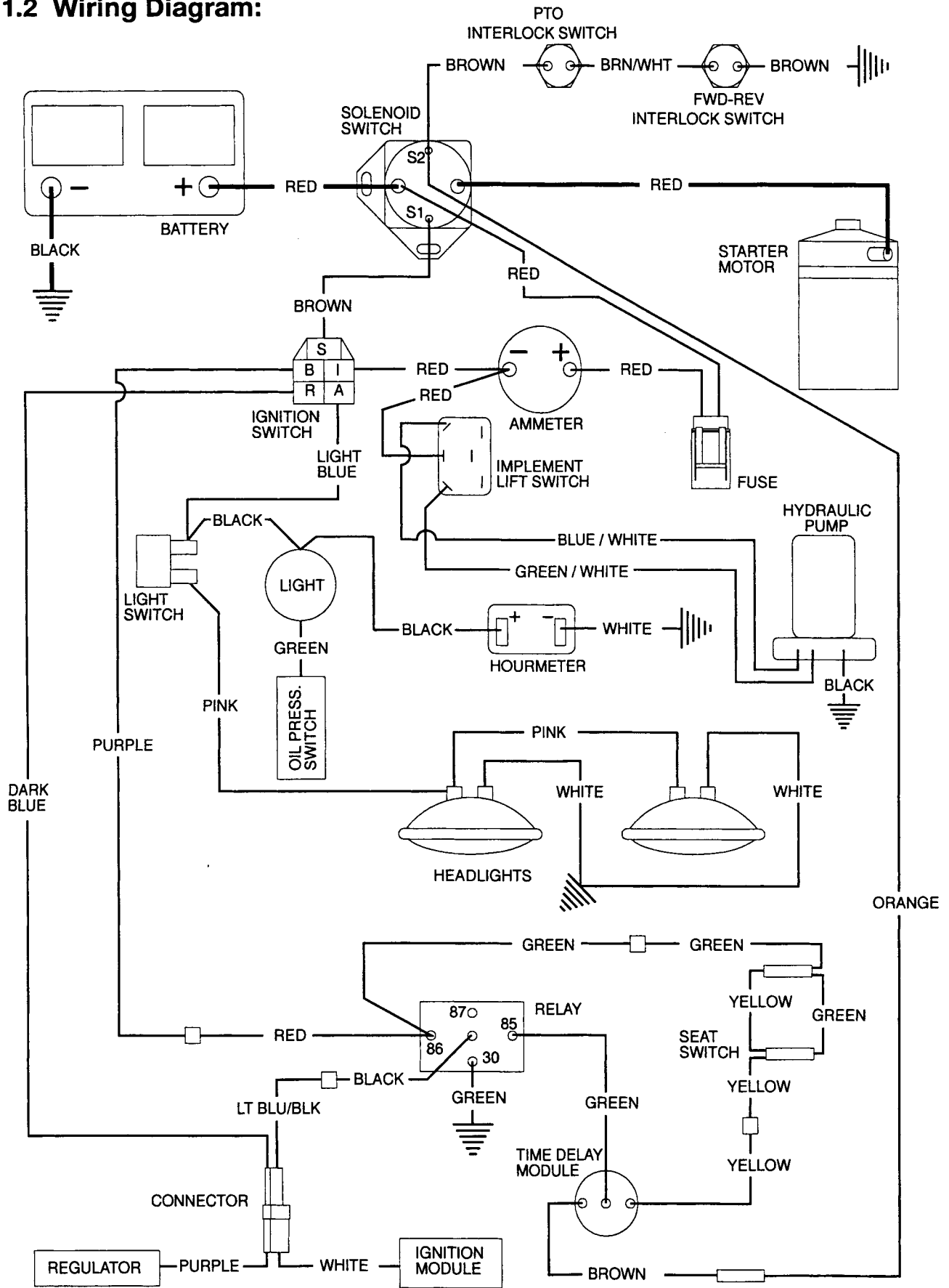
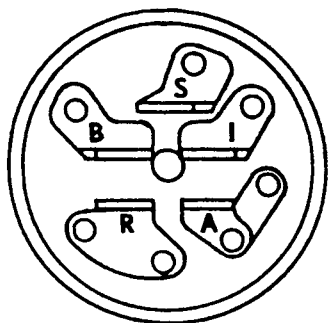

Diagram 2

11.3 Ignition Switch

FUNCTION DIAGRAM



Key Position	Function	Circuit
1	Off	None
2	Start	B+R+I+S
3	Run	B+R+I+A

Diagram 3

Check out procedure:

- Unplug the ignition switch and remove it from the instrument panel.
- Set a VOM in the ohm (Rx1) position. Connect one lead to the "B" pin.
- Turn the ignition key to position 1. Sequentially touch pins R, I, A, S and the case with the free meter lead. No circuit (infinity) should be indicated.
- Turn the key to position 2 and hold. Sequentially touch pins R, I, and A with the free lead. A circuit (zero ohms) should be indicated. Touch the free lead to the case. No circuit (infinity) should be indicated.
- Turn the key to position 3. Sequentially touch pins R, I, and S with the free lead. A circuit (zero ohms) should be indicated. Touch the free lead to the case. No circuit (infinity) should be indicated.
- Replace the switch if the switch fails the above tests.

NOTE: Make all voltage checks in reference to the battery voltage, 12 volts at battery, should be 12 volts at electrical component being checked. Anything more than a 1/2 volt drop indicates burnt

contacts, or failing component in system.

11.4 Interlock Switch

- Remove the subject interlock switch from the tractor.
- Set a VOM switch in the ohm (Rx1) position.
- Connect the meter leads to the switch pins.
- No circuit (infinity) should be indicated.
- Push in on the interlock switch plunger. A circuit (zero ohms) should be indicated.
- Connect one lead to the case and sequentially touch the switch pins with the other lead. No circuit (infinity) should be indicated.

- Replace the switch if it fails the above test.

11.5 Fuse Holder

- Use a VOM with the switch set in the ohm (Rx1) position.
- Make a visual check of the fuse to determine that it is not burned out. If the glass is clouded, check with an ohmmeter (zero ohms).
- Unplug the fuse holder and connect the ohmmeter to the pins. A circuit (zero ohms) reading should be indicated.
- If no circuit is indicated, replace the fuse holder.

11.6 Battery

- Detailed information on battery design, service, voltage check, and hydrometer use can be found in the Battery Service Manual published by the Battery Council International, 111 East Wacker Drive, Chicago, Illinois 60601.

2. On a standard battery, measure the voltage and specific gravity of the battery. Replace the battery if it fails the voltage or specific gravity test. See the schedule in Diagram 4. **NOTE: The voltmeter used must be calibrated to give an accurate reading and the hydrometer reading must be corrected to a temperature of 80°F (26.7°C).**

Charge Level	Specific Gravity	Voltage
100%	1.265	12.7
75%	1.225	12.4
50%	1.190	12.2
25%	1.155	12.0
Discharged	1.120	11.9

Diagram 4

3. On low water loss batteries, if voltage is below 12.4 or the specific gravity is below 1.225 after charging, replace the battery. If the battery has a built-in hydrometer, follow the instructions on the battery.

11.7 Ammeter

1. Remove and clean the electrical connection. Inspect for damage.
2. Replace the ammeter if it is damaged or does not function after cleaning.

11.8 Hourmeter

1. Check and clean the electrical connections. Inspect for damage.
2. Turn the ignition key to the "ON" position. The hourmeter should "tick."
3. Replace the hourmeter if it does not operate.

11.9 Solenoid Switch

1. Inspect and clean all wire connections.
2. Connect a VOM set in the 12 volt D.C. position to the post to which the starter cable is connected and to the

solenoid case. Turn the ignition switch to the "S" position. If a voltage is indicated, the solenoid switch is functional.

3. If check number "2" is not met, connect the voltmeter to the small post that is connected to the ignition switch. Turn the ignition switch to the "S" position. A voltage should be indicated. If the switch passes this test (voltage to the coil) and fails the test in number 2, replace the solenoid switch.

11.10 Regulator-Rectifier.

See the Engine Service Manual.

11.11 Relay

1. Inspect and clean all wire connections.
2. Turn key to "Run" position. Listen for relay to click. If relay clicks it is most likely okay. Further relay checks at #5.
3. If relay doesn't click with key in the "run" position use a VOM set to "Ohms" (Rx1) position and verify continuity to ground at terminal "85." If continuity to ground exists go on to #4. If not, make sure all interlock switches on path to ground are functional and set right (closed position).
4. Once continuity to ground is achieved, set the VOM to 12 volts D.C. position "key in run" position and check voltage at terminal "86."

5. Check "Ohms" between terminals 86-85 should read (Ohms 87-105). Check "Ohms" between terminals 30-87A should read (.1) Ohm. Key in "Run" position 30-87A should read (Open). Energize relay. Check "Ohms" between terminals 30-87 should read (.1) Ohms; 30-87 should read (Open).

11.12 Time Delay Module

1. Inspect and clean all wire connections.
2. Turn key to "Run" position, check resistance (Ohms) between the green and brown wire. With the seat switch open it should read "Open" (infinite).

3. Turn key to "Run" position, check resistance (Ohms) between the green wire and brown wire. With the seat switch closed it should read "Closed." (.1).

4. If Steps 2 and 3 are met, time delay is okay. If not replace time delay.

11.13 Electric/Hydraulic Pump Switch

1. Inspect and clean all wire terminal connections.

2. If no deck movement with activation of switch, verify with a volt/ohm meter 12 volts from terminal B to ground.

3. Check continuity to ground from terminals D and F, each in turn.

4. If these checks are correct, disconnect battery, activate switch, in both directions and check for .1-.3 ohms resistance between terminals B & D and also B & F when lever positioned respectively.

SECTION 12

SPECIAL TOOLS

12.1 Tool Identification

1. Axle: Seal (18031) - Driver - Figure 31
- Thimble - Figure 32

Hub (18052) - 3-Jaw Puller - OTC #1037*

* Reference OTC catalog #A-83
OTC Tools and Equipment
Division of Owatonna Tool Company
Owatonna, MN 55060

2. Brake shaft (Shaft #6): Seal (15137) - Thimble - Figure 33
- Driver - Figure 34

3. Fwd-Rev Clutch (Shaft #1, Shaft #2):

Seal (18035) - Thimble - Figure 33
- Driver - Figure 35

Seal (17917) - Driver - Figure 36

Bearing (18042) Removal - Flange Puller - OTC #518

4. PTO: Clutch - Spring Compressor - Bearing Puller - OTC #1123
- Push-Puller - OTC #927
- Push-Puller Legs - OTC #1101

Cap - Seal (15137) - Thimble - Figure 33
- Driver - Figure 34

Output Shaft - Seal (17923) - Driver - Figure 37
- Bearing Cup - Puller - OTC #1150
- Slide Hammer - OTC #1155
- Driver - OTC #27793
- Snap Ring - Clamp - Figure 38

5. Lift Lever Removal: Bearing Puller - OTC #1123
Push-Puller - OTC #927

6. Wheel, Front: Bearing Cup - Puller - OTC #1150
- Slide Hammer - OTC #1155
- Driver - OTC #27793

Seal (18447) - Driver - OTC #27793
Cap (18449) - Driver - Figure 39

12.2 Tool Illustrations

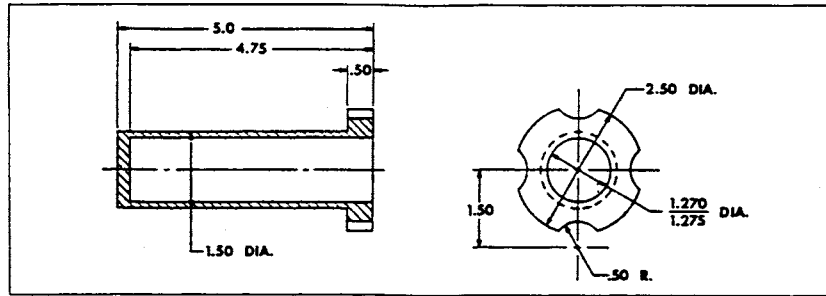

Seal Driver - Axle
FIGURE 31

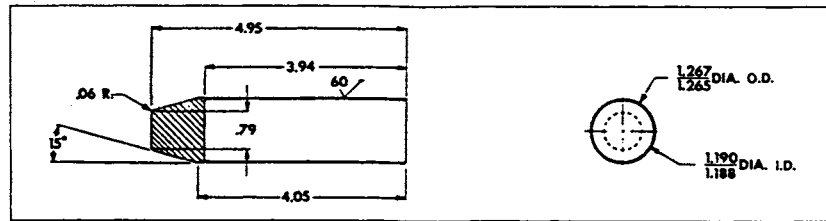

Seal Thimble - Axle
FIGURE 32

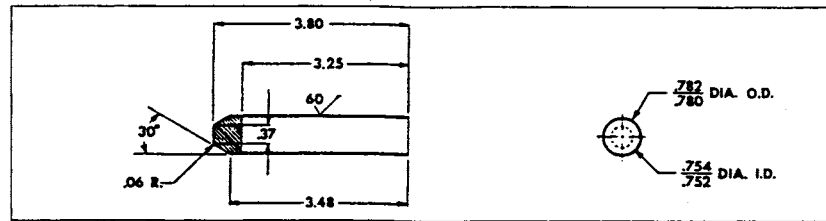

Seal Thimble - Brake Shaft Seal
- PTO Cap Seal
- Fwd/Rev Clutch Seal (18035)
FIGURE 33

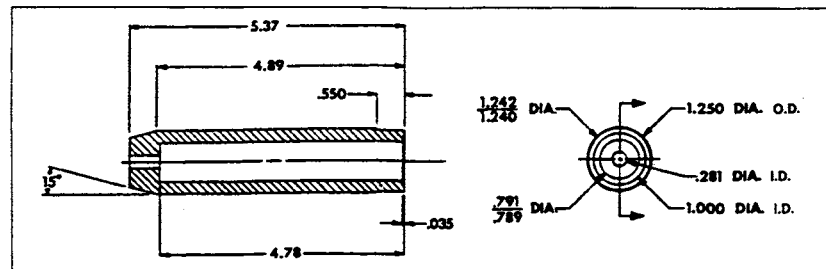

Driver - PTO Cap Seal (15137)
- Brake Shaft Seal (15137)
FIGURE 34

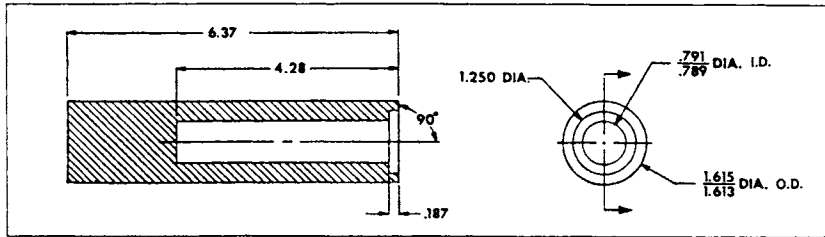

Driver - Fwd/Rev Clutch Seal (18035)
FIGURE 35

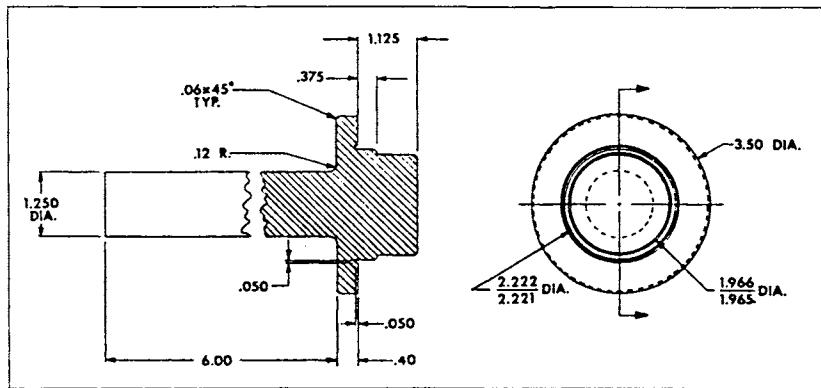

Driver - Fwd/Rev Clutch Seal (17917)
FIGURE 36

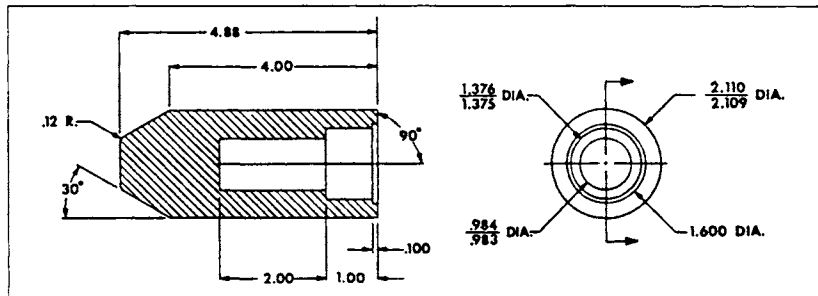

Driver - PTO Output Shaft Seal (17923)
FIGURE 37

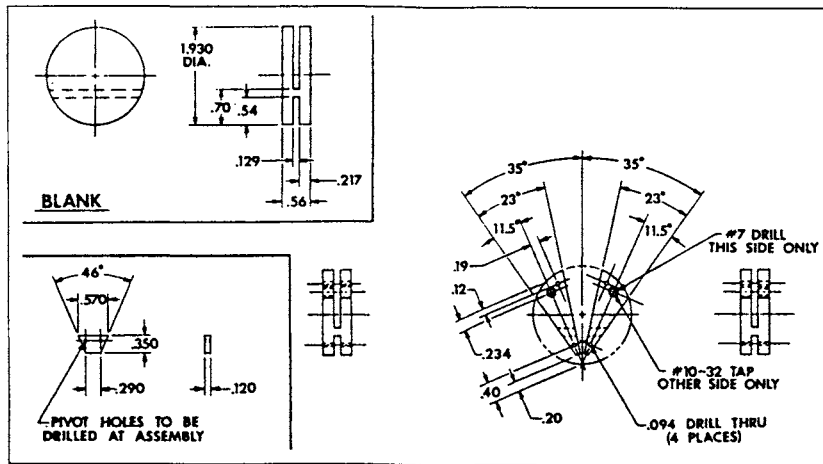

**Retaining Ring Clamp - PTO Bearing Set
FIGURE 38**

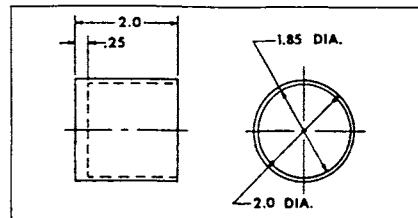

**Driver - Front Wheel Cap
FIGURE 39**

12.3 Hydraulic Gauge and Fittings

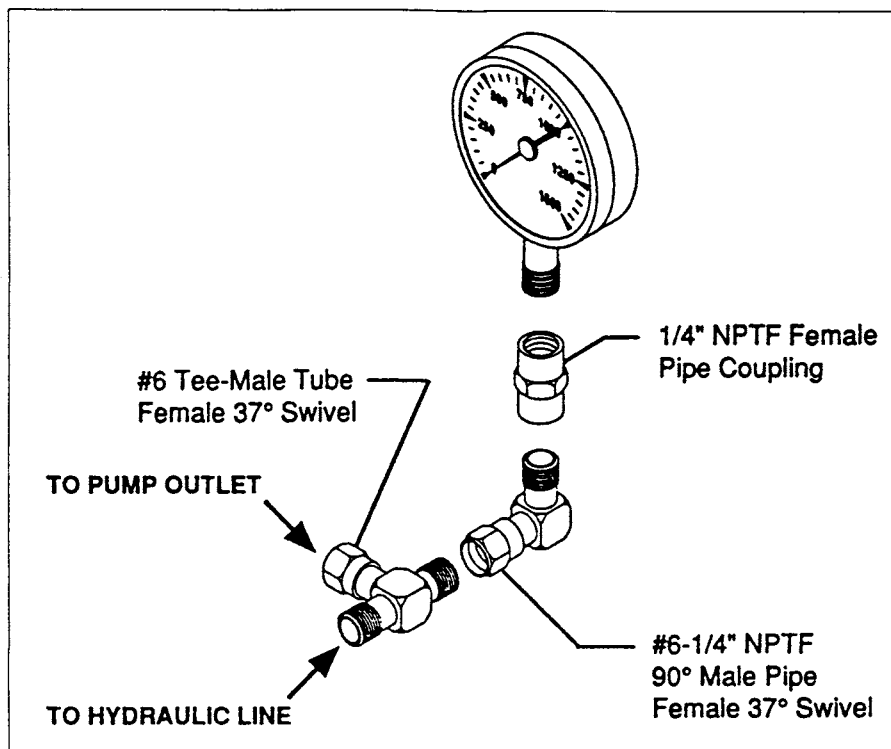

FIGURE 40