

***GRAVELY***  
**Model "L"**  
**Tractor**

**PARTS AND  
PRICE LIST**

**TRACTORS WITH MFG. NOS. BEGINNING A-1, B-1, C-1, D-1 . . .SEE NAMEPLATE**

**Effective Date**

**APRIL 1, 1961**

***GRAVELY TRACTORS***

Division of Studebaker-Packard Corporation

**DUNBAR. WEST VIRGINIA**

U. S. A.

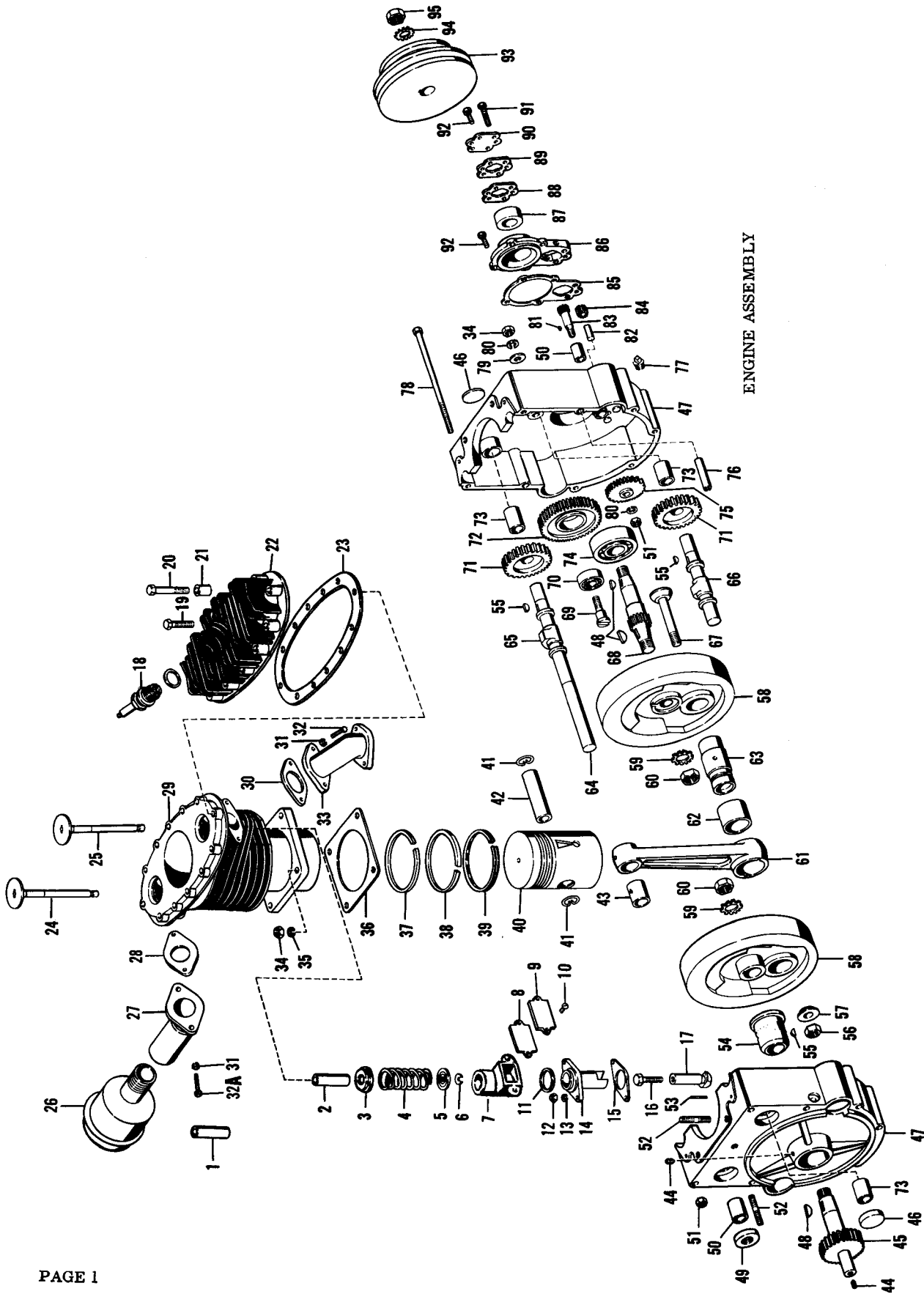

ENGINE ASSEMBLY

Item No.	Part No.	Description	Quan. Req'd.	Price
1	L-881-X	Valve Guide, bronze	1	\$1.00
2	L-881-N	Valve Guide, cast iron	1	.60
3	L-882	Valve Spring Locator Sleeve	2	.10
4	L-312	Valve Spring	2	.24
5	5741	Valve Spring Cap	2	.14
6	5742	Valve Spring Cap Key	2	.08
7	L-875	Valve Cover	2	1.00
8	L-879	Valve Cover Gasket	2	.05
9	L-878	Valve Cover Cap	2	.10
10	101-S	Valve Cover Cap Bolt	4	.02
11	L-877	Lower Cover Gasket	2	.10
12	202-N	Nut	4	.02
13	303-W	Lock Washer	4	.01
14	L-403	Valve Plunger Guide	2	1.74
15	L-407-A	Valve Plunger Gasket	2	.06
16	L-880	Valve Tappet Screw	2	.20
17	L-404	Valve Plunger	2	1.21
18	1709	Spark Plug and Washer	1	.84
19	154-S	Cylinder Head Bolt, short	10	.06
20	155-S	Cylinder Head Bolt, long	2	.06
21	L-840	Cylinder Head Bolt Sleeve	2	.09
22	5734	Cylinder Head	1	5.78
23	5735	Cylinder Head Gasket	1	.67
24	L-311-X	Valve, exhaust	1	1.08
25	L-311-N	Valve, intake	1	.94
26	L-816	Muffler	1	2.07
27	L-301-D	Manifold, exhaust	1	1.66
28	L-407-C	Manifold to Cylinder Gasket, exhaust	1	.06
29	5733	Cylinder	1	21.56
30	L-407-B	Manifold to Cylinder Gasket, intake	1	.06
31	303-W	Manifold Bolt Lock Washer	4	.01
32	164-S	Manifold Bolt, intake	2	.02
32-A	164-SG	Manifold Bolt, Graphited, exhaust	2	<b>.04</b>
33	L-301-A	Manifold, intake	1	1.66
34	206-N	Cylinder Stud Bolt Nut and Idle Gear Stud Nut	5	.02
35	306-W	Heavy Lock Washer for Cylinder Stud	4	.01
36	L-317	Cylinder Bottom Gasket	1	.09
37	LH-548	Chromed Compression Ring	1	.88
38	LH-547	Compression Ring	1	.41
39	LH-546	Oil Ring	1	.88
40	LH-543	Piston with Pin	1	6.26
41	LH-545	Piston Pin Lock	2	.01
42	LH-544	Piston Pin	1	1.16
43	L-306-A	Connecting Rod Bushing	1	.45
44	803-A	Crankcase Bushing Set Screw	1	.13
45	L-109	Drive Pinion Shaft	1	5.39
46	L-414	Expansion Plug	3	.10

Item No.	Part No.	Description	Quan. Req'd.	Price
47	L-101-2	Crankcase (Matched set, inner & outer)	1	30.32
48	504-K	Drive Pinion Shaft Key	2	.02
49	L-412	Cam Shaft Oil Seal	1	.59
50	L-406-I	Crankcase Bushing (use with Oil Seal)	1	.31
51	220-N	Oil Pump Master Gear Nut	1	.02
52	L-303	Cylinder Stud Bolt and Crankcase Stud Bolt	5	.13
53	L-405	Plunger Guide Stud	4	.13
54	L-117	Drive Pinion Bearing	1	2.09
55	503-K	Cam Shaft Gear Key and also for L-117	3	.02
56	209-N	Spreader Bolt Nut	1	.06
57	L-107	Spreader Bolt Washer	1	.40
58	L-104	Flywheel	2	5.39
59	L-113	Flywheel Nut Lock Washer	2	.06
60	L-112	Flywheel Nut	2	.14
61	L-863	Connecting Rod complete with Bushings	1	4.43
62	L-306-B	Connecting Rod Bushing, large	1	.91
63	L-105	Crank pin	1	2.81
64	L-810-A	Magneto Shaft Extension	1	.68
65	L-402	Exhaust Cam Shaft	1	3.03
66	L-424	Intake Cam Shaft	1	3.03
67	L-106	Spreader Bolt	1	.44
68	L-110	Timing Pinion Shaft	1	5.39
69	L-417	Bearing Stud	1	.36
70	L-416	Idler Gear Bearing	1	1.88
71	L-413	Cam Shaft Gear	2	2.09
72	L-415	Idler Gear	1	2.76
73	L-426	Cam Shaft Bushing, use with Expansion Plug	3	.31
74	L-115	Timing Pinion Bearing	1	3.91
75	L-419-A	Oil Pump Drive Gear	1	1.53
76	L-120	Crankcase Dowel	2	.19
77	701-P	Crankcase Drain Plug	1	.07
78	L-116	Crankcase Bolt	8	.18
79	403-W	Idler Gear Stud Flat Washer	1	.01
80	305-W	Lockwasher	5	.01
81	507-K	Oil Pump Master Gear Key	1	.02
82	L-855	Idler Gear Stud	1	.13
83	L-853	Oil Pump Master Gear	1	2.45
84	L-854	Oil Pump Idler Gear	1	.98
85	L-125	Bearing Cap Gasket	1	.05
86	L-850	Bearing and Pump Cap	1	3.48
87	L-126-A	Bearing Cap Double Seal	1	1.16
88	L-852	Gasket, 1/64" thick, (Pump Cover)	1	.04
89	L-852-A	Pump Cover Shims, .005 thick	opt.	<b>.03</b>
90	L-851	Pump Cover	1	.40
91	185-S	Bearing Cap Bolt, long	3	.07
92	164-S	Bearing Cap and Cover Bolts, short	4	.02
93	5745	Fan Drive Pulley	1	5.23
94	309-W	Fan Drive Pulley Nut, Lock Washer	1	.02
95	218-N	Fan Drive Pulley Nut	1	.10

LUBRICATION CHANGEOVER: During 1958 a change in lubrication was made, which will influence the ordering of several parts for repairs. This change is best recognized by the style of Oil Filter on your Tractor. If the Filter is a screw-on can and it may be removed without disconnecting the fittings, the repair parts apply as shown in the previous parts listings and illustrations. However, if you have the older style system (best recognized by oil lines and fittings mounted directly into the Oil Filter) the following instructions apply for repair parts:

<u>Part No.</u>	<u>Description</u>	<u>Price</u>
L-101-2	Crankcase, specify "old style"	30.32
L-306	Connecting Rod, (instead of L-863)	4.43
L-421	Oil Pump Master Gear, (instead of L-853)	2.45
L-422	Oil Pump Idler Gear (instead of L-854)	.98
L-423	Idler Gear Stud (instead of L-855)	.13
L-103	Bearing & Pump Cap (instead of L-850)	3.48
L-815-A	Relief Valve (instead of L-856)	.67
L-815-B	Relief Valve Plunger (instead of L-865)	.51
L-812	Oil Filter (instead of L-857)	3.03
L-813-E	Oil Line (instead of L-859)	.22
L-813-C	Oil Line (instead of L-861)	.22
L-813-F	Oil Line (instead of L-860)	.22
5737-B	Valve Guide (instead of L-881-N)	1.75
5737-B	Valve Guide (instead of L-881-X)	1.75
L-318	Sleeve Spring (instead of L-875)	.18
L-315	Upper Spring Sleeve (instead of L-875)	.39
L-316	Lower Spring Sleeve (instead of L-875)	.39

Note: Write for Changeover Bulletin giving procedure to changeover any Tractor to the heavy duty Oil Pump and Full-Flow Oil Filter.

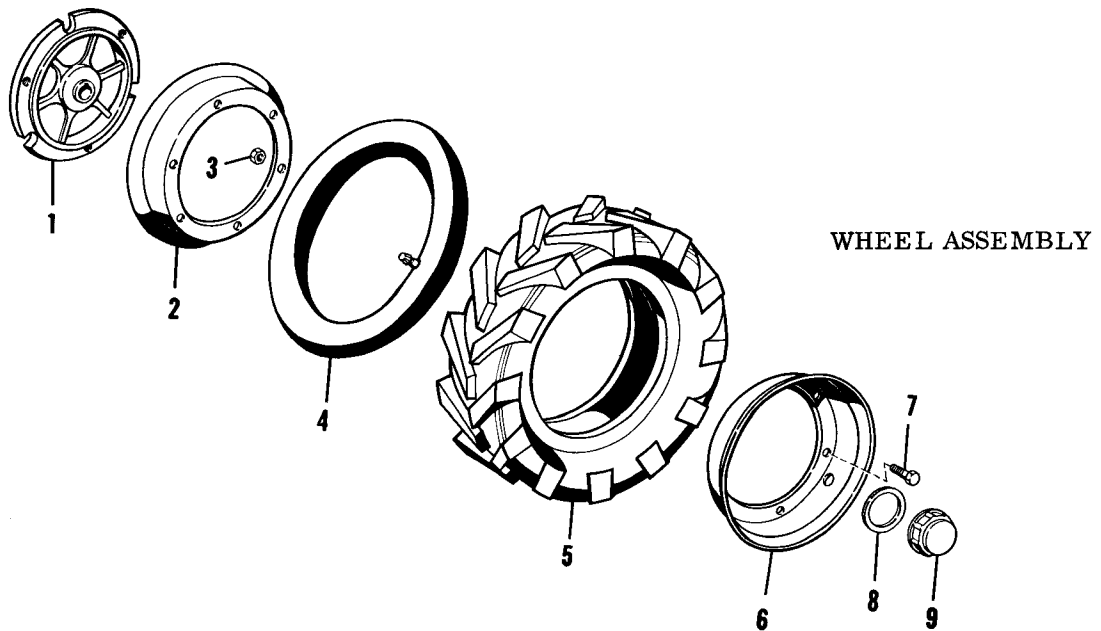

Item No.	Part No.	Description	Quan. Req'd.	Price
1	L-614-B	Wheel Hub	2	\$ 3.41
2	L-616-IR	Inner Rim	2	1.38
3	3509	Rim Bolt Nuts	6	.03

Item No.	Part No.	Description	Quan. Req'd.	Price
4	L-616-TU	Tractor Tire Tube	2	2.78
5	L-616-TI	Tractor Tire, sure grip or studded	2	11.22
6	L-616-OR	Outer Rim, (with valve hole)	2	1.38
7	179-S	Rim Bolts	6	.08
8	L-613	Hub Cap Washer	2	.04
9	L-619	Hub Cap	2	.06

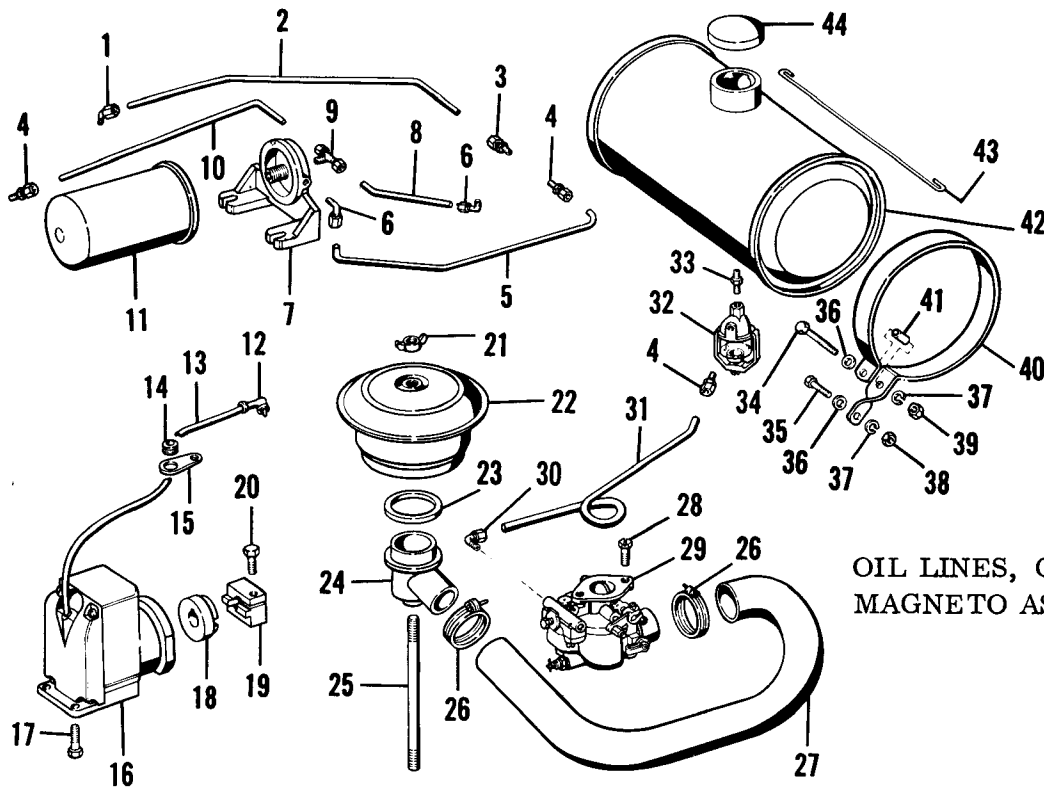

Item No.	Part No.	Description	Quan. Req'd.	Price
1	L-814-F	Elbow, Oil Strainer Body to Oil Line	1	\$ .31
2	L-813-A	Oil Intake Line, Strainer to Pump	1	.22
3	L-814-A	Pump Inlet Connector	1	.22
4	L-707	Relief Valve and Pump Line Connector	2	.19
5	L-859	Oil Line, Pump to Filter	1	.22
6	L-814-DL	Filter Supply and Engine Elbow, long style	2	.22
7	L-858	Oil Filter Bracket	1	1.75
8	L-860	Oil Line, Filter to Engine	1	.22
9	L-814-C	Discharge Line Tee	1	.39
10	L-861	Oil Line, Filter to Relief	1	.22
11	L-857	Oil Filter	1	2.60
12	1726	Spark Plug Rubber Cover	1	.28
13	1731	Magneto Cable	1	.42
14	L-827	Rubber Grommet	1	.06
15	L-826	Cable Bracket	1	.14
16	L-808	Magneto	1	35.60

When ordering parts for Carburetor or Magneto repair, be sure to specify the make and model number of the Carburetor or Magneto. Secure this information directly from the small name plate attached to the Carburetor and Magneto.

17	110-S	Magneto to Chassis Bolt	2	.07
18	L-809-F	Magneto Fibre Float Member	1	1.21
19	L-811	Magneto Coupling Steel	1	1.40
20	154-S	Magneto Coupling Bolt	1	.06
21	L-819-F	Wing Nut	1	.09
22	L-832	Oil Bath Air Cleaner	1	5.37
23	L-834	Gasket	1	.11
24	L-833	Air Filter Bracket	1	.99
25	L-819-E	Air Filter Bolt	1	.13
26	L-836	Air Filter Hose Clamp	2	.11
27	L-835	Air Filter Hose	1	1.54
28	126-S	Carburetor Bolt	2	.06
29	L-806-Z	Carburetor - Zenith	1	15.54
30	L-814-D	Elbow, Carburetor to Gas Line	1	.22
31	L-706	Gas Line	1	.22
32	L-705	Gas Strainer Complete	1	1.75

Gas Strainers (name of strainer cast into strainer body)

Tillotson		Crippen		Description
Part No.	Price	Part No.	Price	
L-705-A	\$ .65	L-705-H	\$ .42	Gas Shutoff Valve
L-705-B	.22	L-705-I	.22	Glass Bowl
L-705-C	.20	L-705-M	.25	Bowl Nut
L-705-D	.20	L-705-K	.14	Wire Screen
L-705-E	.75	L-705-L	.34	Cast Body
L-705-F	.45	L-705-J	.28	Bale Assembly
L-705-G	.08	L-705-N	.03	Gasket

Item No.	Part No.	Description	Quan. Req'd.	Price
33	L-814-E	Gas Filter Nipple	1	.13
34	149-S	Tank Band Bolt - Long	2	.08
35	164-S	Tank Band to Fan Housing Bolt	2	.02
36	401-W	Washer Tank Band	2	.01
37	<b>304-W</b>	Tank Band Bolt Lock Washer	2	.01
38	242-N	Nut, Tank Band to Housing Bolt	2	.06
39	<b>233-N</b>	Tank Band Bolt Nut	2	.08
40	5164 L & R	Tank Band (Right and Left)	2	.50 ea.
41	L-121	Tank Band Spacer	2	.19
42	L-701	Gas Tank	1	6.38
43	L-225	Tank Band Hook	1	.05

Oil Pressure Gauge (optional equipment)

- A. New style Lubrication System on Tractors starting in 1958 (Manufacturing Number B-7620) or on all Tractors converted to heavy duty Oil Pump and Full-Flow Oil Filter.

Part No.	Description	Price
	Gauge Complete	\$3.00
L-866	Oil Gauge only	2.50
L-867	Oil Gauge Adapter	.50

- B. Older style Tractors before 1958 (Manufacturing Number B-7620) Tractors with older style Oil Pump and partial Flow Oil Filter, specify Oil Pressure Gauge--old style.

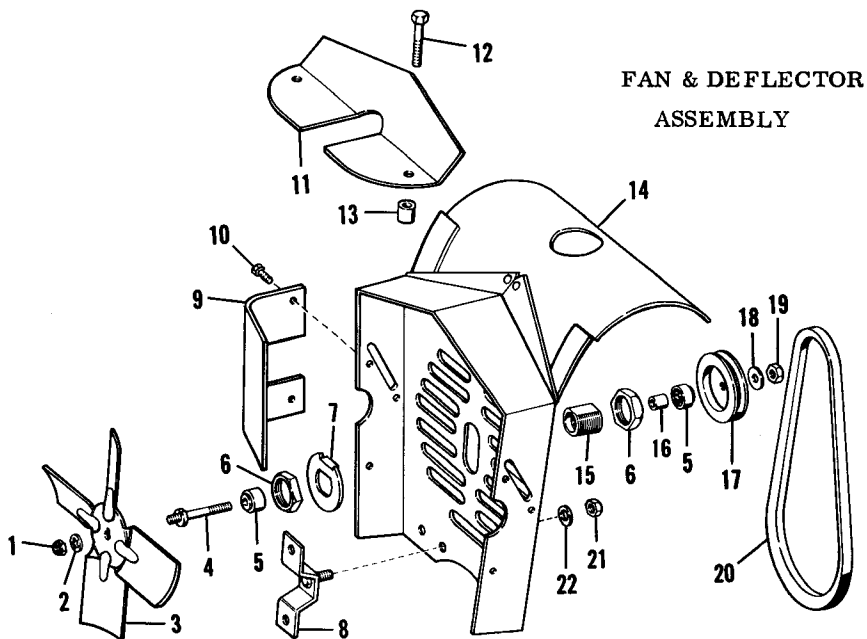

FAN & DEFLECTOR  
ASSEMBLY

Item No.	Part No.	Description	Quan. Req'd.	Price
1	206-N	Fan Securing Nut	1	\$ .02
2	305-W	Fan Nut Lock Washer	1	.01
3	L-805-AY	Fan Blade	1	1.27
4	5137	Fan Shaft	1	.56
5	5139	Fan Ball Bearing	2	2.09
6	5134	Fan Bearing Lock Nut	2	.32
7	L-830	Fan Retainer Adjusting Washer	1	.22
8	L-224	Fan Housing Bracket	2	.64
9	L-838-A-RH	Air Deflector, Right Hand	1	.50
	L-838-B-LH	Air Deflector, Left Hand	1	.50
10	156-S	Screws for L-838-A and B	4	.02
11	L-839	Cylinder Head Air Deflector	1	.66
12	155-S	Long Cylinder Head Screw	2	.06
13	L-840	Deflector Spacer	2	.09
14	L-222	Fan Housing	1	4.41
15	5133	Fan Bearing Race Retainer	1	1.33
16	5165	Fan Bearing Spacer	1	.08
17	L-802	Fan Pulley	1	.88
18	401-W	Fan Pulley Jam Nut Washer	1	.01
19	204-N	Fan Pulley Jam Nut	1	.02
20	5163	Fan Belt	1	1.18
21	205-N	Nut for L-224 Bracket	2	.03
22	403-W	Flat Washer for L-224 Bracket	2	.01



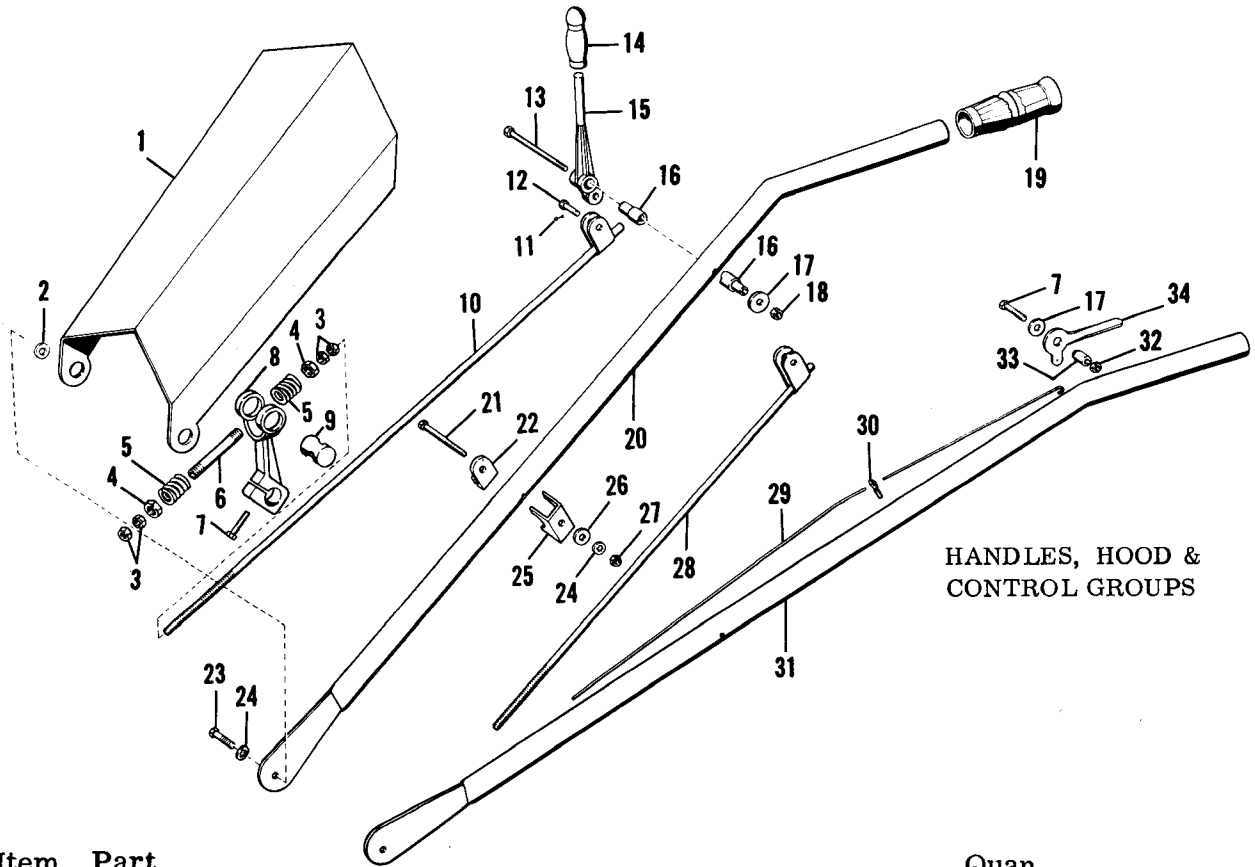

Item No.	Part No.	Description	Quan. Req'd.	Price
1	L-820	Hood	1	\$ 1.76
2	L-821	Hood Spacer Washer	2	.06
3	206-N	Clutch Rod Adjusting Nut	4	.02
4	210-N	Clutch Rod Sleeve Nut	2	.04
5	L-729	Spring	4	.14
6	L-730	Clutch Rod Sleeve	2	.31
7	<b>106-S</b>	Throttle Lever Pivot and Actuating Lever bolt	3	.06
8	L-715	Clutch Actuating Lever	2	1.29
9	L-723	Clutch Rod Pivot	2	.39
10	L-720-L	Clutch Rod - Long	1	1.09
11	602-C	Cotter Pin for L-722 Pin	2	.01
12	L-722	Clutch Rod Clevis Pin	2	.11
13	L-718	Hand Lever Pivot Bolt	1	.17
14	5167	Hand Lever Grip	2	.25
15	L-716	Clutch Hand Lever, or Speed Selector Lever	2	.79
16	L-717	Hand Lever Pivot	2	.28
17	<b>304-W</b>	Hand Lever Bolt Washer	2	.01
18	214-N	Hand Lever Pivot Bolt Nut	1	.02
19	L-725	Driving Handle Grip	2	.46
20	L-724-R	Driving Handle-Right	1	3.19
21	131-S	Driving Handle Bolt	2	.11
22	L-742	Clutch Rod Brace	1	.11
23	111-S	Driving Handle Securing Bolt	2	.07
24	305-W	Driving Handle Securing Bolt Lock Washer	2	.01
25	L-728	Driving Handle Bracket	2	.44
26	403-W	Driving Handle Bracket Bolt Flat Washer	2	.01

27	205-N	Driving Handle Bracket Nut	2	.03
28	L-720-S	Clutch Rod-short	1	1.05
29	L-737	Throttle Wire	1	.10
30	L-743	Throttle Stud	1	.10
31	L-724-L	Driving Handle-left	1	3.19
32	<b>214-N</b>	Pivot Bolt Nut	1	.02
33	L-744	Throttle Lever Nylon Washer	2	.10
34	L-740-A	Throttle Lever	1	.24

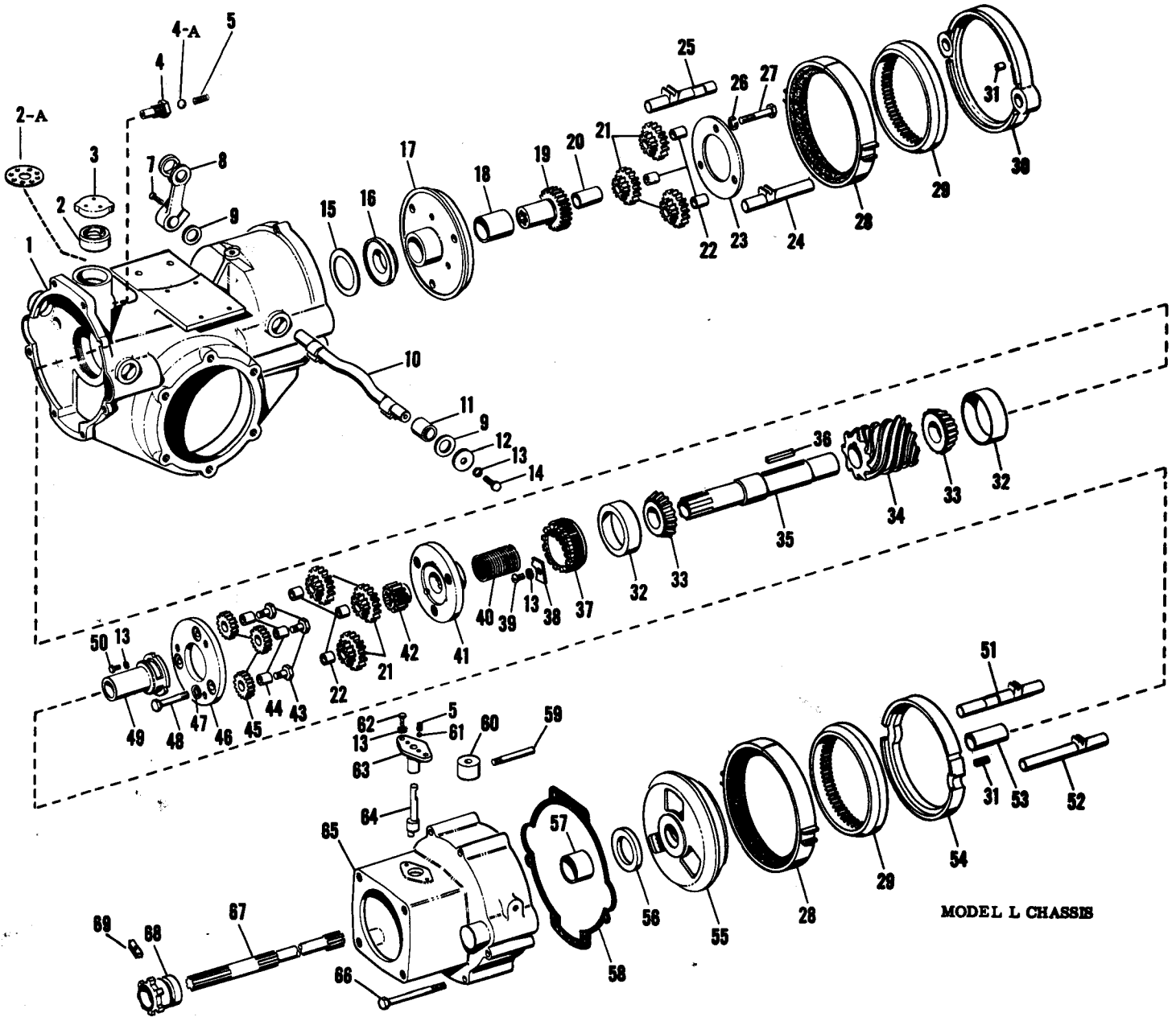

MODEL L CHASSIS

Photo No.	Part No.	Description	No. Req'd.	Price
1	L-201	Chassis Casting	1	\$ 37.60
2	L-211	Chassis Oil Filler Neck	1	.19
2-A	L-864	Filler Neck Baffle	1	.10
3	L-212	Chassis Oil Filler Cap	1	.78
4	L-856	Relief Valve Body	1	.67
4-A	L-865	Relief Valve Check Ball	1	.67

5	L-815-D	Spring .025"	2	.14
7	154-S	Actuating Lever Clamp Bolt	2	.06
8	L-715	Actuating Shaft Lever	2	1.29
9	L-735	Thrust Washer	1	.03
10	L-712	Clutch Actuating Shaft	2	2.87
11	L-713	Actuating Shaft Bushing	4	.24
12	L-736	Oil Seal Washer	2	.03
13	303-W	Quill Securing Bolt Washer	8	.01
14	165-S	Quill Securing Bolt	2	.02
15	2211	Rear Thrust Plate Shim (.020)	1	.07
16	L-519	Rear Thrust Plate	1	1.21
17	L-506	Rear Pin Plate	1	4.59
18	L-535	Rear Pin Plate Bushing	1	.56
19	L-511	Sun Gear	1	4.29
20	L-534	Sun Gear Bushing	1	.36
21	L-513	Orbit Gear	6	2.31
22	L-514	Orbit Gear Pin	6	.24
23	L-515	Pin Spacer	1	.42
24	L-711-R	Clutch Slide Rod, short	1	1.84
25	L-711-L	Clutch Slide Rod, short	1	1.84

**Clutch Slide Rods:** When ordering Clutch Cup (Part L-517) for Tractors manufactured earlier than 1956, it is necessary to also order the Clutch Slide Rods, Part L-710 (long) right and left for the front Clutch, or Part L-711 (short) right and left for the rear Clutch.

26	305-WL	Spacer Lockwasher	3	.02
27	L-516-L	Spacer Bolt Rear Pin Plate	3	.19
28	L-517	Clutch Cup	2	4.62
29	L-501	Internal Gear	2	3.93
30	L-524	Rear Spacer	1	5.39
31	HE-106	Roll Pin	2	.09
32	L-522-R	Worm Shaft Bearing Race	2	1.93
33	L-522-C	Worm Shaft Bearing Cone	2	3.03
34	L-601	Worm, Standard, (Specify 4, 6, or 8 lead)	1	9.08
35	L-521	Worm Shaft	1	4.53
36	L-608	Worm Key	1	.06
37	L-507	Bearing Adjusting Nut	1	1.53
38	L-523	Adjusting Nut Lock	1	.06
39	107-S	Lock Screw	1	.08
40	L-547	Pin Plate Spacer	1	.39
41	L-505	Front Pin Plate	1	3.70
42	L-510	Sun Pinion	1	1.32
43	L-542	Reverse Idler Bolt	3	.14
44	L-541	Reverse Idler Bushing	3	.15
45	L-540	Reverse Idler	5	1.49
46	L-539	Front Pin Spacer	1	3.04
47	305-W	Spacer Lockwasher	3	.01
48	L-516-R	Spacer Bolt Front Pin Plate	3	.19
49	L-536	Pin Plate Quill	1	4.29
50	191-S	Quill Securing Bolt	3	.03
51	L 710-L	Clutch Slide Rod, long	1	1.96
52	L 710-R	Clutch Slide Rod, long	1	1.96

53	L-546	Pinion Shaft Bearing	1	.44
54	L-508	Gear Cup	1	4.13
55	L-538	Reverse Cone	1	8.82
56	L-520	Front Thrust Plate	1	.88
57	L-532	Quill Bearing	1	.50
58	L-209	Chassis Front Gasket	1	.10
59	L-732	Shipper Shaft Lever	1	.13
60	L-733	Locator Body	1	.88
61	1809	Locator Ball	1	.02
62	164-S	Shipper Shaft Guide Bolt	2	.02
63	L-734	Shipper Shaft Guide	1	1.10
64	L-545	Shipper Shaft	1	1.32
65	L-202	Advance Casting	1	15.84
66	L-207	Advance Casting Bolt	6	.15
67	L-543	Pinion Shaft	1	4.95
68	L-544	Clutch Dog	1	2.70
69	L-226	Shifter Shaft	1	.35

MODEL "L" CHASSIS

ILLUSTRATION B 

Photo No.	Part No.	Description	No. Req'd.	Price
1	L-214	Oil Level Plug	1	\$ .50
2	L-822	Oil Strainer Body	1	1.21
3	L-823	Oil Strainer Nut	1	.45
4	204-N	Nut	4	.02
5	304-W	Bearing Cap Lockwasher	12	.01
6	L-205	Differential Housing	2	2.45
7	L-604	Bevel Gear	2	5.68
8	L-602	Worm Gear, (Specify 4, 6, or 8 lead)	1	18.98
9	L-607-K	Driving Block, (with keyway)	2	.50
10	L-603	Bevel Pinion	2	3.36
11	L-605	Pinion Pin	1	.98
12	501-K	Pinion Pin Key	1	.02
13	L-206	Differential Housing Bolt	4	.15
14	RB-111-C	Differential Bearing Cone	2	3.69
15	RB-111-R	Differential Bearing Race	2	2.26
16	L-220	Gasket (.005 22¢ .020 28¢)		
17	L-203-D	Axle Housing	2	7.98
18	L-213	Washer	1	.07
19	123-S	Axle Housing Drain Bolt (nylon plug)	1	.16
20	308-W	Lock Washer	11	.01
21	122-S	Axle Housing Bolt	11	.10
22	RB-110-R	Axle Bearing Race	4	1.38
23	RB-110-C	Axle Bearing (cone)	4	2.26
24	L-611	Axle	2	3.14
25	L-615	Axle Key	2	.06
26	L-219	Shim (as required .005 .020)		.11 ea .15 ea
27	L-204-D	Bearing Cap	2	1.49
28	L-221-A	Bearing Cap Oil Seal (double)	2	1.16
29	126-S	Bearing Cap Bolt	8	.06
30	227-N	Axle Nut	2	.23

MODEL L CHASSIS (CONT'D)

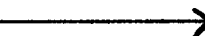