

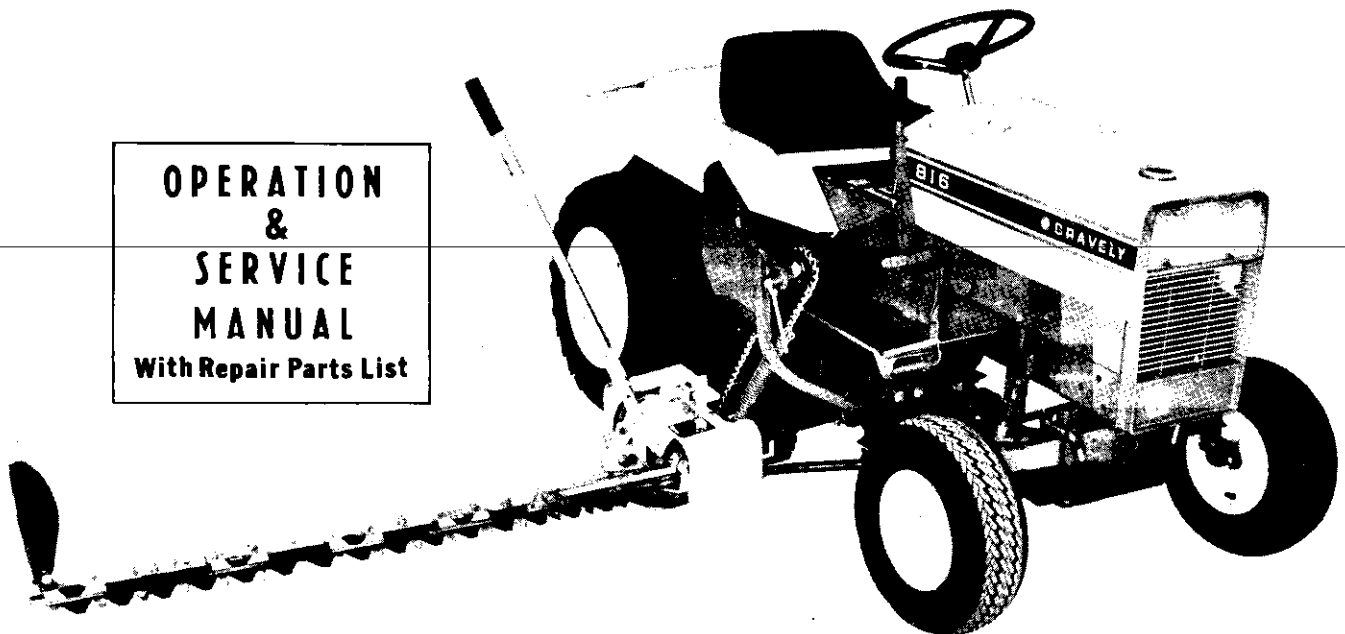

MODEL 413  
**SICKLE BAR MOWER**  
ATTACHMENT

 **GRAVELY**  
FOR 800 SERIES TRACTORS

**OPERATION  
&  
SERVICE  
MANUAL**  
With Repair Parts List



HABAN MANUFACTURING  
COMPANY

Racine, Wisconsin

Form 8662 (4/73)

Serial No. (199-805 - )



# GENERAL INFORMATION

Your Haban Sickle Bar Mower is the finest sickle bar mower available anywhere. Designed specifically for your compact tractor with all controls convenient to the operator, it's rugged construction assures you long life and highest performance. The mower cuts a 48" swath and operates from the tractor PTO.

Keep this manual available for ready reference. It has been carefully prepared to instruct you in operating, maintaining and lubricating your Haban Sickle Bar Mower. Emphasis has been placed on safety and operator protection. However, careless and negligent operation can still result in serious injury to persons and property. It is very important that each operator fully understands the contents of this manual for safe dependable operation and to prolong the life of the equipment.

When in need of parts, be prepared to give your dealer the serial numbers shown on the mower nameplate located on the frame. Write the serial number in the blank shown.

HABAN MODEL 413 SICKLE BAR MOWER  
SERIAL NO. \_\_\_\_\_

## OPERATING TRACTORS WITH HYDROSTATIC OR GEAR TYPE TRANSMISSIONS

Best cutting results will be obtained by operating tractor at 3/4 to full engine speed. With hydrostatic transmission adjust tractor ground speed through hydrostatic control pedal. With gear type transmissions regulate tractor ground speed by selecting proper gear ratio, usually second or third gear.

Mowing in extremely rough areas requires reduction in tractor speed.

When cutting brush larger than 1/2" diameter, slow forward speed of tractor prior to cutting brush. It may be necessary to stop tractor movement when sickle bar makes contact and allow the sickle knife to cut through the brush material. It is not recommended to attempt to cut material exceeding 1-1/2 to 2" in diameter.

Performance of the sickle knife depends on the following points, all of which are important: (1) sharpness of sickle knife; (2) wear plate adjustment; (3) straightness of knife bar; (4) hold-down clip clearance; (5) speed of sickle knife; (6) lead adjustment of sickle bar; (7) cutting pitch of shear fingers.

## TRANSPORT POSITION:

The sickle bar mower can be transported from one location to another by raising the unit with the lift handle and locking it into position as illustrated on page 5.

**▲ ALWAYS INSTALL KNIFE GUARD ON MOWER BAR WHEN TRANSPORTING.**

**▲ ALWAYS OPERATE AT CAREFUL SPEEDS IN TRANSPORTING AND AVOID MAKING SUDDEN OR SHARP TURNS WITH THE MOWER IN RAISED POSITION.**

## CONTENTS

SAFETY.....	3 & 18
OPERATION.....	4-10
TRANSPORTING MOWER.....	5
ADJUSTMENTS	
V-Belts.....	7
Sickle Knife.....	8
OPERATING MOWER.....	9-10
SERVICE TIPS.....	10
MAINTENANCE.....	11
SET UP.....	12-18
PARTS LISTING.....	19-23

## SPECIFICATIONS

Length.....	73"
Clearance Required.....	3"
Cutting Width.....	Mows 48" Swath
Overall Depth.....	24"
Drive.....	Belt Driven from Tractor P.T.O.
Clutch.....	Belt Type
Suspension.....	Free-Floating, Spring Suspended
Mounting.....	Swivel, Vibration-Dampening
Cutting Speed.....	900-1100 strokes per minute
Stroke.....	Full 3" width
Shear Knives.....	High Carbon Steel
Guards.....	non-clogging
Vertical Adjustment.....	135°—45° below horizontal 90° vertical—lever controlled
Transport Position.....	Pin-Locked for Transport
.....	Automatic Spring-Loaded "Swing Back" device protects against damage from solid objects
Construction.....	All-Steel, with Anti-Friction bearings

# OPERATION

For starting or stopping your Sickle Bar Mower. Refer to tractor instruction manual on proper method of clutching and declutching attachments used with tractor.

NEVER leave the tractor engine running when dismounting from the tractor. De-clutch front tractor P.T.O. clutch as well.

Always stop tractor engine when dismounting from tractor set parking brake or place tractor transmission in park position. Always de-clutch front P.T.O. whenever stopping tractor engine or tractor operation.

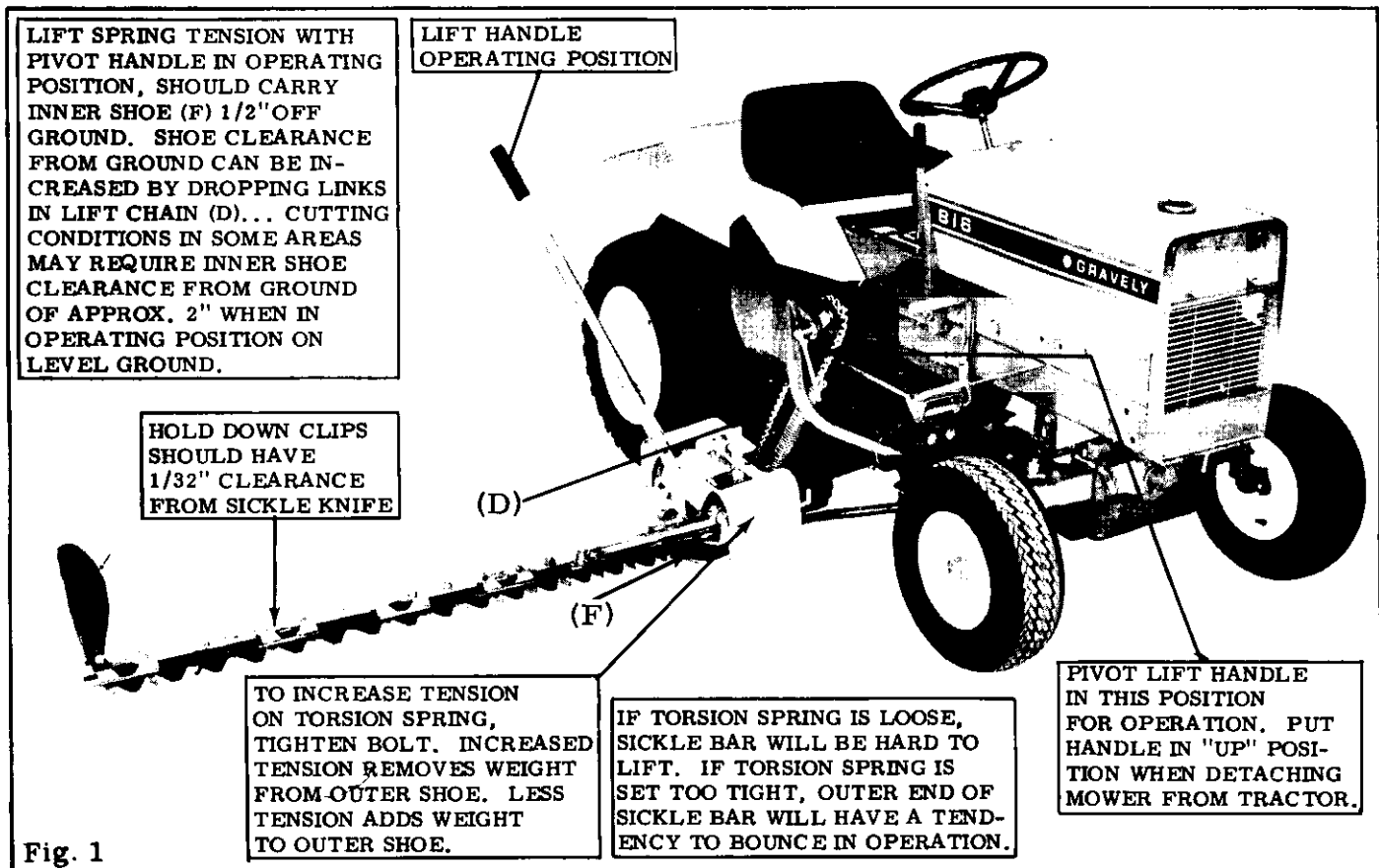
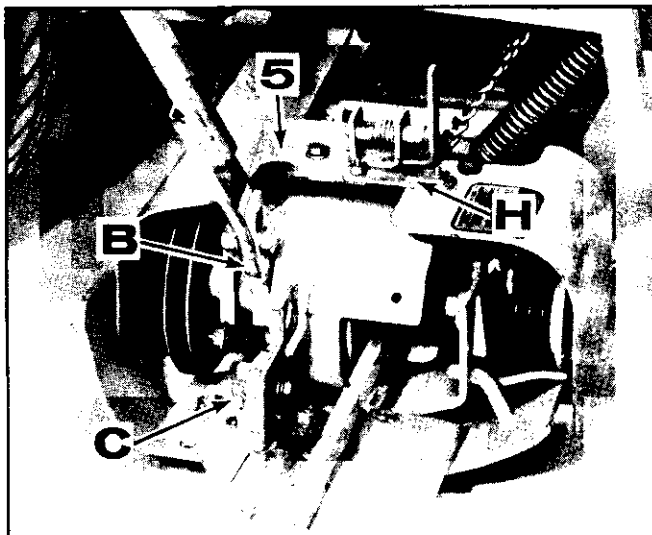

Fig. 1

Fig. 2 ▲ Keep lock strap (H) in place.



**LIMIT STOP (Figure 2) NORMAL CUTTING:** The limit stop (5) should be set with LOCK OUT STRAP (H) in place on slot. This will limit the travel of the Cutter Bar in cutting position to approximately 70° above ground level and allow it to function to its maximum below ground level. The lift arm must always be set in operating position (B) when cutting.

**VERTICAL CUTTING (90° only)** The lockout strap (H) must be removed to cut 90° above ground level or vertical. When finished with vertical cutting, bolt strap (H) back in place. The lift arm must always be set in operating position (C) when vertical cutting.

**CAUTION:** Make sure lock out strap (H) is bolted securely in place when finished with vertical cuttings.

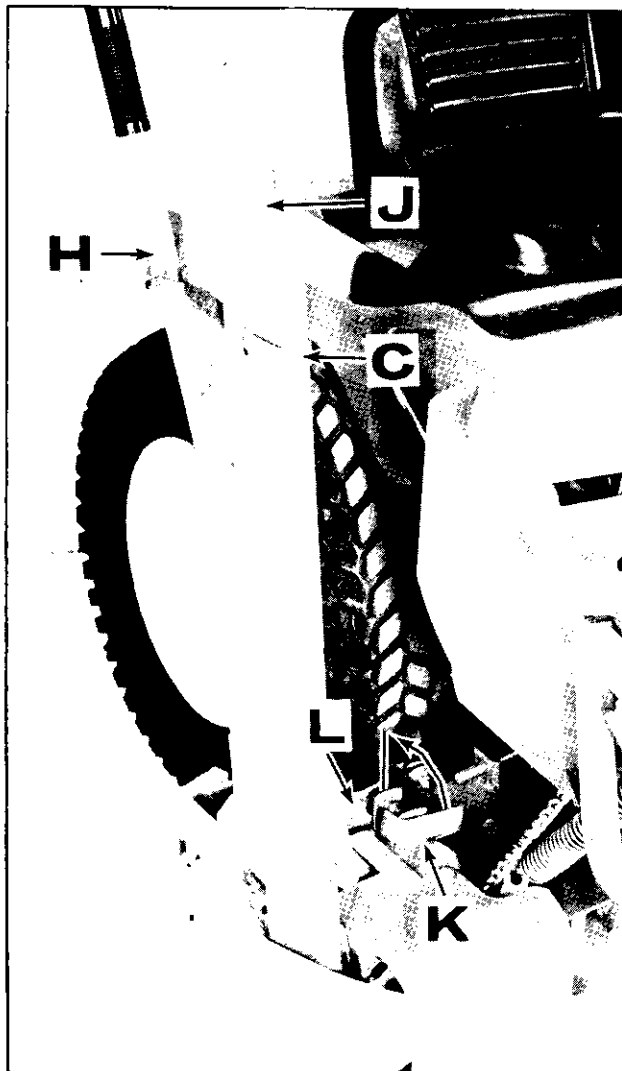

Fig. 3

## TRANSPORTING MOWER:

Stop tractor engine and disengage tractor P.T.O. clutch. Install sickle knife cover (J) using retaining strap to secure cover to bar. Set lift handle in transport position (H). Stand in back of mower, raising mower bar with right hand to vertical position. Insert transport pin (K) as illustrated by sliding pin down from vertical to horizontal position as shown. Let pin slide through hole in strap (L) to lock in place. Avoid sudden or sharp turns with mower in transport position (Fig. 3).

## TO CHANGE SICKLE BAR MOWER FROM TRANSPORT POSITION TO MOWING POSITION:

Stop tractor engine. Standing behind mower push inward on mower bar, slide transport pin (K) out of strap (L) and turn strap to vertical position to lock out. Lower sickle bar to ground. Loosen retaining strap (C) and remove sickle knife guard. Always install sickle knife guard when mower is not in use or when transporting unit.

## WHEN CUTTING ON LEVEL GROUND

Before operation, check complete unit for any looseness which may have occurred in shipping. Unit should then be operated a short period to check for proper assembly and adjustments before actual cutting begins. Stop and recheck all parts after 30 minutes of operation and retighten loose parts. Also follow lubricating instructions found on page 11. Operate tractor at full throttle. It will be necessary to regulate tractor forward travel to meet existing cutting conditions, which can vary greatly, depending on material that is being cut. RUN INNER SHOE APPROXIMATELY 4" AWAY FROM PREVIOUS SWATH EDGE FOR BEST PERFORMANCE. Cutter bar has additional width of cut to compensate for overlay. Care must be exercised not to operate tractor at excessive ground speed when cutting rough terrain. The lift arm must always be set in operating position (B) when cutting.

Under severe conditions the sickle knives should be sharpened after every four hours of operation. Additional knives and rivets are available for repairs, which makes it possible to always have a sickle knife assembly in good repair if one becomes damaged or worn.

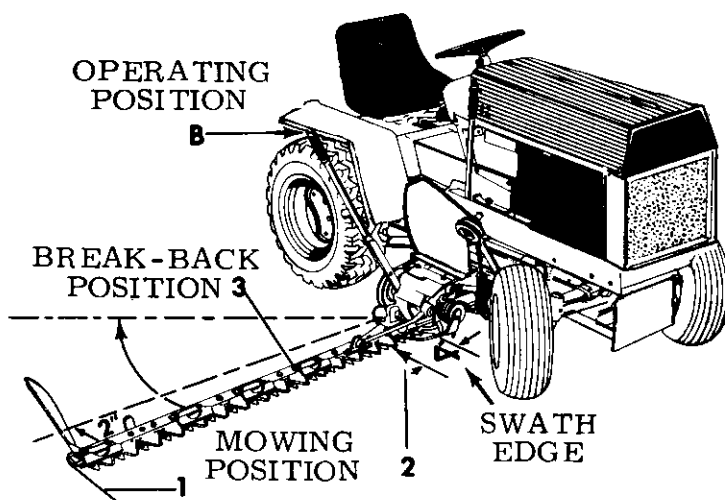

Fig. 4

# OPERATION

## CUTTING (90° Vertical to 45° above level)

When cutting 90 degree vertical to 45 degree above level, the engine throttle should be set approximately 1/8" open. The lift handle must be set in transport position. (A). (Fig. 5).

**▲ NOTE:** This should be done by an experienced operator only, using extreme caution.

Fig. 5

VERTICAL CUTTING  
OR  
TRANSPORT POSITION

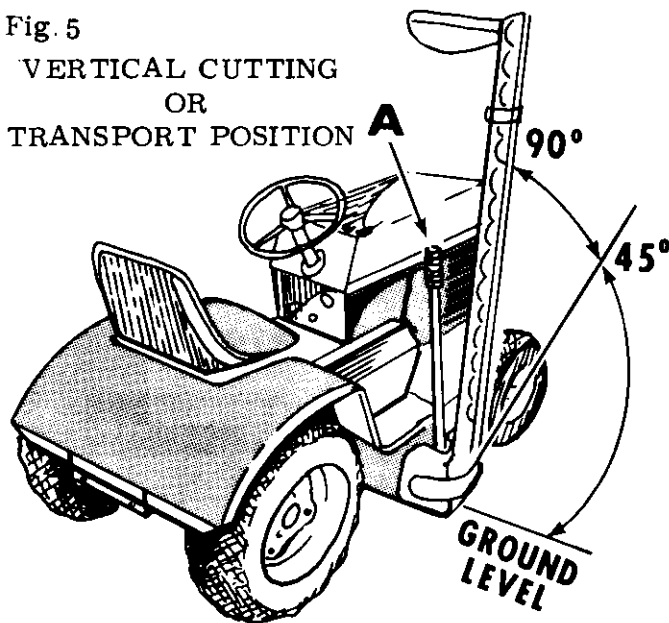
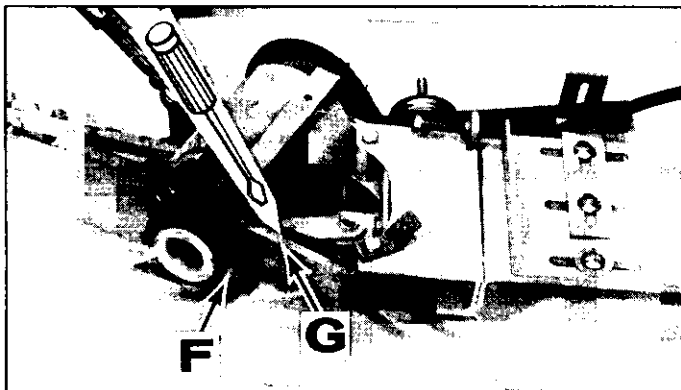

Fig. 6



## AUTOMATIC BREAK-BACK (Figure 6)

The break-back automatically releases sickle bar into break-back position when hitting obstruction. The sickle-mower unit should be immediately DE-CLUTCHED. Return sickle bar to normal cutting position, engaging break-back. This may be done by reversing tractor with sickle bar on ground, or manually. Unwarranted or frequent break-back releases indicate tension on the spring (F) should be increased.

To disengage safety break-back manually, insert screw driver at (G) and pry break-back pivot open-at same time push sickle bar back to release catch. Fig. 6.

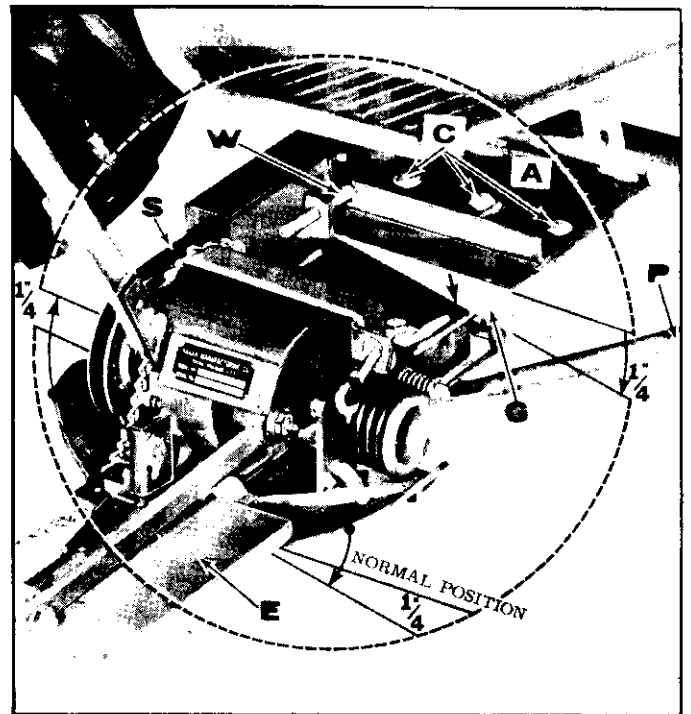

Fig. 7

## KNIFE POINT POSITION (Pitch Angle (Fig. 7))

To adjust pitch of sickle bar (E), loosen bolts (G) and bolts in tie rod (P). Install sickle knife guard and raise sickle bar to vertical position. Push forward to increase downward pitch of sickle bar. Normally sickle bar (E) should have a downward pitch of about 1/4" from carriage plate (A), Fig. 7. When cutting extremely heavy, tangled or matted grass, it may be necessary to increase downward pitch of sickle bar. After desired setting is reached retighten bolts (G) and bolts in tie rod (P).

## OPERATING POSITION

Fig. 8

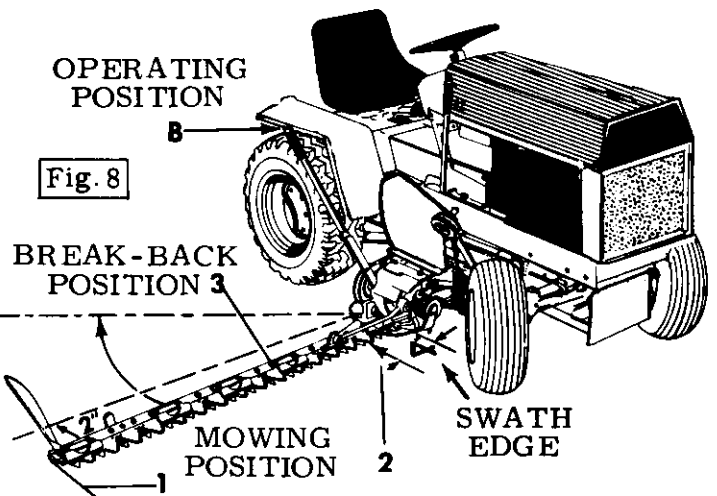

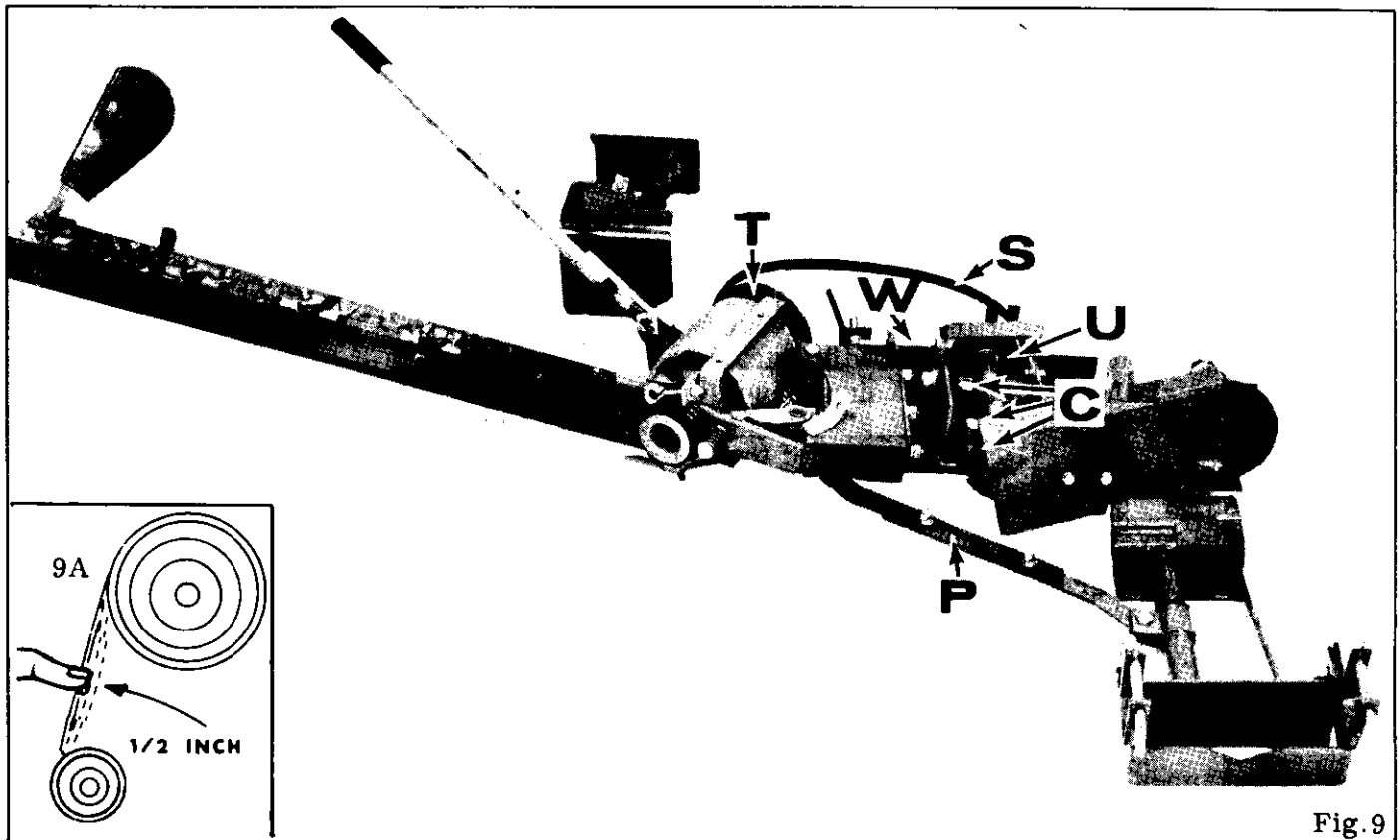

Fig. 9

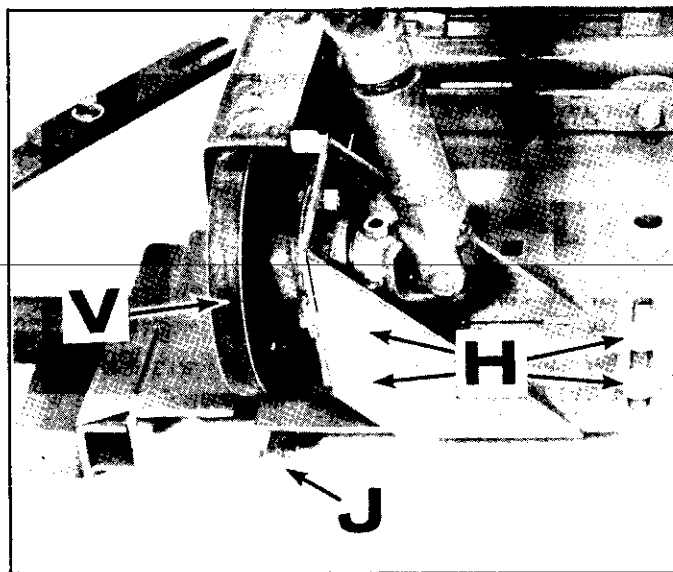

Fig. 10

### ADJUSTMENT OF PITMAN AND MOWER DRIVE BELTS.

If additional tension is needed on Pitman drive belt (S), loosen bolts (C) and bolts in tie rod (P). Loosen jam nut on adjusting bolt (W) and turn adjusting bolt until V-belt (S) is tightened. (Proper tension will allow approximately 1/2" deflection of V-belt when applying firm finger pressure midway between pulleys). Tighten jam nut on adjusting bolt and secure bolts (C) and bolts in tie rod.

If additional tension is needed on drive belt (V), Fig. (10), loosen four bolts (H) and jam nut on adjusting bolt (J). Turn adjusting bolt until proper tension is obtained. Retighten jam nut and four bolts (H).

### SETTING LEAD OF SICKLE BAR

(Fig. 8) Improper lead adjustment of sickle bar assembly will create excessive side draft on tractor and poor cutting action, as well as possibly plugging sickle knife. Outer end of sickle bar at (1) should lead inner end (2) by two inches as illustrated in (Fig. 8). To adjust lead, loosen three vertical bolts (C) in plate (A) and two set screws in tie rod (P) (Fig. 9). Adjust cutter bar (3) to lead setting as illustrated in (Fig. 8), by pushing outer end of bar forward. Slots in carriage plate (A) will adjust accordingly to allow for change in lead setting. (Fig. 9). When proper setting is obtained tighten vertical bolts (C) and two set screws in tie rod (P). **IMPORTANT:** Proper V-belt tension will allow approximately 1/2" deflection of V-belt when applying firm finger pressure midway between pulleys (Fig. 9a).

# OPERATION

## Sickle Knife Adjustment

Check the position of the forward ends of the live knife sections (B) to make sure that they protrude past the forward ends of the shear finger plates (E). For cutting loose pre-cut hay, dense, fine and loose under growths, etc., without clogging, the live moving knives must contact the material ahead of any stationary shear-plate.  $1/32''$  to  $1/16''$  protrusion of the knife is sufficient. If your "wear-plates" (A) are worn half way thru on the front edge, moving the wear plate forward will place the sickle in the proper position. If the wear plate is worn too much for making the proper adjustment they should be replaced.

### KNIFE ASSEMBLY REMOVAL

When it becomes necessary to remove the knife for sharpening, section replacement or complete knife replacement, remove the bolts holding the knife head to bar and slide knife out of guard assembly.

### ALIGNMENT OF LEDGER PLATE SURFACES

Remove the knife assembly and check all shear fingers for alignment of surfaces. The alignment may be checked by using a straight edge or drawing a string tightly across these surfaces. Any shear finger being too high will create excess clearance between the shear finger and the knife sections. Misalignment can be corrected by bending shear fingers up or down, as required. Hammer only on solid portion of guard beyond the lip.

### WEAR PLATE ADJUSTMENT (Fig. 10)

The wear plates (A) support the back of the knife sections (B) and guide the knife bar in the shear finger recess. Wear plates have elongated holes for adjustment against the knife bar (C) to prevent it from drifting forward and backward. Adjust by loosening the guard bolts (D) and sliding the wear plate forward against the knife bar. Avoid a tight fit. Check the top surface of the wear plate with the shear finger surface (E). These two surfaces must be even. A low wear plate should be shimmed.

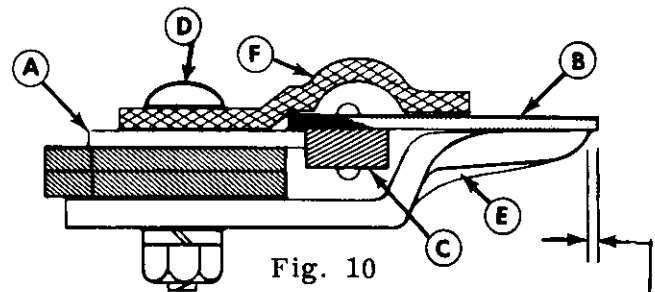

LIVE SICKLE SECTIONS TO PROTRUDE  $1/32''$  to  $1/16''$  OVER SHEAR PLATE.

### KNIFE CLEARANCE (Fig. 10)

If the knife fits too loosely, in most cases clearance can be obtained by hammering down or prying up the front end of the hold down clips (F). The suggested method is to remove the knife assembly. Reinsert the knife and adjust each clip as it is reached, for the entire length of the bar. Bend each clip up or down as required. The approximate clearance to be maintained should not exceed  $1/32''$ . Fitting these clips too tightly will cause binding or scoring, excessive vibration and chatter. Lubricate freely.

### CUTTING FAILURE

#### A. Check sharpness of knife sections.

1. If sharpening is necessary a sickle grinder with a holder should be used for this operation to maintain correct grinding angle. (Same as original)
2. Replace damaged sections.

#### B. Check fit of knife sections to shear fingers and wear plates. If the knife sections are sharp, clean cutting is entirely dependent upon the following:

1. Alignment of shear finger surfaces.
2. Wear plate adjustment.
3. Straightness of knife bar.
4. Pitch of shear fingers.
5. Hold down clip clearance.
6. Proper lead setting of mower.
7. Improper speed of sickle knife in relation to forward travel of tractor.

Be sure the sickle sections are sharp at all times and held close to the shear fingers by the sickle slips. Be careful, however, of having them too tight as this will cause binding. Always lubricate well with oil at the point on the bar and shear finger assembly where the clips contact the knife assembly.

## OPERATING THE MOWER:

### PRESTARTING INSPECTION:

1. Be sure mower has been properly assembled to tractor. Set-up instructions start on page 12.
2. Be sure mower is properly adjusted.
3. Check condition of sickle sections. Keep them sharp.

With tractor engine throttle set just above idle, engage front tractor P.T.O. clutch. Always advance throttle to full position when mowing on level ground.

### STOPPING THE MOWER:

Refer to your tractor manual for starting and stopping tractor attachments.

### METHOD OF MOWING:

Before mowing a new plot of grass, always stop to analyze the area for best mowing procedure. Consider also the height of grass to be mowed, type of terrain (level, hilly or pitted), as well as the presence of rock or trash. Each condition will require certain adjustments or precautions, as outlined in the following pages.

**▲ CAUTION:** Before servicing machine, disengage power, stop engine, and disconnect engine spark plug cable.

**▲ CAUTION:** Pick up all rocks, stones and other debris you can find before mowing in a new area. Enter the area cautiously.

Sickle bar mower can operate from 90 degree vertical to 45 degree below horizontal. It may be necessary to release some tension on the torsion spring to allow mower bar to drop to lowest angle. There should be a 1/32" clearance between sickle sections and hold down clips. If several years of dead grass has accumulated in areas being cut, particularly on hills or slopes, it may be necessary to cut against the slope due to dead material leaning forward, thereby not allowing the sickle to cut cleanly.

Test pattern cutting will soon show you the most appropriate way to approach the task. Remember, the proper settings, a sharp sickle, correct forward speed, and good general maintenance will enable you to cut any reasonable patch of grass with satisfaction. Overlooking any one of the above points may detract from the machine's performance. A few points are listed below:

### OPERATING SICKLE BAR MOWER ON TRACTORS WITH HYDROSTATIC DRIVE:

Proper ground speed for mowing depends upon (1) the height, density, and type of grass to be cut and (2) field or yard conditions. When mowing, always operate engine at full throttle. This is necessary to maintain proper sickle speed and to cause maximum flow of air to cool engine.

Operation of hydrostatic drive tractors enable you to easily obtain the proper ground speed needed for best mowing performance with the sickle bar mower. A short amount of testing when starting to mow in the various conditions that you find, will enable you to determine the most appropriate speed for that particular condition. Too fast a forward ground speed will cause problems as outlined in paragraph three as listed in operating tips (page 10).

Exceptionally tall grass or weeds, uneven terrain, may require you to operate your tractor at a much slower speed than you would normally use. On the other hand sparse weeds etc., may enable you to operate at a higher rate of forward speed than would normally be used under regular cutting conditions.

### GEAR TYPE TRANSMISSIONS

Generally, best mowing will result when operating the tractor shift lever in second or third gear and engine operating at full throttle. Tall grass or weeds may require you to operate in first gear in some conditions.



# OPERATION

## REMEMBER SAFETY PAYS.

Always slow down the forward speed of the tractor at the time of making a sharp turn, cutting on a radius, on banks or slopes or other uneven terrain.

**CAUTION:** When mowing over rough ground or on hillsides, the hydrostatic transmission allows selection of safe ground speed at full engine throttle.

## \* SERVICE TIPS

PROBLEM	SOLUTION
1. Cutter bar outer shoe bounces or digs into ground surface.	Adjust torsion spring as indicated in figure 1, (Page 4).
2. Inner shoe dragging on ground.	Raise inner shoe assembly by adjustment of lift spring (Fig. 1, page 4). Make sure lift chain is properly assembled.
3. Mower does not cut cleanly, drags hay under sickle, cutting pattern shows blank or skipping points.	Adjust forward travel of speed to coincide with sickle knife action. Check setting of hold down clips (Page 8). Check lead setting (See page 7).
4. Bunching of cut material in front of inner shoe after adjustment of lift spring.	Inner shoe is being run too close to edge of previous swath. Allow approximately 4" overlap. Fig. 4 (Page 5)
5. Failure to cut grass and weeds.	Check clearance of sickle to guards - fit should be snug, 1/32" clearance. Tap metal hold-down clips with hammer to adjust. Sharpen sickle section if dull. Check pitch of guards and lead of sickle bar.

## OPERATION

### SERVICE TIPS FOR SICKLE BAR MOWER OPERATION WITH HYDROSTATIC DRIVE TRACTORS:

Operation of hydrostatic drive tractors enables a wide variance of forward speed at a single throttle setting without necessarily taking into consideration the type of material that is being cut. Listed below are some of the tell-tale signs which will indicate when you are operating your tractor in excess of reasonable performing speeds:

1. Jagged or uneven cutting indicates too fast a forward ground speed.
2. Plugging sickle assembly could be created by either excessive forward speed, improper lead adjustments, improperly installed hold down clips, dull sickle or incorrect pitch angle of sickle bar.

Cutting of heavy, short undergrowth, intermingled with tall weeds may require a slower forward speed than would normally be used for weed mowing. Be certain that your sickle assembly is always kept sharp.

**CAUTION:** Never attempt to force the sickle bar mower to raise, if the outer end of the bar is lodged or caught in foreign debris, dirt or heavy underbrush. Give your tractor and the equipment every possible opportunity to operate efficiently. Attempt to reverse tractor or move forward carefully until sickle bar is released from entanglement or -- stop engine -- set parking brake - disengage PTO clutch, dismount from tractor and release mower bar from entanglement manually, then proceed.

Remember, always keep engine running at full throttle when mowing - regulate forward speed through hydrostatic transmission control.

Zerk fittings should be greased with regular pressure gun lube.

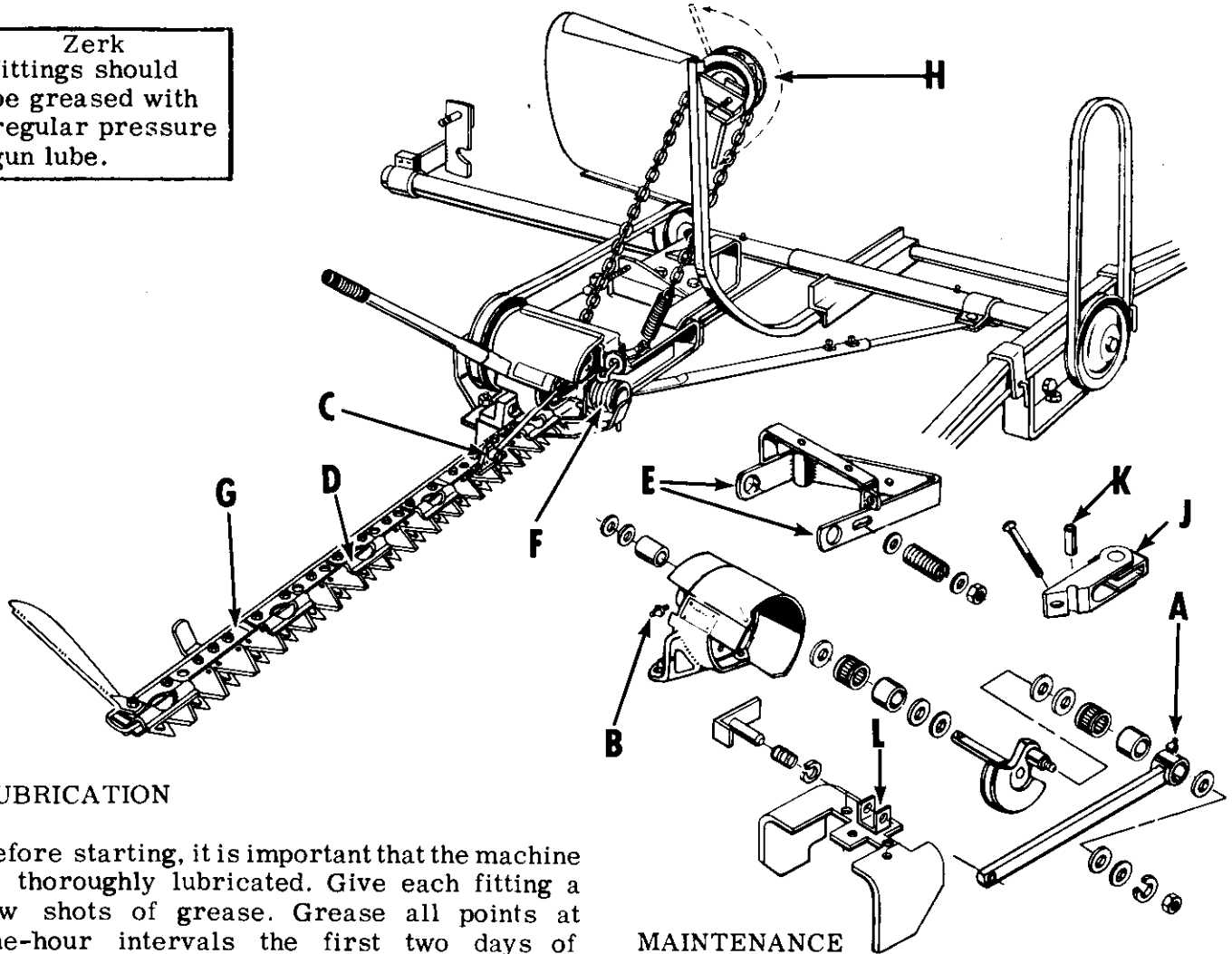

## LUBRICATION

Before starting, it is important that the machine is thoroughly lubricated. Give each fitting a few shots of grease. Grease all points at one-hour intervals the first two days of operation and then twice each day thereafter. Entire unit should be greased at least once each four hours during continuous operation.

The following fittings require grease every four hours of machine operation:

- (A) Pitman crank pin
- (B) Crankshaft

The following points require oil can lubrication as shown:

- Every two hours
  - (C). Pitman head
  - (D). Sickle clips
  - (G). Wear plate and moving points
- Every eight hours
  - (E). Two inner shoe pivots
  - (F). Torsional lift spring
  - (H). Transport spring pulley
  - (J). Spring release pivot assembly
  - (K). Spacer break away housing
  - (L). Quick pin assembly

## MAINTENANCE

Adjust the belt tension described under "Belt Adjusting" on pages 7 and 14. Proper tension allows for approximately one-half inch deflection when finger pressure is applied midway between pulleys. Check V-belt for wear. Replace worn belts with belts supplied only by Haban.

## CLEANING

**⚠ CAUTION:** Before servicing machine, disengage power, stop engine, and disconnect engine spark plug cable.

For best and lasting results, the machine should have all dirt accumulations removed from sickle bar. Do not allow machine to stand for long periods without cleaning. Inside storage will also prolong its operating expectations.

# SET UP

Your sickle bar attachment and all necessary parts and hardware are packed in two cartons. Unpack cartons carefully to insure that all parts are accounted for. Lay out all assemblies in the position as shown (Fig. 12).

The Sickle Bar Mower consists of the following:

## MOWER CARTON

A-Basic Mower Assembly

## CARTON OF MOUNTING PARTS

B-Main Frame

C-Carriage Plate Assembly

D-Rear Hitch

E-Rear Hanger Assembly

F-Carrier Arm Assembly

G-V-belt Guard

H-Lift Arm Extension

J-Grass Divider Board

K-Bag of Parts

## Bag of Parts

GM-120378	Nut	1/2-13 Lt. Hex	7
GM-120389	Washer	1/2 Flat (1/2 x 1-1/4)	2
GM-120384	Washer	1/2 Med. Lock	5
3554	Spacer	Breakaway Housing	2
GM-180190	Bolt	1/2-13 x 3 Hex Hd	1
GM-180192	Bolt	1/2-13 x 3-1/2 Hex	1
6073	Anchor	Spring	1
GM-120915	Bolt	3/8-16 x 1 Carriage	1
9142	Washer	Guard	1
GM-120388	Washer	3/8 Flat (7/16 x 1)	1
GM-271190	Nut	Nut & Lock Washer	1
GM-126499	Bolt	1/2-13 x 1-3/4	3
3341	Pin	Hair Cotter	2
9067	V-Belt	B-43	1
3434	Spring	Transport	1
8243	Strap	Locator	1

Fig. 12

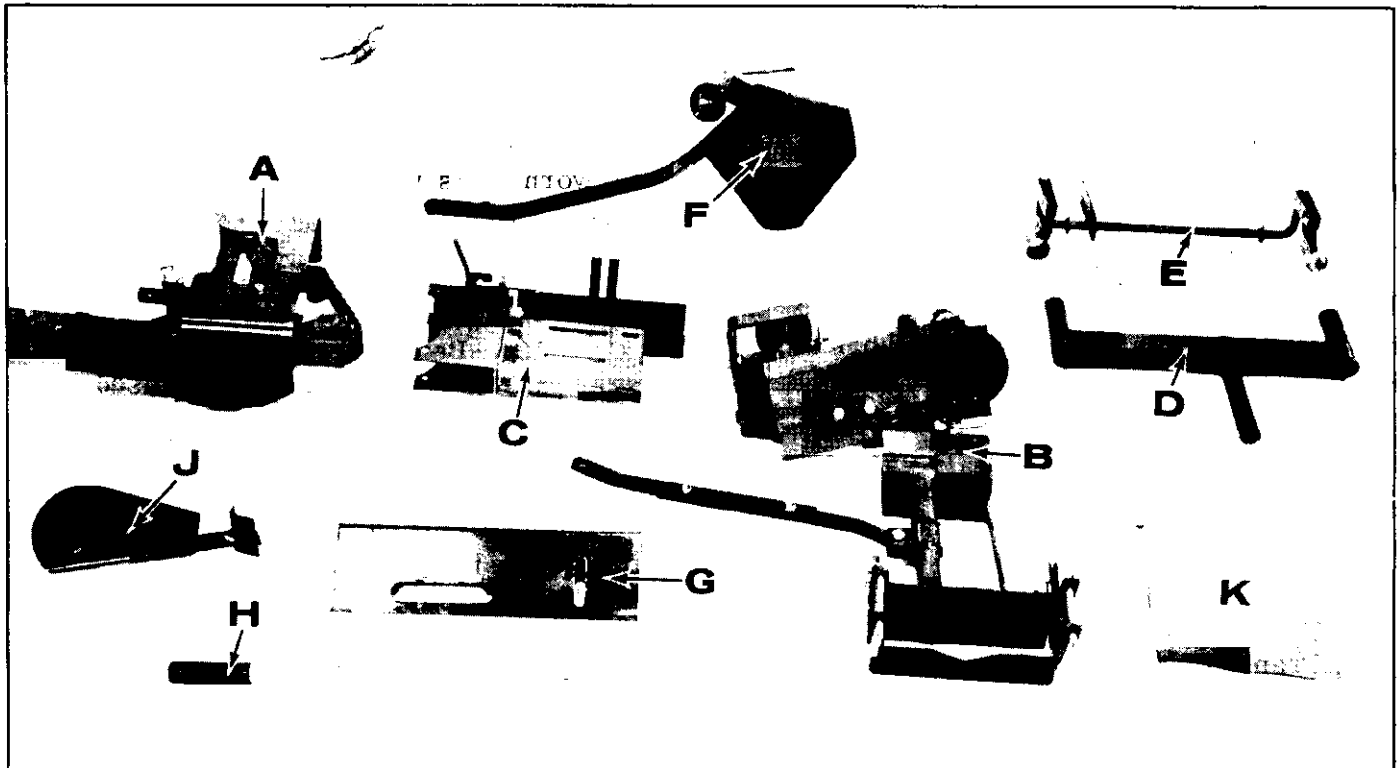

## SICKLE BAR ASSEMBLY (Fig. 13)

Remove plastic ratchet strap holding jackshaft to main frame support plate (C). Place carriage plate (B) beneath main frame support plate, with vertical plate of (C) against adjusting bolt (A). Align slotted holes. Insert three 1-1/2 x 1-3/4 carriage bolts down through jackshaft straps, slotted holes in plates (B) and (C) and support brace (F). Place lock washer and nuts on bolts and finger tighten only.

To attach the sickle bar breakaway latch frame assembly (H) to the breakaway housing (B), insert spacer (J) into breakaway latch frame hole (K). With the spacer in place, align hole (K) with hole (L) in breakaway housing plate (B) and insert 1/2" x 3" hex. head bolt. Secure with lock washer and nut in (Fig. 13).

GRASS DIVIDER BOARD (J) goes on the end of sickle bar. Remove hex. nut and place grass divider (J) over carriage bolt and secure with hex. nut (Fig. 12).

NOTE: Torsion spring (J) should not be attached to torsion adjusting bolt (K) at this point (Fig. 15).

Fig. 13

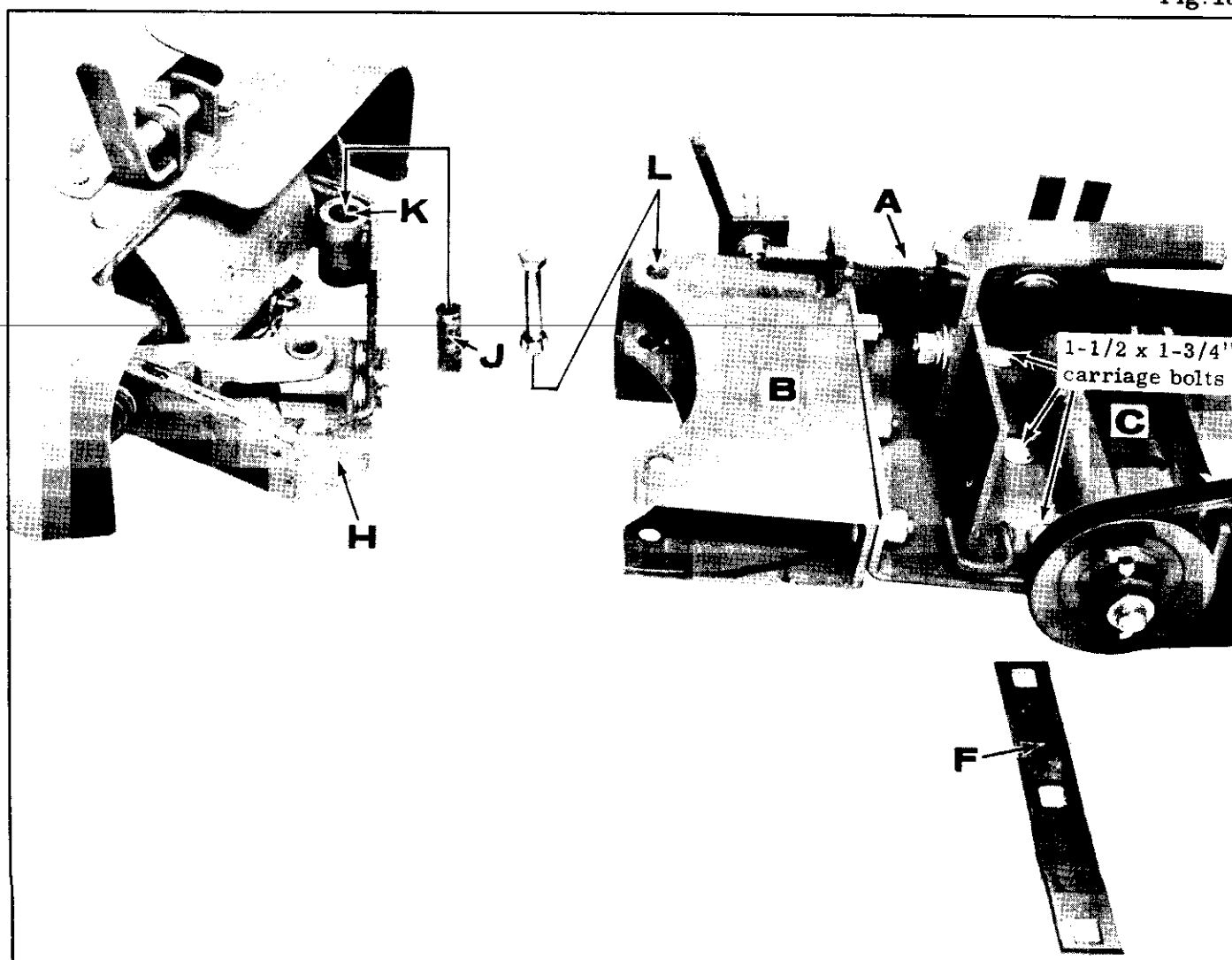

# SET UP

Fig. 14

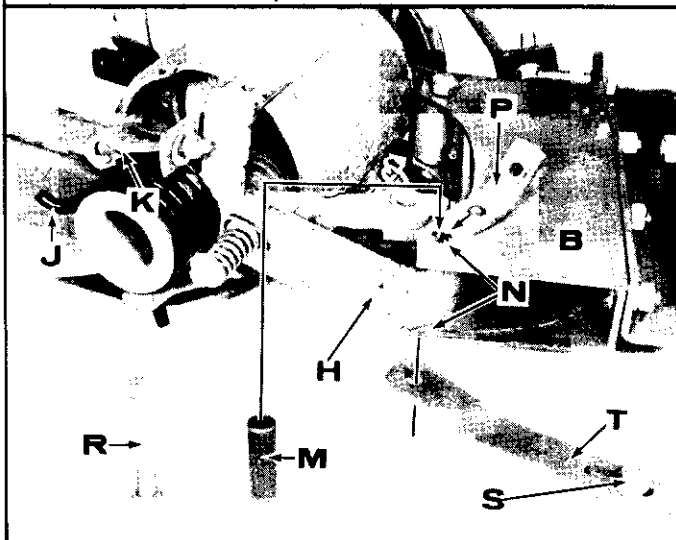
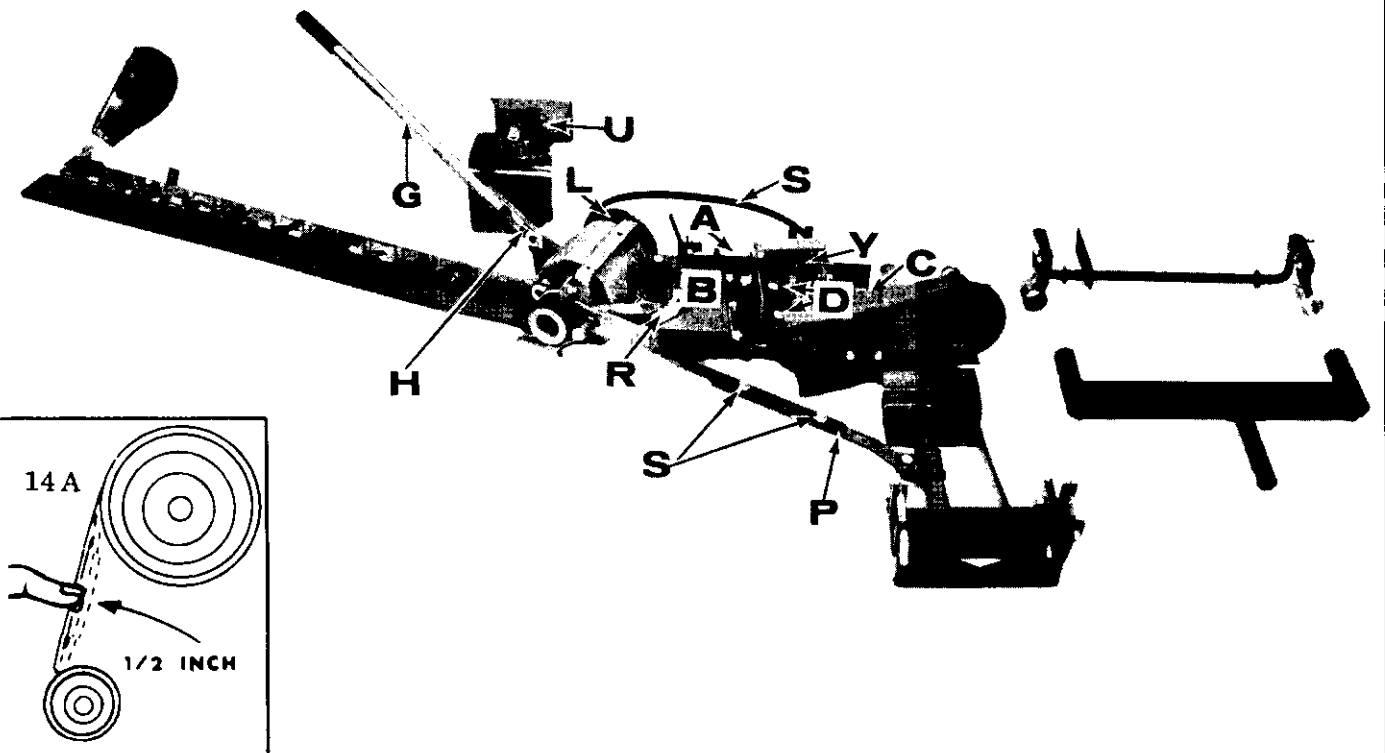

Fig. 15

Swing latch frame (H) into breakaway housing (B) as shown (Fig. 15). Place and align spacer (M) between two holes (N) in breakaway housing. Place angle clip (P) over hole (N). Keep angle clip in the position as shown (Fig. 15). Thread 1/2" x 3 1/2" hex. bolt (R) down through hole (N). Loosen set screws (S) in tie rod (T); adjust tie rod to align with bolt. Keep lock washer and hex. nut loose at this point.

## V-BELT INSTALLATION

Leaving mower assembly in break-back position, install V-belt (S) as follows: Remove housing stop cover (U). Slide V-belt onto pulleys (Y) and around crank-shaft pulley (L) as shown.

Align assemblies (B) and (C) so they are evenly together, then tighten bolts (D) and reset anchor bolt (A) to touch end of carriage plate as shown (Fig. 14). Retighten set screws (S) in tie rod.

## ADJUSTMENT OF PITMAN AND MOWER DRIVE BELTS

If additional tension is needed on Pitman drive belt (S), loosen bolts (D) and bolts in tie rod (P). Loosen jam nut on adjusting bolt (A) and turn adjusting bolt until V-belt (S) is tightened. (Proper tension will allow approximately 1/2" deflection of V-belt when applying firm finger pressure midway between pulleys). Tighten jam nut on adjusting bolt (A) and bolts (D) and bolts in tie rod.

If additional tension is needed on drive belt (V), Fig. (16), loosen four bolts (H) and jam nut on adjusting bolt (J). Turn adjusting bolt until proper tension is obtained. Retighten jam nut and four bolts (H).

Fig. 16

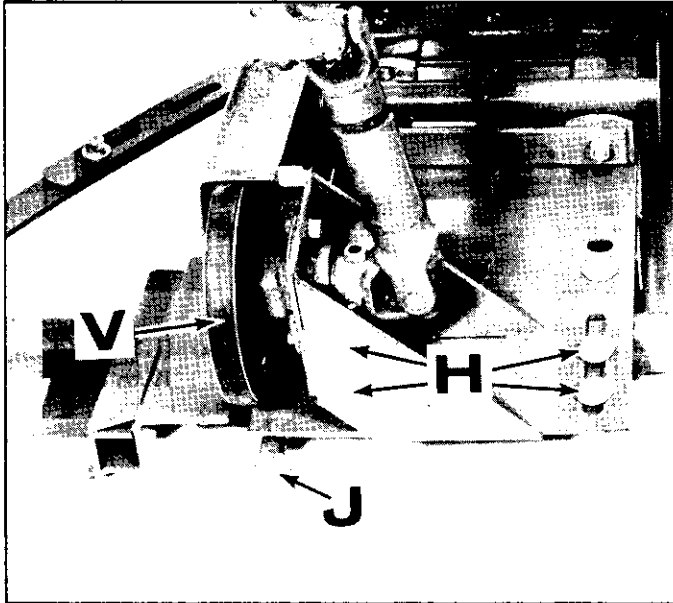

INSTALLATION OF LIFT HANDLE (Fig. 14)

Align hole in lift handle (G) with second hole in lift arm (H). Secure in place with 1/2" x 1 1/4" hex. bolt and hex. nut.

ALIGNMENT OF BELT RETAINER

Belt retainer (A) should be set 1/4" away from V-belt (Fig. 17).

Fig. 17

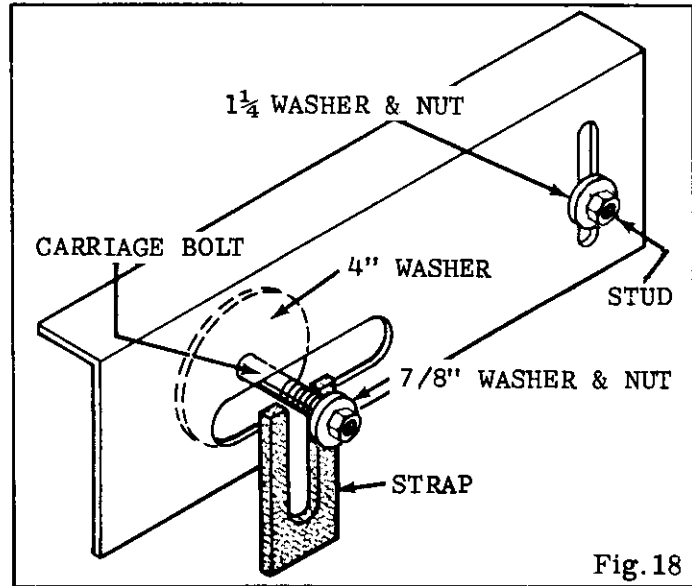
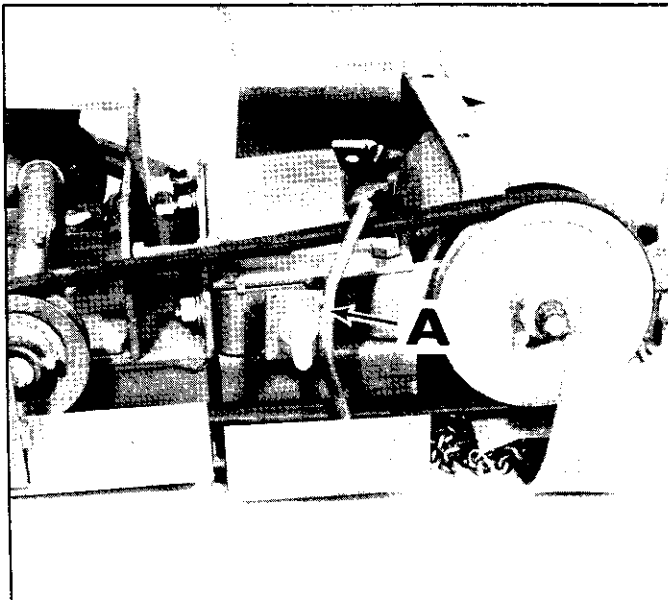

Fig. 18

INSTALLATION OF V-BELT GUARD (Fig. 18)

Install nut and 1-1/4" washer onto stud (Fig. 17). Insert 3/8 x 1" carriage bolt through 4" washer and 7/8" flat washer, and start nut. Place this assembly inside of V-belt guard so that bolt protrudes through large horizontal slot. Install guard over stud and slide carriage bolt into slot in strap with guard to the inside; nut and washer to the outside. Tighten nut to hold in place. Place a 1-1/4" washer and nut onto stud to secure guard.

INSTALLATION OF SICKLE BAR MOWER ON TRACTOR (Fig. 19)

Rear tube assembly (L) is placed under tractor as illustrated in Figure 19. (Tractor is not pictured here to give unobstructed view).

Place mower under tractor. Slide clamp shock absorbers of rear hanger (P) onto twin tubes of rear hitch (Q). Place rear hitch assembly under tractor and insert tube (L) into frame holder tube (M).

Fig. 19

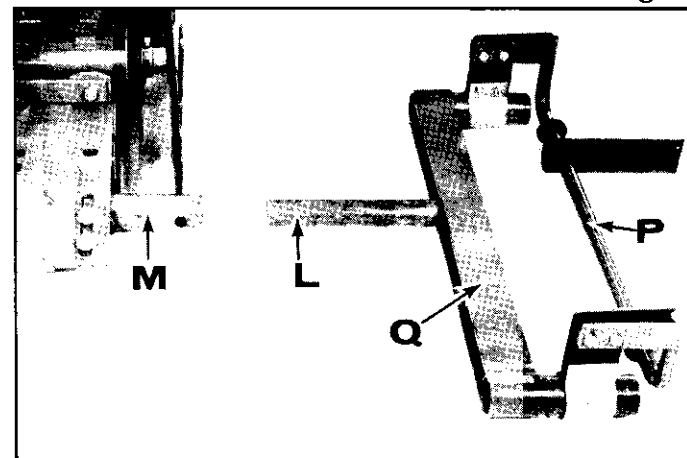

# SET UP

Lift rear of mower and place bar of rear into tractor mounting brackets (T). Swing down locking straps (V) and secure in place with hair cotter pins.

Fig. 20

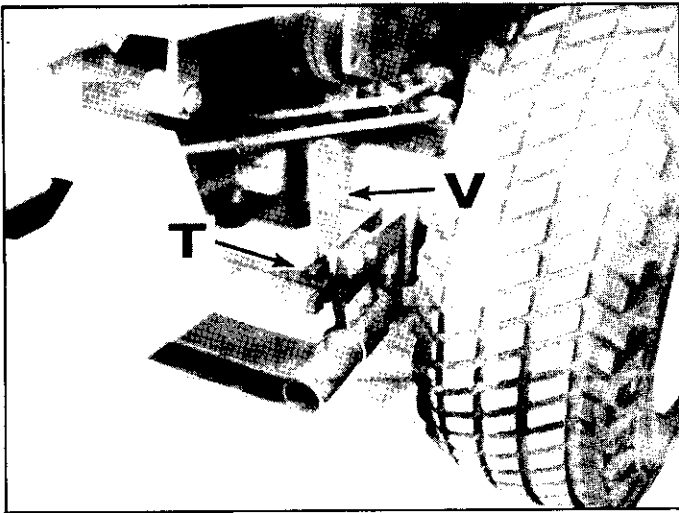

Raise front of sickel bar, placing axle between axle straps (R) of mower insert locating pins (S) and secure with hair cotter pins.

Fig. 21

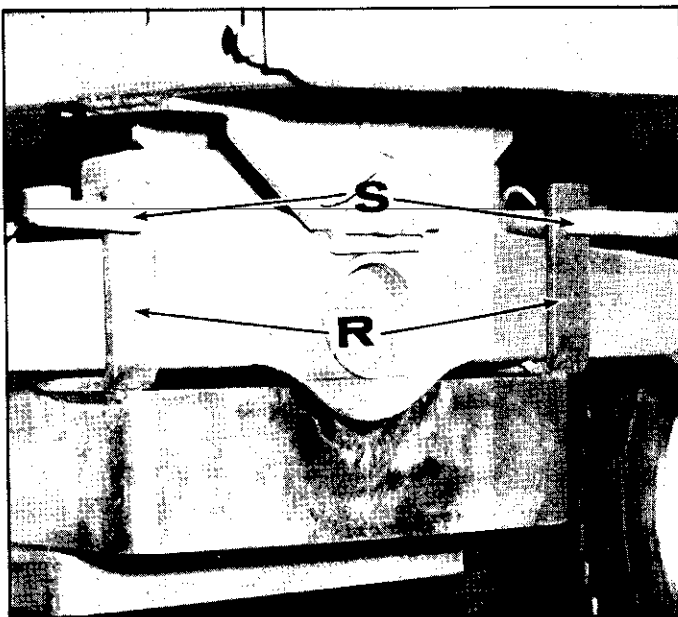

## ATTACHING PTO (Fig. 22)

Slide end of mower PTO (D) over tractor PTO spline (E) being sure to align holes. Insert pin and secure with clip spring. (Note: For easiest installation grease mating parts of mower PTO halves and tractor PTO spline).

Fig. 22

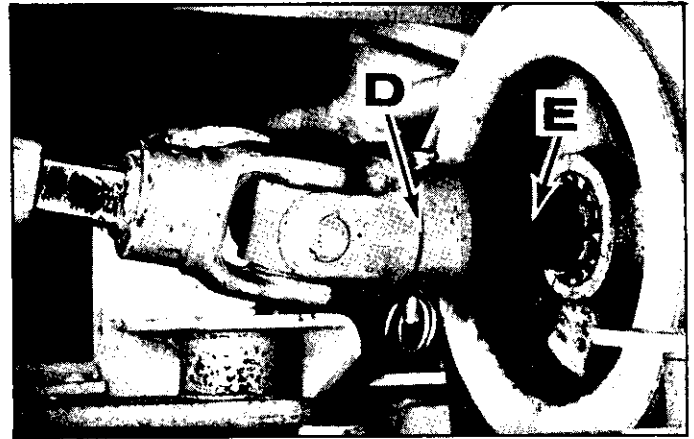

## TORSION SPRING HOOK-UP

Raise mower bar into vertical position and install torsion spring adjusting bolt (U) to torsion spring spur (V) as illustrated (Fig. 23).

Fig. 23

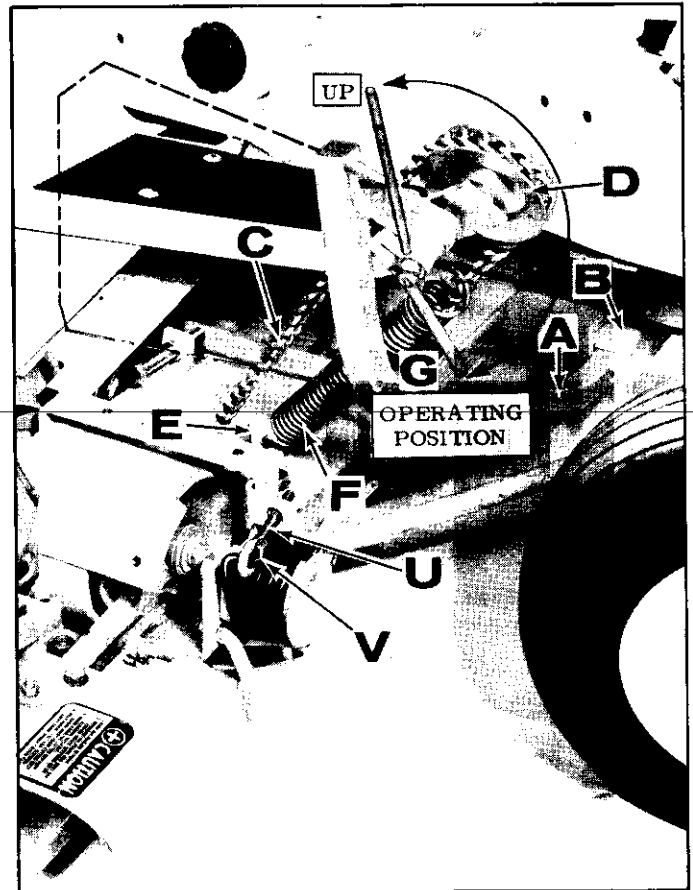

Next, install carrier arm assembly (A) (Fig. 23) by inserting carrier arm into mounting pocket (B). Push carrier arm into pocket (B) until carrier arm button stop rests against end of pocket mounting tube.

## INSTALLATION OF LIFT CHAIN AND SPRING TRANSPORTING MOWER: ASSEMBLY TO CARRIER ARM (Fig. 23).

Lift chain (C) should be threaded over carrier arm pulley (D). NOTE: Be certain that eccentric arm on carrier pulley is in "up" position at this point. Anchor clip (E) is positioned at angle shown and lift spring (F) is attached to angle clip (E). To connect lift spring to lift chain, remove all slack from chain, then connect lift spring (F) to lift chain (C) so the chain is snug. Then push pivot arm assembly into operating position (G) as illustrated in (Fig. 23).

Inner shoe of sickle should then be approximately 1/2" off floor at this point. For added clearance, drop additional links of chain. Having inner shoe approximately 1/2" off floor or ground level when sickle is not operating will allow inner shoe to float more easily over uneven terrain, precut material, and other obstructions.

### LIFT HANDLE POSITIONS: (Fig. 24 & Fig. 25)

Lift handle should be set in top notch as illustrated for operating sickle. Setting (H) is for transport position. Stop tractor engine, and disengage front tractor PTO clutch when ever dismounting from tractor (Fig. 24).

Install sickle knife cover (J) using retaining strap to secure cover to bar. Set lift handle into transport position (H). Stand in back of mower, raising mower bar with right hand to vertical position. Insert transport pin (K) as illustrated by sliding pin lever down from vertical to horizontal position as shown by arrow. Let pin slide through hole in strap (L) to lock in place. Avoid sudden or sharp turns with mower in transport position (Fig. 24-25).

Fig. 25

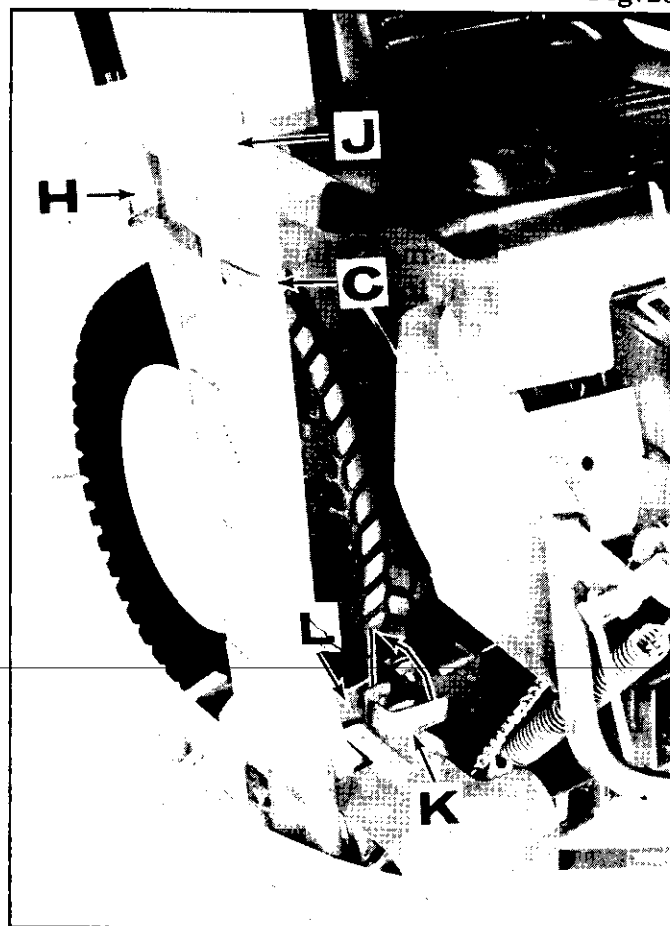

TRANSPORT POSITION

Fig. 24

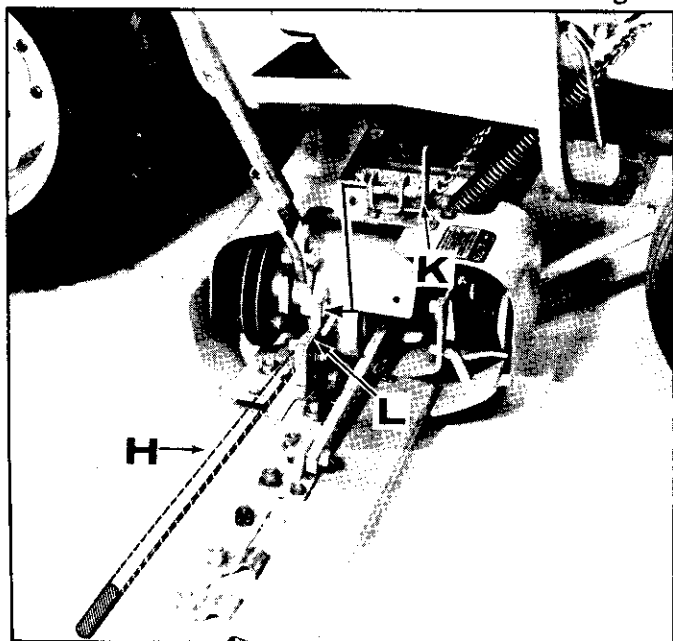

### OPERATION CHECK LIST

1. Make sure lift operates smoothly
2. Check chain tension
3. Check knife clearances
4. Check shear bar bolts
5. Check bolts that hold main cylinder to the base of the machine
6. Check all other bolts to make sure they are tight



E250

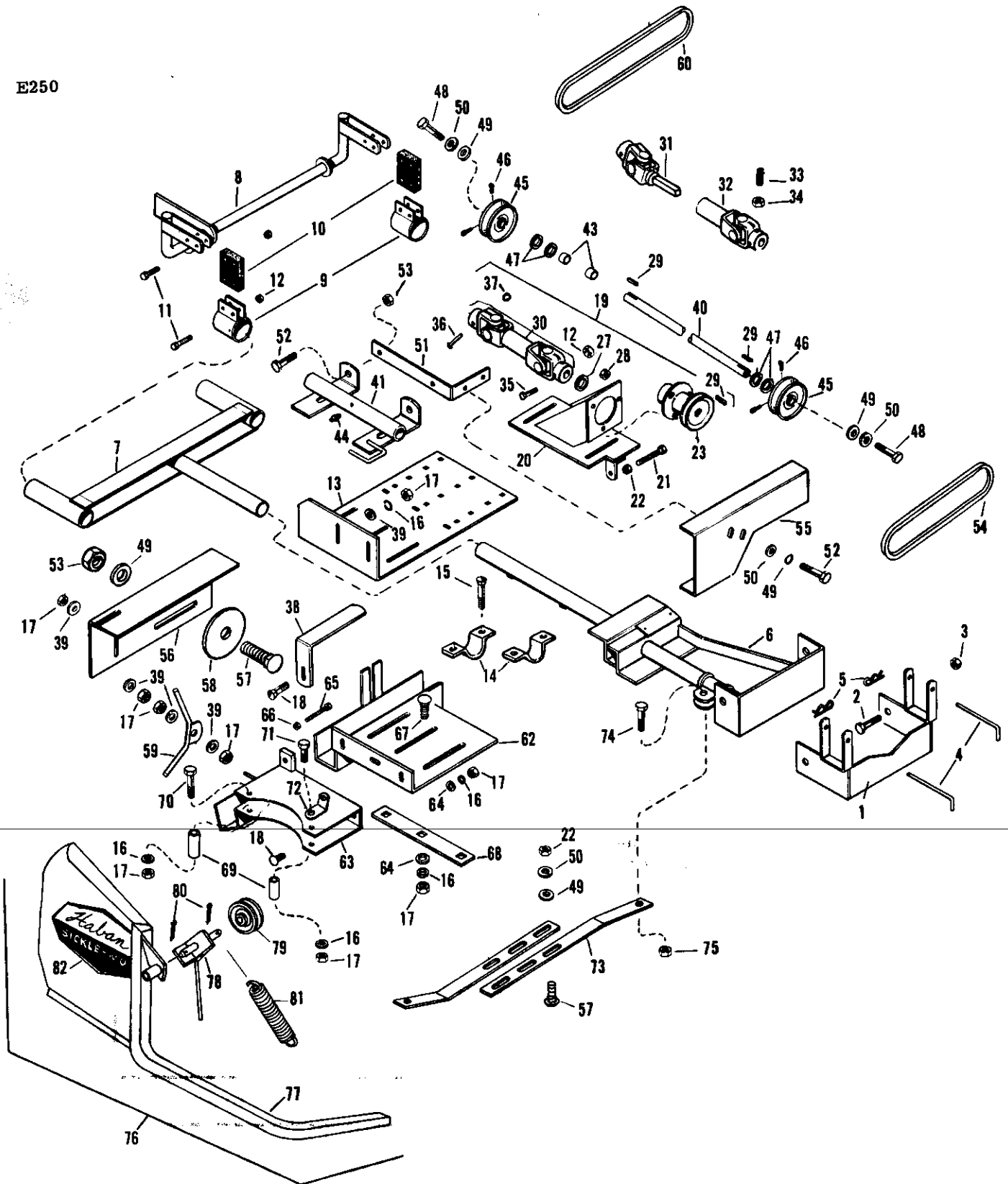

Haban Sickle Bar Mower - Model 413 For Gravelly Tractors

Specification changes beginning with Serial Number 202,140

<u>Ref. #</u>	<u>Part #</u>	<u>Description</u>	<u>No. Req.</u>
45	3970	Assy. Pulley & Hub	2
60	S-369	V-belt - Long	1

HABAN MODEL 413 SICKLE BAR MOWER ATTACHMENT

E251

Ref. No.	Part No.	Description	No. Req.	Ref. No.	Part No.	Description	No. Req.
1	8651	Assy - Front Hanger	1	43	8689	Bearing	2
2	GM431104	Bolt - 5/8-11 x 1-1/4 Hex	2	44	5074	Fitting - Grease	1
3	GM9414075	Nut - 5/8-11 Hex Lock	2	45	3252	Assy - Pulley & Hub	2
4	5236	Pin	2	46	GM142671	Screw - Set (5/16-18 x 1/2)	4
5	3341	Pin - Hair Cotter	4	47	3396	Washer - 3/4 Flat	4
6	6797	Assy - Pivot Frame	1			(49/64 x 1-1/2)	
7	8653	Assy - Rear Hitch	1	48	GM180120	Bolt - 3/8-16 x 3/4 Hex	2
8	8657	Assy - Rear Hanger	1	49	GM120388	Washer - 3/8 Flat (7/16 x 1)	7
9	3976	Clamp	2	50	GM120382	Washer - 3/8 Med. Lock	6
10	3977	Shock Absorber	2	51	7353	Bracket (Guard Support)	1
11	GM180024	Bolt - 1/4-20 x 1-1/4 Hex	8	52	GM180122	Bolt - 3/8-16 x 1 Hex Head	4
12	4119	Nut - 1/4-20 Hex Lock	9	53	GM271190	Nut & Lock Washer Assy -	3
13	8892	Plate - Frame Mounting	1			3/8-16 Hex Head	
14	3984	Bracket - Mounting	2	54	3742	V-Belt - Short	1
15	GM120917	Bolt - 1/2-13 x 1-1/2 Carr.	4	55	7354	Guard - V-Belt (Front)	1
16	GM120384	Washer - 1/2 Med. Lock	15	56	8981	Guard - V-Belt (Rear)	1
17	GM120378	Nut - 1/2-13 Lt. Hex	19	57	GM120915	Bolt - 3/8-16 x 1 Carr.	3
18	GM126485	Bolt - 1/2-13 x 1-1/4 Carr.	6	58	9142	Washer - 13/32 Sq. x	1
19	7674	Assy - Slip Support & Jackshaft Housing	1			4-1/4 x 12 ga.	
20	7344	Assy - Slip Assy. Support	1	59	8984	Assy - Belt Retainer	1
21	6475	Bolt - 3/8-16 x 3-1/2 Hex	1	60	9067	V-Belt - Long	1
22	GM120377	Nut - 3/8-16 Lt. Hex	3	62	8974	Assy - Crg. Adj. Plate	1
23	7675	Assy - Jackshaft Housing & Pulley (Comp)	1	63	8977	Assy - Breakaway Housing	1
				64	GM120396	Washer - 1/2 Flat	3
27	5429	Washer - 49/64 x 1-1/16 Flat	AR	65	5790	Bolt - 1/2-13 x 4 Hex Head	1
28	GM271184	Nut & Lock Washer Assy - 5/16-18 Hex Head	3	66	GM120238	Nut - 1/2-13 Lt. Half Hex	1
29	3259	Key	3	67	GM126499	Bolt - 1/2-13 x 1-3/4 Carr.	3
30	8956	Slip Assembly (Both Ends)	1	68	8243	Strap - Locator	1
31	8954	Yoke & (Male End) Rectangular Shaft	1	69	3554	Spacer	2
32	8955	Yoke (Female End)	1	70	GM180190	Bolt - 1/2-13 x 3 Hex Head	1
33	GM102594	Screw - Set (3/8-16 x 5/8)	1	71	GM180192	Bolt - 1/2-13 x 3-1/2 Hex	1
34	GM124829	Nut - 3/8-16 Lt. Half Hex	1	72	6073	Anchor - Spring	1
35	GM180042	Bolt - 1/4-20 x 1-3/4 Hex	1	73	8975	Stabilizer Straps	2
36	4001	Pin - Clevis	1	74	GM180175	Bolt - 1/2-13 x 1-1/4 Hex	1
37	5714	Clip	1	75	GM9414074	Nut - 1/2-13 Hex Lock	1
38	8980	Strap - Stop	1	76	5659	Assy - Carrier Bar (Comp)	1
39	GM120389	Washer - 7/16 Flat (1/2 x 1-1/4)	9	77	5660	Assy - Carrier Bar	1
40	7466	Jackshaft	1	78	5663	Assy - Pulley Mtg. Bracket	1
41	7349	Assy - J'Shaft Housing & Bushings	1	79	4676	Assy - Pulley & Hub	1
				80	GM120123	Pin - Cotter (1/8 x 1-1/4)	2
				81	3434	Spring - Transport	1
				82	5543	Decal	1

(5/9/74)

E248

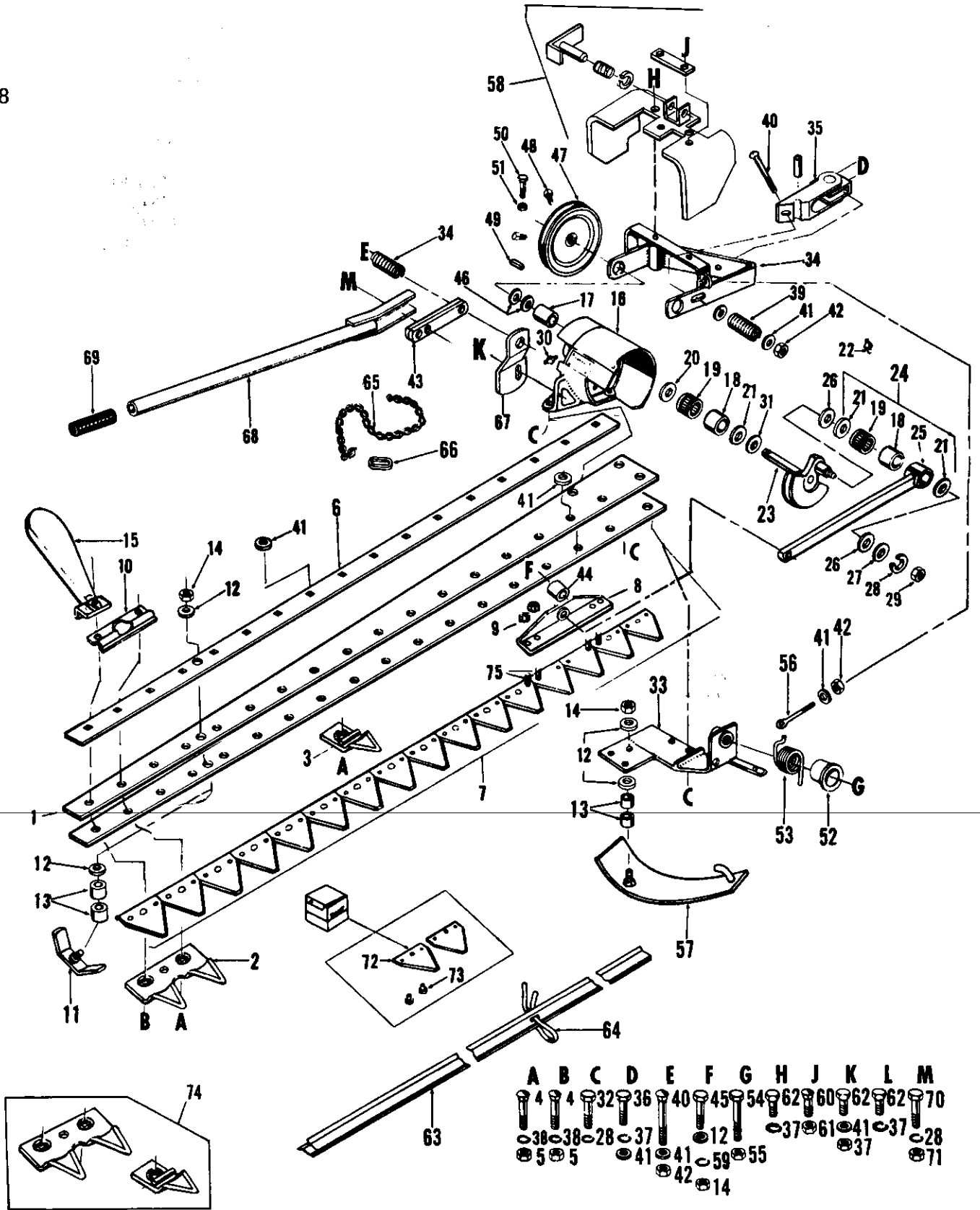

E249

Ref. No.	Part No.	Description	No. Req.	Ref. No.	Part No.	Description	No. Req.
1	9614	Bar - Sickle	2	39	3411	Spring	2
2	6732	Finger - Shear	8	40	8133	Bolt	2
3	7188	Assy - Shear Finger	1	41	GM120388	Washer - 3/8 Flat (7/16 x 1)	11
4	GM126452	Bolt - 7/16-14 x 1-1/2 Carr.	17	42	GM9413534	Nut - 3/8-16 Hex Lock	3
5	GM271501	Nut - 7/16-14 Lt. Hex.	17	43	5626	Strap - Lift	2
6	8996	Plate - Wear	1	44	1094	Bushing	1
7	8913	Assy - Sickle Knife	1	45	GM180179	Bolt - 1/2-13 x 1-3/4 Hex	1
8	8916	Assy - Knife Head	1	46	3396	Washer - 3/4 Flat (49/64 x 1-1/2)	2
9	8928	Nut	4	47	4638	Assy - Pulley & Hub	1
10	3598-A	Clip	5	48	GM142671	Screw - Set (5/16-18 x 1/2)	2
11	5571	Assy - Outer Shoe	1	49	3259	Key	1
12	GM120396	Washer - 1/2 Flat (17/32 x 1-1/16)	7	50	GM180042	Bolt - 1/4-20 x 1-3/4 Hex	1
13	3346	Spacer	4	51	4119	Nut - 1/4-20 Hex Lock	1
14	GM9414074	Nut - 1/2-13 Hex Lock	3	52	4645	Retainer - Torsion Spring	1
15	4648	Assy - Grass Divider Brd.	1	53	4655	Spring - Torsion	1
16	4707	Assy - Flywheel Housing	1	54	GM271724	Bolt - 5/8-11 x 2-1/4 Hex	1
17	3034	Bushing	1	55	GM124847	Nut - 5/8-11 Half Hex	1
18	4683	Race	2	56	3058	Eye Bolt	1
19	4684	Bearing	2	57	3604-A	Assy - Inner Skid Shoe	1
20	4653	Washer - 15/16 x 1-5/16	1	58	7823	Assy - Stop Housing	1
21	4656	Seal	3	59	GM138549	Washer	1
22	4123	Fitting - Grease	1	60	7090	Bolt	2
23	4641	Assy - Crankshaft	1	61	GM271178	Nut & Lock Washer Assy - 1/4-20 Hex Head	2
24	4685	Assy - Pitman & Bearings	1	62	GM180120	Bolt - 3/8-16 x 3/4 Hex	3
25	4629	Assy - Pitman	1	63	4690	Guard	1
26	4654	Washer - 15/16 x 1-1/2 Flat	2	64	4686	Assy - Guard Strap	1
27	GM120390	Washer - 1/2 Flat (9/16 x 1-3/8)	1	65	4716	Chain	1
28	GM120384	Washer - 1/2 Med. Lock	4	66	3436	Anchor	1
29	GM124934	Nut - 1/2-20 Half Hex	1	67	6850	Assy - Vertical Position Stop	1
30	5074	Fitting - Grease	1	68	6077	Assy - Lift Handle	1
31	4719	Washer - 15/16 x 2 Flat	1	69	3339	Grip - Handle	1
32	GM180177	Bolt - 1/2-13 x 1-1/2 Hex.	3	70	GM180175	Bolt - 1/2-13 x 1-1/4 Hex	1
33	3570	Assy - Sickle Mtg. Bracket	1	71	GM120378	Nut - 1/2-13 Lt. Hex	1
34	3555-A	Assy - Breakaway Pivot	1	72	8030	Knife Kit - Box of 25	1
35	5602	Assy - Latch	1	73	8163	Box of Rivets	1
36	GM180122	Bolt - 3/8-16 x 1 Hex Hd.	2	74	9281	Shear Finger Kit (8 dbl. 1 single)	1
37	GM120382	Washer - 3/8 Med. Lock	5	75	8904	Bolt	4
38	GM120383	Washer - 7/16 Med. Lock	15				

5/13/74