



GRAVELLY[®]

**CONVERTIBLE 7.6
SERVICE
MANUAL**

 **GRAVELLY**

One Gravelly Lane
Clemmons, North Carolina 27012

INTRODUCTION

This manual is designed to give servicemen an indepth service procedure for the Convertible 7.6 tractor, and as an aid in diagnosis and repair.

This manual cannot take the place of proper routine maintenance, care and adjustments.

Gravely reserves the right to change specifications, or design at any time without notice or incurring obligation.

LH means Left Hand.

RH means Right Hand.

Directions are given from the operators position; that is, as you would stand behind the tractor.

TABLE OF CONTENTS

Trouble Shooting (Engine)	4
Air Intake System	5
Lubrication	5
Fuel System	6
Electrical System	8
Governor	9
Cleaning	10
Engine Tests	10
Engine - General Service	11
Fan	11
Engine Reconditioning	11
Cylinder Reconditioning	12
Transmission Trouble Analysis	18
PTO	19
Forward-Reverse	19
High-Low	20
Differential (2-Speed)	20
Differential (Std)	22

SAFETY PROCEDURES

IT IS TOO LATE TO REMEMBER WHAT SHOULD HAVE BEEN DONE AFTER THE ACCIDENT HAS HAPPENED.

Many hours of lost time and much suffering can be caused by the failure to practice simple safety rules.

1. Make sure the work area is clear of objects that might be picked up and thrown.
2. Do not wear loose fitting clothing that might get caught in moving parts.
3. Disengage all clutches prior to starting the engine.
4. Do not add fuel to the tractor when it is hot, while it is running, or while you are smoking.
5. Never run the engine in a closed garage or shed without adequate ventilation.
6. Do not try to oil or grease the tractor or its attachments while in operation.
7. Adequate ventilation must be provided when batteries are being recharged.

In addition, sparks, open flames and smoking should be avoided since hydrogen gas is produced which, if ignited, can cause internal explosion that can shatter the battery. This gas is produced in quantity only while the battery receives high rate of charge but can linger for several hours in a poorly ventilated area.

TROUBLE SHOOTING

CONDITION	POSSIBLE CAUSE
A. Hard Starting or Loss of Power Check for dirty air cleaner first.	<ol style="list-style-type: none"> 1. Faulty Ignition. <ol style="list-style-type: none"> a. Loose or grounded high tension or breaker point leads. b. Improper breaker point gap and timing. c. Defective breaker points. d. Faulty spark plug or improper gap. e. Faulty condenser or coil. 2. Faulty Fuel System. <ol style="list-style-type: none"> a. Gasoline not getting to carburetor. Dirt or gum in fuel line. b. Dirt in carburetor. c. Carburetor improperly adjusted.
B. Overheating	<ol style="list-style-type: none"> 1. Insufficient available cool air. 2. Dirty air intake screen, shroud or cooling fins. 3. Improper fuel. 4. Fuel mixture too lean. 5. Improper ignition timing. 6. Engine overloaded. 7. Tight tappet clearance.
C. Backfiring	<ol style="list-style-type: none"> 1. Fuel mixture too lean. 2. Improper timing. 3. Valve "sticking".
D. Occasional "Skip" at High Speed	<ol style="list-style-type: none"> 1. Spark plug gap too wide. 2. Improper carburetor setting or lack of fuel. 3. Wrong type spark plug. Use recommended spark plug. 4. Improper timing.
E. Operating Erratically	<ol style="list-style-type: none"> 1. Clogged fuel line. 2. Water in fuel. 3. Faulty choke control. 4. Improper fuel mixture. 5. Loose ignition connections. 6. Air leaks in manifold or carburetor connections. 7. Vent in gas cap plugged.
F. Engine Will Not Idle	<ol style="list-style-type: none"> 1. Improper carburetor idling adjustment. 2. Carburetor clogged. 3. Spark plug gap set too close. 4. Leaking carburetor or manifold gaskets.

AIR INTAKE SYSTEM

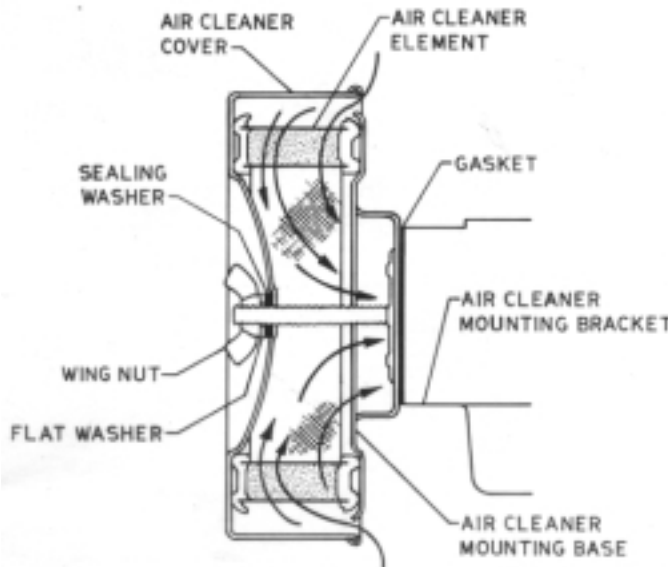

Figure 1

The importance of maintaining an air cleaner in proper condition cannot be over-emphasized! Dirt induced through improperly installed, improperly serviced for inadequate dry type elements, wears out more engines than does long hours of operation. Furthermore,

operating with a clogged element causes a richer fuel mixture which can lead to formation of harmful sludge, deposits. Always cover carburetor or air horn when air cleaner is removed for servicing.

Dry type air cleaner elements should be serviced only when required. Need for air cleaner service is evident by a sudden loss of power for no apparent reason.

To clean, remove element and tap lightly on a flat surface to remove loose surface dirt. Replace element if dirt does not drop off easily or if the element is damaged in any way. Also, replace element if there is any evidence of dirt on the inside surface of the element.

DO NOT wash dry elements in any liquid or attempt to blow dirt off with air hose as this will puncture the filter element.

Handle new element carefully - do not use if the gasket surfaces are bent, twisted or damaged in any way. Use only genuine Gravely elements. Use of other elements will void warranty. Not only must the proper element be used but it must be properly installed to prevent unfiltered air from entering the engine.

Install the air cleaner assembly in this sequence on the air cleaner mounting bracket:

1. Rubber gasket
2. Air cleaner mounting base
3. Element
4. Air cleaner cover
5. Rubber sealing washer
6. Flatwasher
7. Wing Nut

Be sure the element gasket surfaces fit tightly on the base and cover. The wing nut should be finger tight.

LUBRICATION

Oil capacity is 5 U. S. pints. Use API classification SC or SD oils.

Summer - SAE 30 or SAE IOW 30.

Winter - (32° F or below) SAE 10W or SAE 10W 30.

Maintain at oil level at full mark on dipstick. Be sure tractor is level when checking oil.

Oil Changes

Change the oil after the initial eight hours of operation. Then change the oil every 40 hours under normal conditions, oftener under dusty conditions and/or periods of extended operation.

Drain oil by removing the oil drain plug, the bottom bolt on the L. H. axle housing.

Be sure oil drain washer is in place when replacing the bolt.

Oil Filter

Under normal conditions, change the oil filter every 80 hours, however, under extremely dusty conditions and/or extended operation under heavy load, change the oil filter every 40 hours.

The oil filter must be installed by hand. Install the filter following the instructions printed on the filter.

Periodic oiling of all linkage pivot points aids operation.

FUEL SYSTEM

CARBURETOR

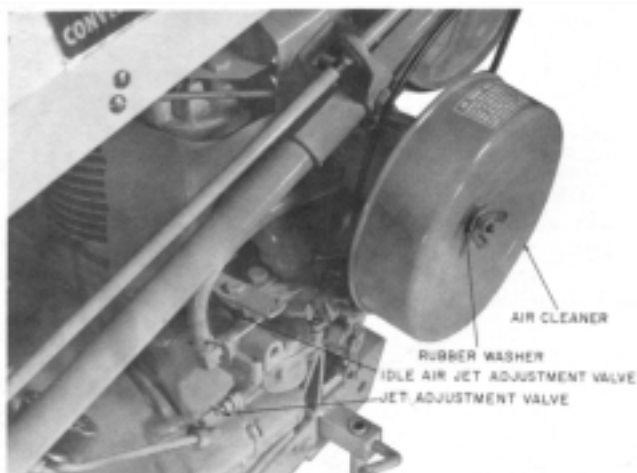

Figure 2

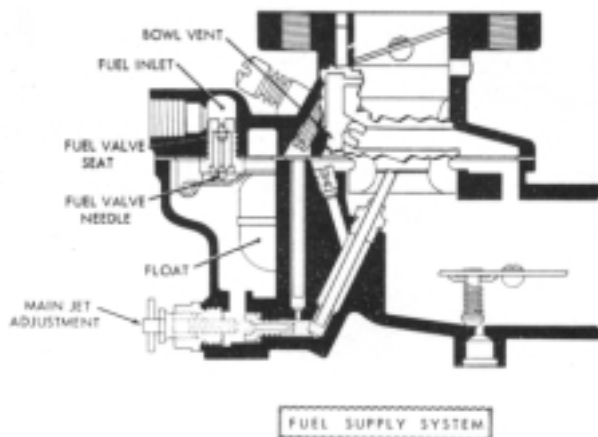

Figure 3

A. Adjustment

1. Screw the main jet adjustment needle (a brass T-needle) in until it is snug. Do not force or screw it tightly.
2. Back off the main jet adjustment needle $1\frac{1}{2}$ turns.
3. Start the engine and open the throttle halfway.

After the engine warms up, begin screwing the needle, slowly. As soon as the engine begins to slow down, stop and back the needle off until the engine picks up speed.

4. Screw the idle air jet adjustment needle all the way in; then back off one turn. Start the engine and allow it to idle. Screw the needle in until the engine begins to run rough. Then back the needle off until engine runs smooth.

FUEL SUPPLY SYSTEM

(See Figure 3)

The fuel supply system is made up of the threaded fuel inlet, the fuel valve seat, fuel valve needle, float and fuel bowl.

The fuel supply line is connected to the threaded inlet. The fuel travels through the fuel valve seat and passes around the fuel valve and into the fuel bowl. The level of the fuel in the fuel chamber is regulated by the float through its control of the fuel valve. The fuel valve does not open and close alternately but assumes an opening, regulated by the float, sufficient to maintain a proper level in the fuel chamber equal to the demand of the engine according to its speed and load.

The inside bowl vent as illustrated by the passage originating in the air intake and continuing through to the fuel bowl, is a method of venting the fuel bowl to maintain proper air fuel mixtures even though the air cleaner may become restricted. This balancing is frequently referred to as an "inside bowl vent".

IDLE SYSTEM

(See Figure 4)

The idle system consists of two idle discharge holes, idle air passage, idle adjusting needle, idle jet and fuel pick-up passage.

The fuel for idle is supplied through the main jet to a well directly below the main discharge jet. The pick-up passage is connected to this well by a restricted drilling at the bottom of this passage. The fuel travels

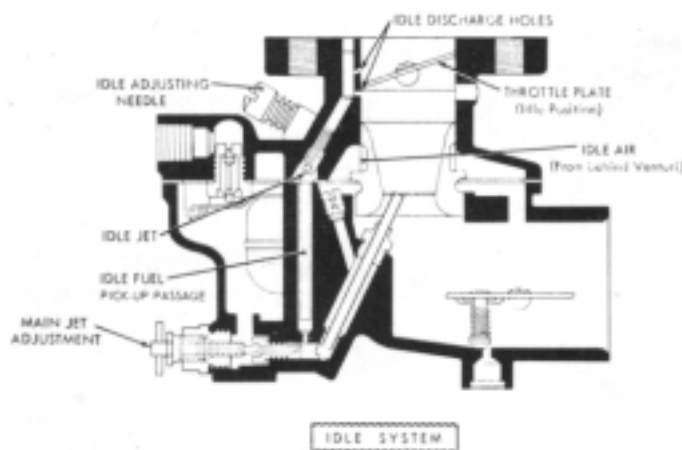

Figure 4

through this channel to the idle jet calibration. The air for the idle mixture originates back of (or from behind) the main venturi. The position of the idle adjusting needle (normally one turn from its seat) in this passage controls the suction of the idle jet and thereby idle mixture. Turning the needle in closer to its seat results in a greater suction with a smaller amount of air and therefore a richer mixture. Turning the needle out away from its seat increases the amount of air and reduces the suction, and a leaner mixture is delivered. The fuel is atomized and mixed with the air in the passage leading to the discharge holes and enters the air stream at this point.

HIGH SPEED SYSTEM

(See Figure 5)

The high speed system controls the fuel mixture at part throttle speeds and a wide open throttle. This system consists of a venturi, controlling the maximum volume of air admitted into the engine; the main jet, which regulates the flow of fuel from the float chamber to the main discharge jet; the well vent, which maintains uniform mixture ratio under changing suction and engine speeds; and a main discharge jet, which delivers the fuel into the air stream.

The main jet controls the fuel delivery during the

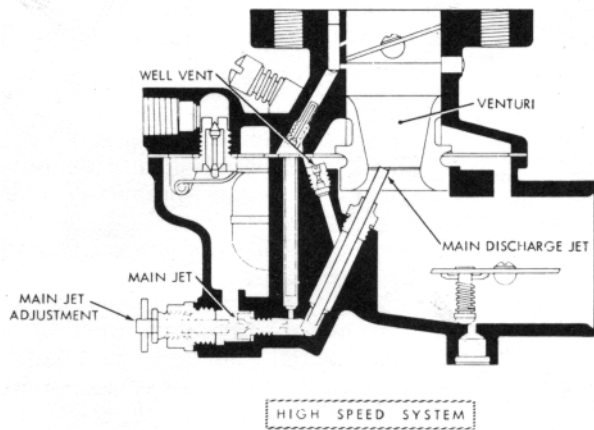

Figure 5

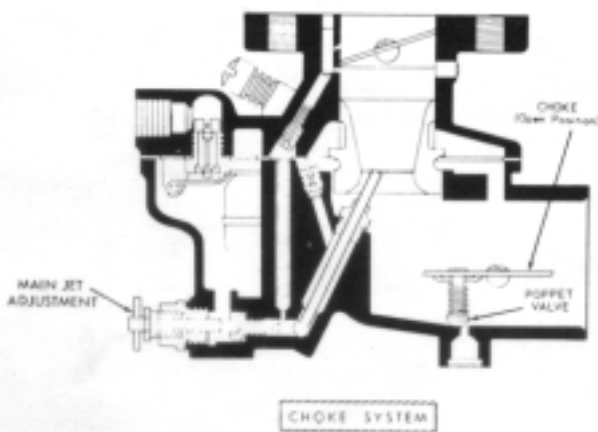

Figure 6

part throttle range from about one-quarter to full throttle opening. A main jet adjustment permits a limited control of the main jet fuel. Ordinarily an adjustment of 1 1/2 turns from its seat will give proper mixture. To maintain a proper mixture ration a small amount of air is admitted through the well vent into the discharge jet through the air bleed holes in the discharge jet at a point below the level of fuel in the metering well.

CHOKE SYSTEM

(See Figure 6)

At high speeds the fuel flows from the fuel chamber through the main jet and into the main discharge jet where it is mixed with air admitted by the well vent, and the air-fuel mixture is then discharged into the air stream of the carburetor.

The choke system consists of a valve mounted on a shaft located in the air entrance and operated externally by a lever mounted on the shaft. The choke valve is used to restrict the air entering the carburetor. This increases the suction on the jets when starting the engine. The choke valve is of a "Semi-Automatic" type, having a poppet valve incorporated in its design, which is controlled by a spring.

The poppet valve opens automatically when the engine starts and admits air to avoid over-choking or flooding of the engine. The mixture required for starting is considerably richer than that needed to develop power at normal temperatures. As the engine fires and speed

and suction are increased, the mixture ratio must be rapidly reduced. This change is accomplished through adjustment of the choke valve and the automatic opening of the poppet valve to admit more air when the engine fires.

SEPARATE CARBURETOR BODIES

- (a) Remove the four assembly screws using a screw driver.
- (b) Separate the throttle body from the fuel bowl assembly.

DISASSEMBLE THROTTLE BODY

- (a) Remove float axle as follows:
 - (1) Press screwdriver against float axle at slotted side of float hinge bracket and force through hinge bracket.
 - (2) Remove float axle completely with fingers from opposite side and remove float.
- (b) Remove fuel valve needle.
- (c) Remove the assembly gasket.
- (d) Remove the fuel valve seat and fibre washer.
- (e) Remove the idle jet using a small screwdriver.
- (f) Remove the idle adjusting needle and friction spring.

DISASSEMBLE FUEL BOWL BODY

- (a) Remove the main jet adjusting needle assembly and fibre washer using a 1/2" wrench.
- (b) Remove the drain plug (hex) from bottom of fuel bowl.
- (c) Remove main jet and fibre washer.
- (d) Remove main discharge jet and fibre washer from center of large opening in machined surface of the fuel bowl.
- (e) Remove well vent jet from center of large opening in machined surface of the fuel bowl with a small screwdriver.

CLEANING PARTS

- (a) Clean all metal parts thoroughly with cleaning solution and rinse in solvent.
- (b) Blow out all passages in the air intake and fuel bowl casting and throttle body.
- (c) NOTE: Be sure all carbon deposits have been removed from throttle bore and idle discharge holes. It is advisable to reverse flow of compressed air in all passages to insure that all dirt has been removed. Never use a wire or drill to clean out jets.

INSPECTION OF PARTS

- (a) Float Assembly. Replace float assembly if loaded with gasoline, damaged, or if float axle bearing is worn excessively. Inspect top side of float lever for wear where it contacts fuel valve needle.

NOTE: Such wear can affect the float level.

- (b) Float Axle. Replace if any wear can be visually detected on the bearing surface.
- (c) Fuel Valve Seat and Needle Assembly. Always replace fuel valve seat and needle because both parts wear and may cause improper float level.
- (d) Idling Adjustment Needle and Spring. Inspect point of needle. This must be smooth and free of ridges.
- (e) Gaskets. Replace all gaskets and fibre washers every time the carburetor is disassembled.

REASSEMBLY

FUEL BOWL BODY

- (a) Install main discharge jet and fibre washer in fuel bowl and tighten firmly.
- (b) Install well vent jet in fuel bowl and tighten with a small screwdriver.

- (c) Install main jet and fibre washer.
- (d) Install the drain plug (hex) in threaded passage bottom of fuel bowl
- (e) Install main jet adjustment seat lightly and back out 1 1/2 turns.

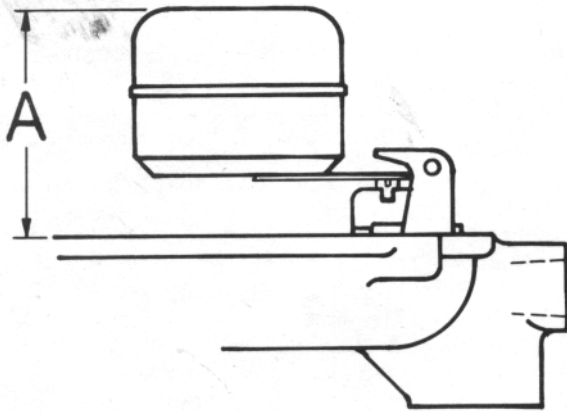

Figure 7

THROTTLE BODY

- (a) Install idle adjusting needle and friction spring in threaded passage on side of throttle body. Seat lightly with screwdriver and back out one full turn.
- (h) Install idle jet.

- (c) Install fuel valve seat and fibre washer.
- (d) Install fuel valve needle in seat followed by float and float axle.

SEE FIGURE 7. The "A" dimension should be 1 5/32 inch plus or minus 3/64 inch.

- (e) Float Level. Check position of float assembly for correct measurement to obtain proper float level using depth gauge.

NOTE: Do not bend, twist or apply pressure on the float bodies.

- 1 (1) With bowl cover assembly in an inverted position, viewed from free end of float, the float must be centered and at right angles to the machined surfaces. The float setting is measured from the machined surfaces (no gasket) of cover to top side of the float bodies at highest point.
- (2) Bending Float Lever. To increase or decrease distance between float body and machined surface use long-nosed pliers and bend lever close to float body.

NOTE: Replace with new float if position is off more than 1/16 inch.

ASSEMBLE CARBURETOR BODIES

- (a) Assemble the two completed bodies and four screws and tighten screws evenly and firmly.
- (b) Hold the throttle lever in a closed position and turn the throttle stop screw in until it just contacts the stop on body, then turn screw in 1 1/2 additional turns.

ELECTRICAL SYSTEM

Spark Plug -Champion H-8 Gap - .025 inch

Timing

1. Remove cylinder head and gasket.
2. Loosen magneto coupling bolt until coupling will slip on the camshaft extension.
3. Bring the piston to top dead center on compression stroke (both valves closed).
4. Back piston down cylinder approximately one inch by turning starter pulley counterclockwise.
5. Measure accurately 3/8 inch from top of cylinder and bring piston up to this point.
6. Align the timing marks (straight marks) on magneto.
7. Reassemble the magneto coupling using .015 feeler gauge between the fibre block and the coupling flange before tightening bolt so as not to clamp the impulse.
8. Reinstall head and gaskets torquing to 20 ft. lbs.

LUBRICATION

The only lubricating point in the magneto is the cam wiper felt. This felt, which lubricates the breaker arm at point of contact with the cam, should be lubricated with 2-3 drops oil whenever it is necessary to replace the breaker contacts.

IMPORTANT

Incorrectly adjusted spark plug gaps cause magneto failure more frequently than any other condition. Spark plugs should be inspected at frequent intervals, the size of the gap should be carefully checked and adjusted and the plugs thoroughly cleaned. All oil, grease, and dirt should frequently be wiped off the magneto, lead wires, and spark plug insulators.

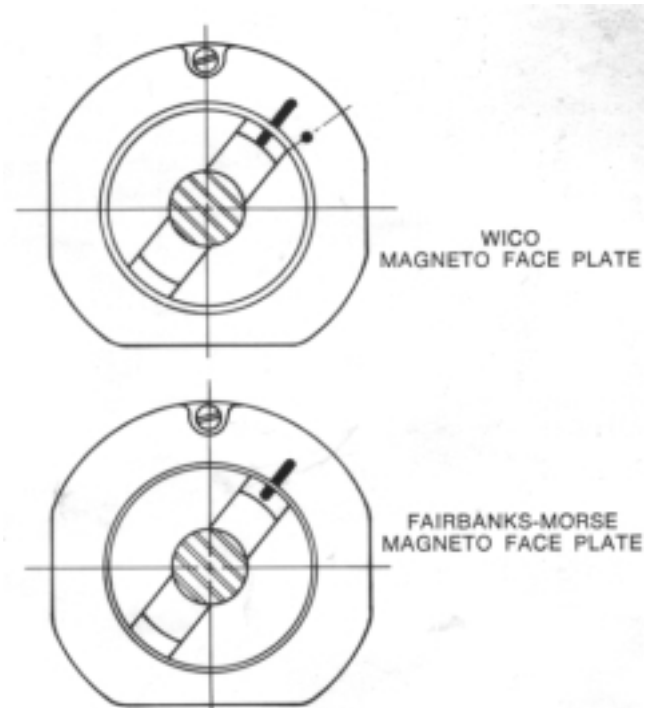

Figure 8

Keeping these parts clean and the spark plugs properly adjusted will improve the engine performance and at the same time will prolong the life of the magneto.

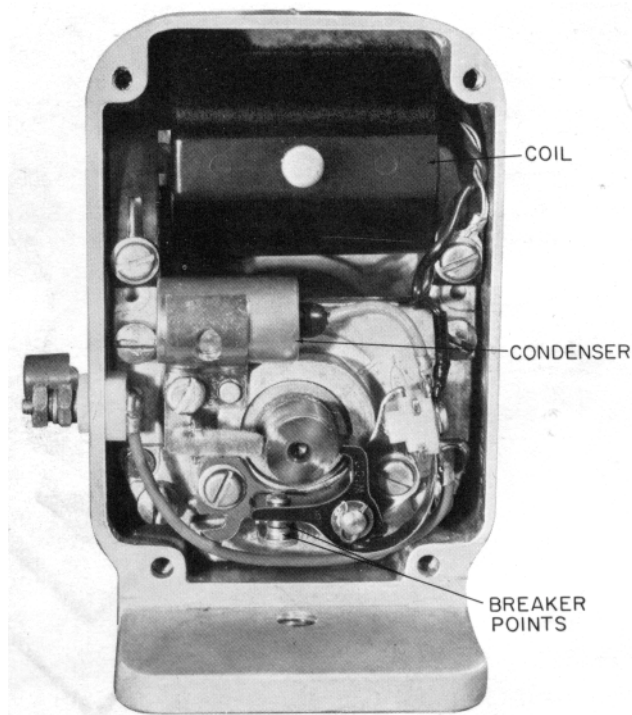

Figure 9

MAGNETO COVER .

The magneto cover, can be removed by loosening the four screws which hold it in place. When replacing the cover be sure that the cover gasket is in its proper place.

BREAKER CONTACTS -REPLACEMENT

AND ADJUSTMENT

The breaker contacts should be adjusted to .015" when fully opened. To adjust the contacts, loosen the two clamp screws enough so that the contact plate can be moved. Insert the end of a small screw driver in the adjusting slot and open or close the contacts by moving the

plate until the opening is .015", measuring with a feeler gauge of that thickness, tighten the two clamp screws.

To replace the contacts remove the breaker, the spring clamp screw, the breaker arm lock and washer, and then lift the breaker arm from its pivot. Remove the spacing washer and the two breaker plate clamp screws. The breaker plate can then be removed.

If the contacts need replacing it is recommended that both the fixed contact and the breaker arm be replaced at the same time, using replacement breaker set.

After assembly the contacts should be adjusted as described above. The contacts should be kept clean at all times. Lacquer thinner is an ideal cleaner for this purpose.

CONDENSER

To remove the condenser, first disconnect the condenser lead by removing the breaker arm spring screw, then remove the two condenser clamp screws, and the condenser clamp. When replacing the condenser make sure it is properly placed and that the clamp screws are securely tightened.

COIL AND COIL CORE

The coil and coil core must be removed from the magneto housing as a unit. Disconnect the primary wire from the breaker arm spring terminal by removing screw, take out the two coil core clamp screws, and remove the clamps. The coil and core can then be pulled from the housing. When replacing this group make sure that the bare primary wire is connected under the core clamp screw and that the insulated wire is connected to the breaker arm spring terminal.

REMOVAL OF COIL FROM CORE

The coil is held tight on the core by two wedges. It will be necessary to press against the coil core with considerable force to remove it from the coil. The coil should be supported in such a way that there is no danger of the primary of the coil being pushed out of the secondary.

When replacing the coil on the coil core, slide it on then press in the two coil wedges, one on each end, until they are flush with the primary of the coil.

GOVERNOR

Governor service is indicated when the governor is not functioning properly under load.

Two governor repair kits are available. If the components of these kits cannot repair the governor, it will be necessary to replace the governor.

1. Main shaft assembly kit consists of: Retainer Bearing
Main Shaft Assembly
2. Seal repair kit consists of: Oil Seal Oil Seal Gasket

GOVERNOR OVERHAUL PROCEDURE. Remove the governor from the tractor, and proceed as follows:

1. Remove two screws and separate cover assembly from body assembly.
2. Remove retainer and thrust sleeve from cover and main shaft assembly.
3. Remove two flyweight pivot pin retainers and carefully tap out flyweight pivot pins using a 1/8

diameter punch, and tapping against the grooved end of the pivot pin.

4. Remove two screws and rocker lever from body assembly.
5. Slip out shaft and lever assembly from body assembly.
6. Clean all parts carefully in a suitable solvent, to remove all grease, dirt and foreign material.
7. Inspect all parts carefully for wear, cracks or damage and replace parts as necessary. A main shaft assembly kit and seal repair kit are available. Replace the governor if the parts in these kits cannot repair the governor.
8. Inspect for excessive wear on main shaft, pivot pins, thrust sleeve and cross shaft & lever. Replace as necessary.
9. Inspect for excessive wear on main bearing and rear bearing and cross shaft bearings in body. Replace body as a unit if bearings are worn or damaged.
10. Replace spring if it is damaged or if loss of tension is apparent.

11. Replace seals if damaged or worn.
12. Re-assemble the governor in the reverse order of disassembly.

IMPORTANT: Pack the internal component parts, especially the bearings, pins, shafts and all rotating and sliding parts, with lubricant. A total of 3 ounces of this lubricant is to be packed within the governor housing, in order to supply maintenance-free operation of the governor.

CLEANING

A clean tractor is much easier to work on than a dirty one. Also, dirt will be prevented from entering the tractor. After being repaired it will look better and operate cooler.

On extremely dirty tractors, it may be necessary to raise the fuel tank and fan housing assembly to clean the tractor thoroughly.

CAUTION: Before steam cleaning a tractor, remove the magneto. Use care in cleaning around the carburetor, do not direct the steam or water into the air cleaner. After cleaning replace the air cleaner element.

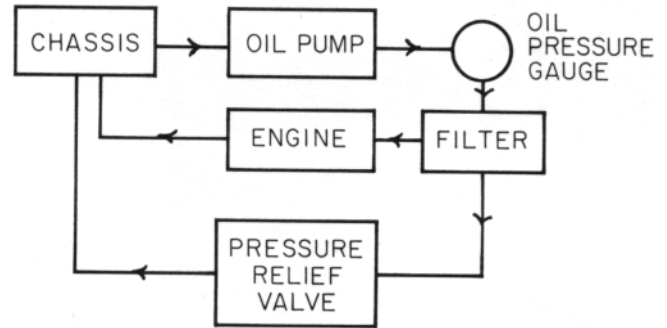

ENGINE TESTS

Oil Pressure: At full throttle (2600-2800 rpm), the hand on the oil pressure gauge should be approximately 3/4 of the way over the normal range.

Low oil pressure is a possible indication of a serious problem. However, before teardown, check the following:

<i>PROBLEM</i>	<i>REMEDY</i>
Low oil level	Check level, add oil as required.
Low rpm	Adjust to 2600-2800 rpm at full throttle.
Low relief valve setting	Adjust relief valve setting, with adequate pressure, a heavy stream should still be visible through the oil filler neck.
Lose of pump suction due to air leak -usually evident by oil leak.	Check fittings for tightness. Torque pump cap bolts to 80 in. lbs.

Compression: The results of a compression test can be used to check the condition of an engine. High compression readings, 70-80• psi, indicates the engine is in good operating conditions.

LOW COMPRESSION

<i>POSSIBLE CAUSE</i>	<i>REMEDY</i>
A. Cylinder head gasket blown due to cylinder head warped or loose. B. Piston rings worn - blowby occurring. C. Valves leaking.	A. Remove head, check for flatness. Reinstall with new gasket and secure in proper sequence to specified torque valve. . B. Recondition cylinder, see page 12 C. Recondition cylinder, see page 12

Higher than normal compression can indicate that excessive carbon deposits have built up in the combustion chamber.

ENGINE GENERAL SERVICE

COOLING

If tractor is getting hot, check for blockage of the cooling system. Air is blown around the cylinder and across the cylinder head by the fan. The fan housing and the cooling fins on the cylinder and cylinder head must be kept clean and unobstructed at all times.

NEVER OPERATE WITHOUT FAN OR FANBELT OR WITH ANY AIR DEFLECTOR OFF. The air deflector directs air flow around the cooling fins. Removal results in improper air circulation.

Improper timing can cause tractor to run hot.

EXTERNAL SURFACES

External surfaces (tractor as well as engine) must be maintained in a clean condition, free of any dirt or oil accumulation which reduces cooling efficiency.

FAN

The fan shaft is supported by two bearings with a spacer between them. The bearing housing is packed with general purpose grease upon assembly.

Whenever a tractor is overhauled the bearing housing should be repacked with grease. Be sure the spacer is in place between the bearing.

ENGINE RECONDITIONING

ENGINE REMOVAL

1. Remove any attachment from tractor and replace with attachment cover plate. Tip tractor forward on advance casting.
2. Disconnect throttle and choke controls from carburetor.
3. Turn off fuel and remove fuel line from carburetor
4. Remove the air cleaner assembly. Remove air cleaner hose from carburetor and the air cleaner mounting bracket.
5. Disconnect governor linkage, if so equipped.
6. Remove the L.H. air deflector.
7. Remove fan belt.
8. Remove the bolt securing the High-Low and Forward-Reverse controls at R.H. handle.
9. On swiftomatic tractors, disconnect the shifter rod from the shifter handle on the R.H. Handle.
10. Disconnect kill wire from magneto.
11. Remove R.H. air deflector. .
12. Remove cylinder air deflector.
13. Remove nuts and lockwashers from fan housing bracket weldments.
14. Loosen bolts securing rear hitch to transmission and

- bolts securing hitch braces to hitch. Remove hitch braces from fan housing brackets and lower hitch to floor.
15. Loosen bolts securing handles to the fan housing and bolts securing handles to transmission.

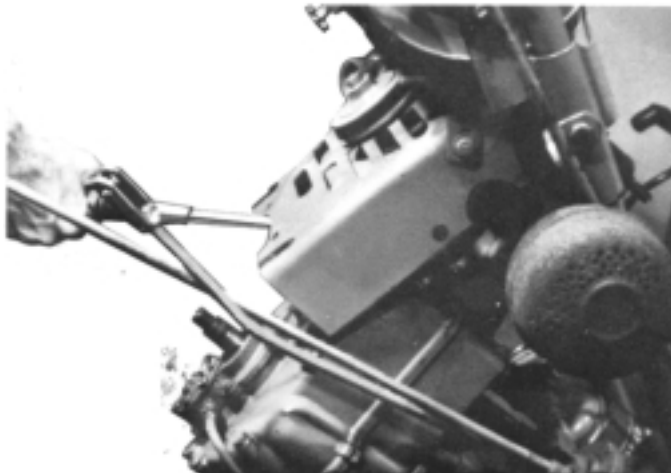

Figure 11

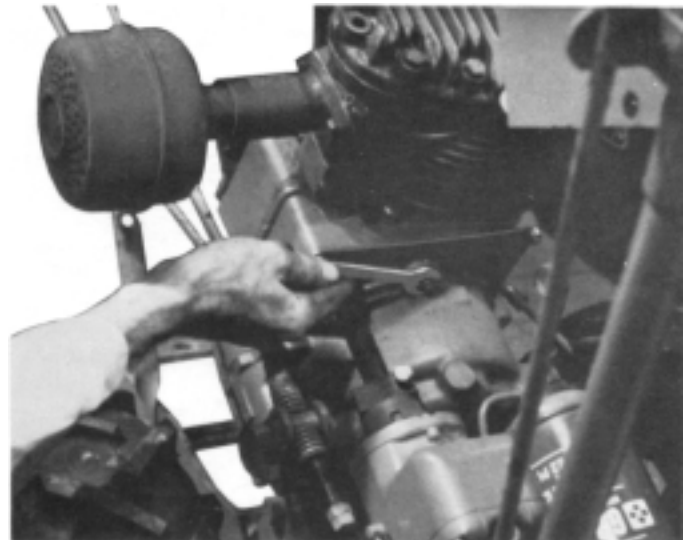

Figure 12

16. Pull out bottom of fan housing to clean fan housing brackets and raise handle, fan housing, and fuel tank assembly up over engine and out of way.
17. Remove oil lines from each side of oil pump and from elbow on L.H. side of engine crankcases.
18. Remove the nut and washer from the stud extending through the chassis casting in front of the engine.
19. Loosen the magneto coupling.
20. Remove the bolts securing the engine to the chassis.
21. Slide engine back and away from the chassis.

CYLINDER RECONDITIONING

CYLINDER REMOVAL

1. Expose engine (Step 1-16 Engine Removal)



Fig. 13

4. Remove the four nuts and washers securing the cylinder to the crankcase.

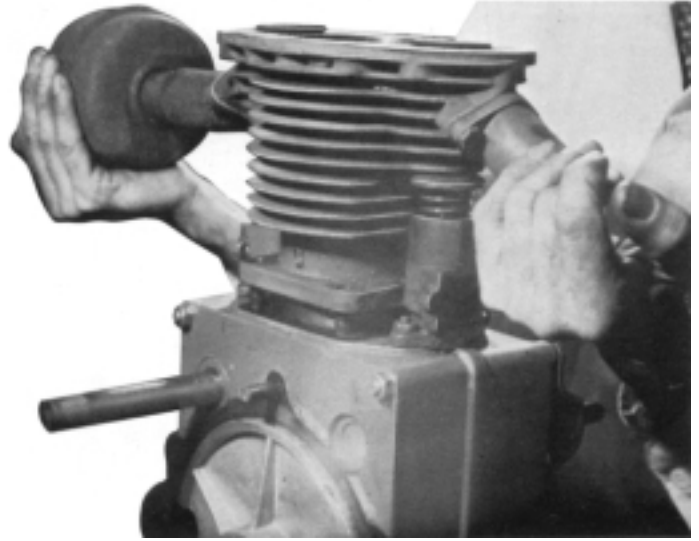

Figure 14

5. Lift the cylinder up off the crankcase and piston.

2. Remove cylinder head and gasket.
3. Loosen the nuts securing the valve guides to the crankcase.

RECONDITIONING

- A. Gasket surfaces
Check all surfaces to be sure that they are free of all gasket fragments and sealer materials. Surfaces must be free of scratches or nicks.
- B. Cylinder Bore
Diameter of standard cylinder is 3.2545 - 3.2535. Measure the cylinder bore at two points 90° apart at the top and bottom of the wear pattern to determine wear.

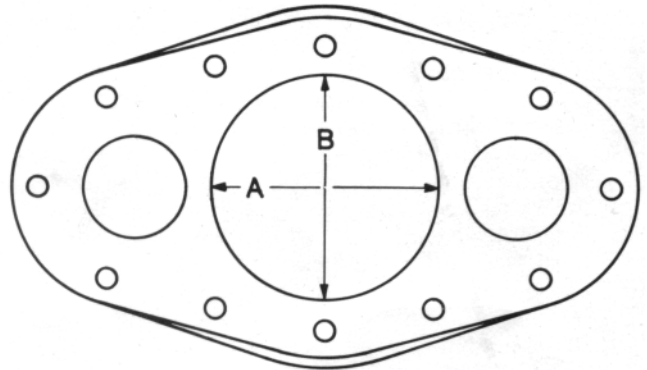

Figure 15

Bore Diameter	Piston Size	Ring Size
3.2545/3.2535	Std.	Std.
3.2625/3.2615	.005 oversize	.005 oversize
3/2675/3.2665	.010 oversize	.010 oversize
3.2725/3.2715	.015 oversize	.015 oversize
3.2775/3.2765	.020 oversize	.020 oversize
3.2825/3.2815	.025 oversize	.025 oversize
3.2875/3.2865	.030 oversize	.030 oversize

VALVES

ADJUSTMENT

Cold - intake .015
exhaust .015

VALVE REMOVAL

Remove cylinder from engine. See Cylinder Reconditioning steps 1-5.

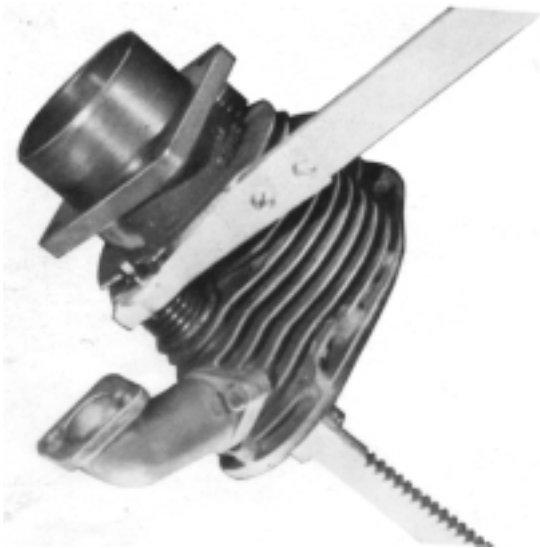

Figure 16

1. Support the cylinder in a vise.
2. Remove carburetor from the intake manifold.
3. Using a valve spring compressor, compress the valve spring and remove the valve spring key.

4. Release the valve spring compressor, and remove valve spring cap, valve spring and valve spring locator.
5. Remove valve from cylinder.
6. Repeat steps 3, 4, and 5 for other valve.

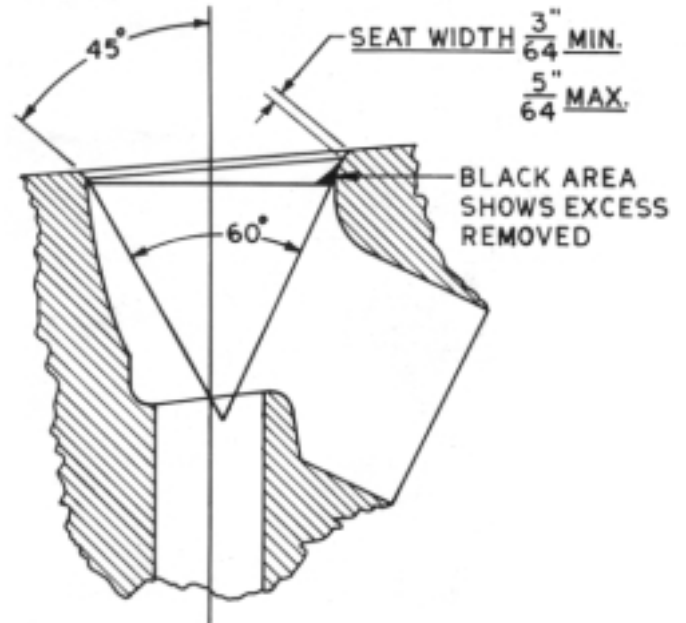

Figure 17

7. Grind valve seats at an angle of 45°. Be sure the seat is square with the valve guide bore. Grind seats to a dimension of 3/64 to 5/64. If the valve seat exceeds 5/64 on one side, use a 60° valve seat reamer to remove the excess valve seat width.

PISTON - RINGS

Pistons and rings are available in standard, .005; .010; .015; .020; .025 and .030 oversize. Be sure to use the correct rings with the correct pistons. Also, be sure the pistons and rings are correct for the rebored cylinder.

Never reuse old rings.

A new piston pin should be used with a new piston or rod. Always use new retainers even though you may be using the same piston and pin.

Piston is equipped with three rings.

- 1 Chrome Compression Ring
(Ring Gap: .012 to .020)
- 1 Steel Compression Ring
(Ring Gap: .088 to .016)
- 1 Oil Scraper Ring
Three Piece Chrome Oil Ring:
Ring (Gap .015 to .055)

The three-piece oil ring, should have from .015 to .055 end gap for the two flat segments. The top chrome compression ring should have .012 to .020 end gap. Measure the end gap with a feeler gauge, with the ring removed from the piston and held in the cylinder bore.

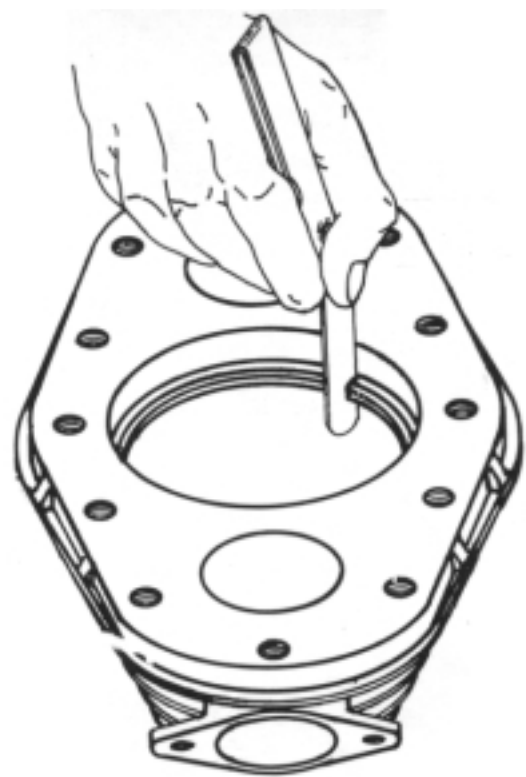

Fig. 18

FLYWHEEL ASSEMBLY

1. After removal of the cylinder, remove the valve guide - valveplunger assemblies from the crankcase.
2. Remove the fan drive pulley and woodruff key from the timing pinion shaft. Remove the set screw from the drive pinion bearing.
3. Remove the bolts holding the fan housing brackets to the crankcase.
4. Carefully polish the magneto shaft extension to remove all rust and paint.
5. Pry the crankcase halves apart, remove the flywheel assembly.
8. Remove the spreader bolt and nut.
7. Remove one flywheel using a two jawed gear puller or press.
8. Remove rod from crankpin and press the crankpin out of the other flywheel.

Carefully examine all parts for abnormal wear or damage. Check for damage also on the timing pinion shaft and the drive pinion shaft in the flywheels.

If a new rod is used, a crankpin must be used. If a new crankpin is used, a new rod must be used.

9. The grooved end of the crankpin is to be installed in the flywheel with the drive pinion shaft. Align the oil hole of the flywheel as near as possible to the hole in the groove of crankpin. Press the crankpin into the flywheel. The flywheel must be pressed tightly to the shoulder on the crankpin.
10. Place connecting rod on crankpin.
11. Align the flywheels as close as possible and press the remaining flywheel on the crankpin.
12. Install a *new* spreader bolt, washer and nut. Torque to 45 ft. lbs. Stake nut.

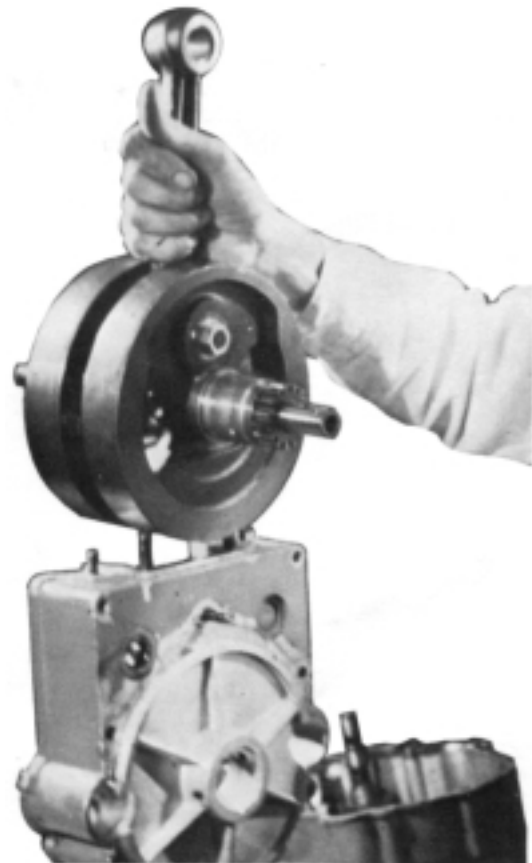

Fig. 19

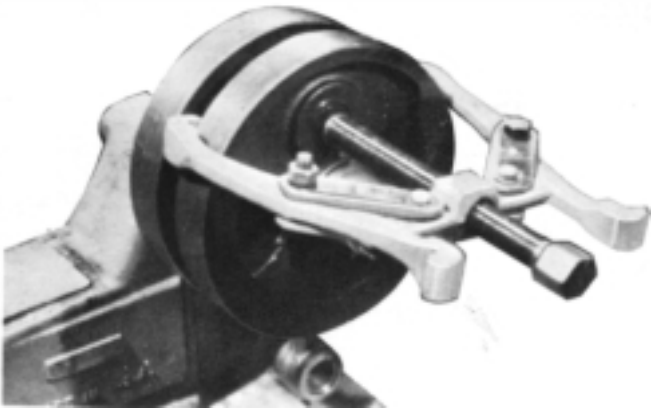

Fig. 20

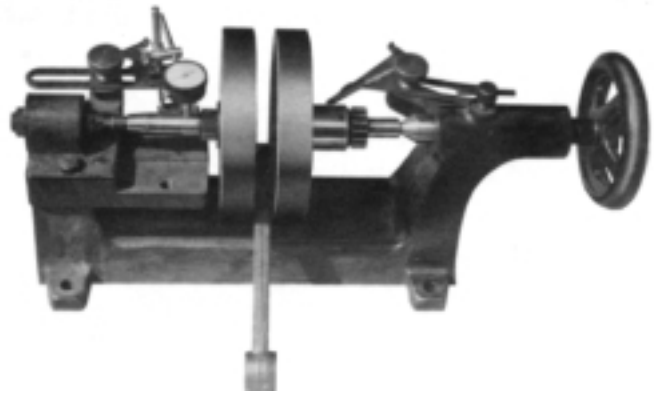

Fig. 21

13. Support ends of timing pinion shaft and drive pinion shaft between two centering spindles. Using a dial indicator check run out and balance flywheels to within .005 TIR.

CAMSHAFTS

CAMSHAFTS

To insure proper engine operation, accurate timing of the camshafts is necessary.

Each camshaft gear will have one timing mark on it and the idle gear has three ring marks on it.

Line up the mark on each camshaft gear with a timing mark on the idle gear. The other mark should be centered between the camshafts.

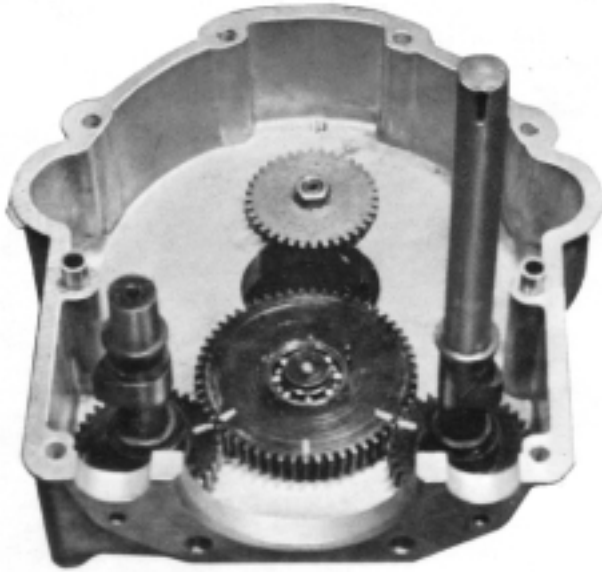

Fig. 22

CRANKCASE ASSEMBLY

1. With the rod at top dead center install the rod-flywheel assembly in the outer crankcase. Use care not to move the camshafts out of time.
2. Liberally apply Permatex #3 to the edges of the crankcase.
3. Remove the oil seals and expansion plug from the inner crankcase and place crankcase over camshafts and drive pinion shaft.
4. If not previously removed, remove the allen screw from the end of the drive pinion shaft.
5. Using the special Gravely Crankcase Assembly Puller, assemble the crankcase together. Install the setscrew in the inner crankcase against the drive pinion rearing
6. Unscrew the Crankcase Puller from the drive pinion shaft and reinstall allen screw in end of drive pinion shaft.
7. Install the fan housing brackets with the top bolts.
8. Check end play of the timing pinion bearing -should be .010-.020. If end play is in excess of this amount remove the bearing and pump body and install shims.
9. Using the oil seal protector and driver install new oil seals on the camshafts. Install new expansion plug.

ENGINE ASSEMBLY

1. Install the valve guide and plunger assemblies on each side of the crankcase, do not tighten.
2. Install a new gasket to the four studs on the crankcase.
3. Support the piston assembly and start the cylinder assembly down over the piston and rings.

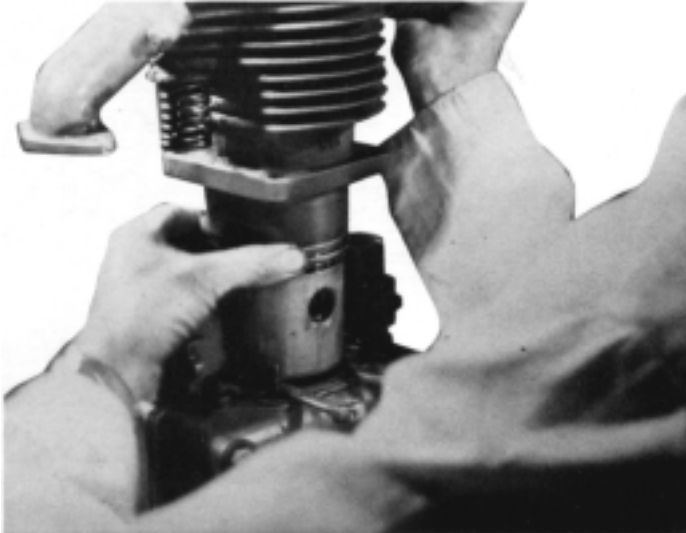

Figure 23

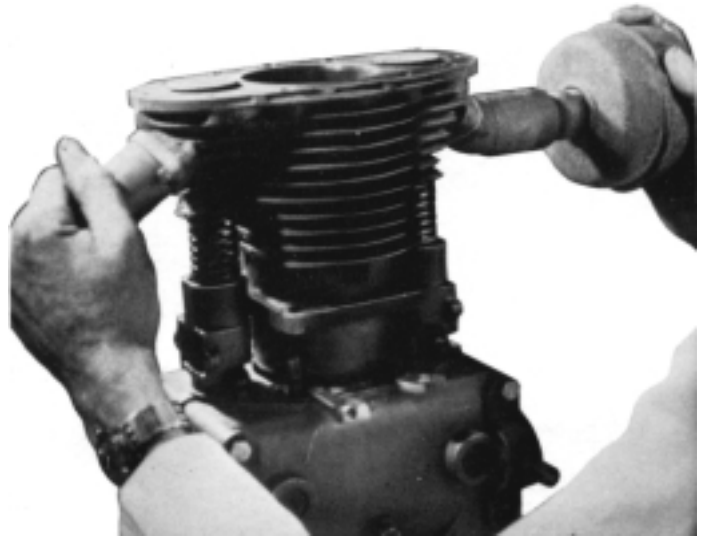

Figure 24

4. Guide the cylinder down over the piston guiding the valves and springs into the valve guides and the cylinder over the studs of the crankcase.
5. Secure the cylinder to the crankcase, tighten the valve guide assembly nuts.
6. Adjust the valve tappet clearance .012 inch; intake .012 inch exhaust.

ENGINE INSTALLATION

1. Slide engine in position on chassis.
2. Install six bolts securing the engine to chassis.
3. Install the washer and nut on the stud extending through the chassis casting in front of the engine.
4. Attach the intake and discharge lines to the oil pump. Connect the line to the side of the engine.
5. Lower handles, fuel tank and fan housing down over engine.
6. Position fan housing on studs of fan housing brackets.
7. Raise hitch and install hitch braces on fan housing bracket studs.
8. Install lockwashers and nuts on fan housing bracket studs.
9. Install R.H. air deflector.
10. Install magneto kill wire.
11. On swiftomatic tractors, connect the shifter rod to the shifter handle at the R.H. handle.
12. Attach the High-Low and Forward-Reverse controls to the R.H. handle.
13. Install fan belt.
14. Install LH air deflector.
15. Install carburetor on intake manifold.
16. Install air cleaner hose on carburetor and air cleaner mounting bracket.
17. Attach fuel line to carburetor and turn on fuel.
18. Connect throttle and choke controls to carburetor.
19. Time engine according to instructions on page 8



Fig. 25

20. Install head using new gasket. Torque bolts to 20 ft. lbs.
21. Install cylinder air deflectors.

TRANSMISSION TROUBLE ANALYSIS

TROUBLE	DETERMINATION	CAUSE	SOLUTION
Clutches engaged; Tractor drive wheels will not turn.		Bound linkage, missing clevis pins. Bent clutch rods, bent or broken actuating shaft levers.	Repair linkage.
	Engage P.T.O. and Hi-Lo planetary, P.T.O. does not turn.	Broken drive pinion shaft.	Replace parts as required.
	Engage P.T.O. and Hi-Lo planetary, P.T.O. does not turn, pinion shaft could be tight indicating broken parts in planetary	Hi-Lo planetary-gears broken, broken or worn clutch.	Replace parts as required
	Engage P.T.O. and Hi-Lo planetary, P.T.O. turns. Check differential action by raising wheels off the ground, turning one wheel by hand and other wheel should turn freely in opposite direction.	Forward-Reverse planetary - worn or broken clutches, broken gears.	Replace parts as required.
	Tight or no differential action. Free wheeling tractor or tractor wheels won't turn.	Differential problems.	Replace parts as required.
Transmission seems to be loading engine, even to stall point when Hi-Lo engaged. Ground speed about three times as fast as normal speed when Forward-Reverse is engaged.		Frozen Hi-Lo planetary	Replace parts as required
P.T.O. will not shift in or out of gear or will not stay in gear.		Binding of external linkage.	Repair external linkage.
		Broken or worn internal P.T.O. shifting mechanism.	Replace parts as required.

PTO

PTO

When internal PTO problems are suspected, remove the attachment or attachment cover plate and check the shifting mechanism.

If difficulties are noted, remove the shipper shaft/shipper shaft guide assembly. Carefully check all parts for excessive wear and/or damage.

If nothing abnormal is found, remove the attachment dog and pinion shaft. Check for wear or damage and check pinion shaft for twisting.

Check the thrust bushing assembly in the advance casting for wear or damage.

Carefully reassemble parts in proper sequence. Be sure a gasket is used under the shipper shaft guide.

FORWARD - REVERSE

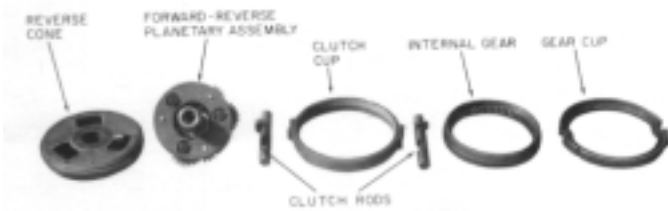

Figure 26

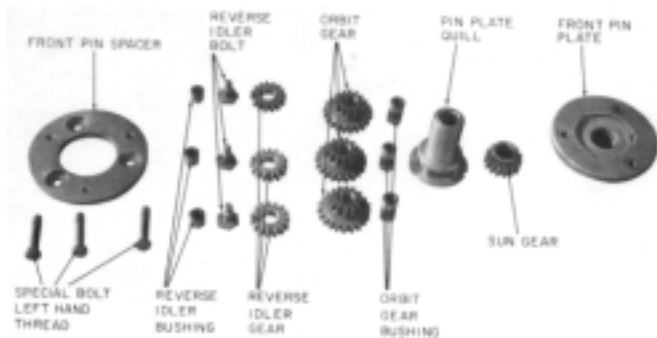

Figure 27

To gain access to the Forward-Reverse planetary, remove the attachment or attachment cover plate, PTO mechanism and the advance casting.

Rotate the actuating lever and release the planetary system. Carefully examine all parts for wear, excessive play or damage.

Before disassembling the planetary, check the fit of the gears on the pins. If gears appear too tight or too loose, disassemble the planetary and check the gears and pins for wear. (NOTE: Bolts have left hand threads) Assembly and time the planetary as follows:

1. Place the sun pinion in the bore of the front pin plate.
2. Secure the pin plate quill, over the sun pinion, to the pin plate with 3 -1/4 x 5/8 bolts.
3. Place orbit gear bushing in gears. Do not use old bushing in new gears or new bushing in old gears.

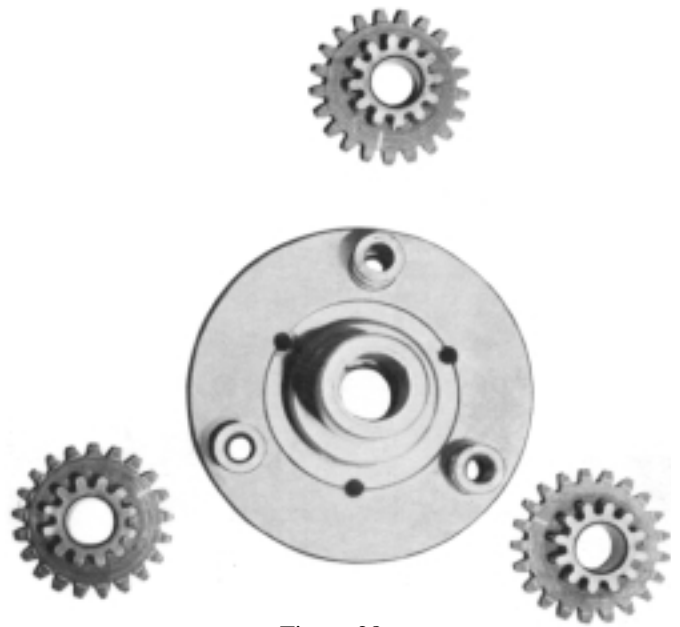

Figure 28

4. Mesh the three gears with the sun pinion so that the timing marks (punch mark on each gear) form an equal-sided triangle.
5. Secure the reverse idlers to the front pin spacer.
6. Secure the front pin spacer to the front pin plate using the special bolts.

When replacing this unit in the transmission, mesh the teeth of the actuating rod and clutch slide rods and slide the unit in position.

HIGH - LOW

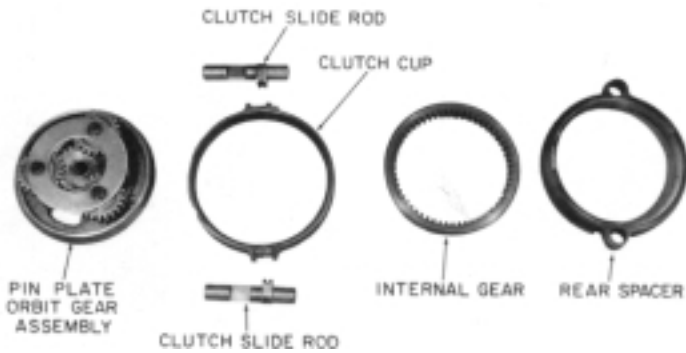

Figure 29

When internal high-low planetary problems are suspected, it is necessary to remove the engine as described on page 11.

Rotate the actuating lever to release the planetary system. Carefully examine parts for damage, abnormal or excessive wear.

Before disassembling the planetary, check the fit of the gears on the pins. If gears appear too loose or too tight, disassemble the planetary and check the gears and pins for scoring or abnormal wear.

It is necessary to time the planetary upon reassembly. Align the gears so the punch mark on the gears form an equal-sided triangle around the sun gear in the rear pin plate. Install the orbit pins, pin spacer and bolts. Check assembly by placing inside internal gear. The assembly should spin freely.

Place the clutch cup on the pin plate orbit gear assembly install internal gear rear spacer and clutch rods.

Reinstall in tractor, install engine.

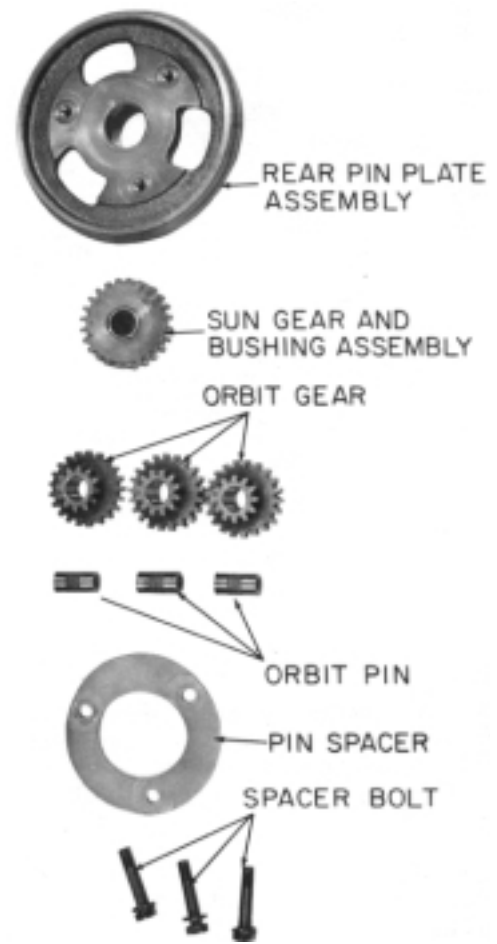

Figure 30

2 - SPEED DIFFERENTIAL

Before assuming internal differential problems, carefully check the external linkage. Check for binding, interference and be sure all parts are intact.

Check adjustment of shifting springs. The upper spring length when in low range should be 2 1/2 inches. The lower spring length when in high range should be 2 1/2 inches.

Check the adjustment of the toggle spring. It should be compressed to 15/16 inch.

Check the stationary clutch bolt for shearing and tightness. Torque to 45 ft. lbs.

To examine internally:

1. Remove R.H. wheel and wheel hub.
2. Disconnect swiftomatic shift linkage
3. Remove R.H. axle housing and axle.

The shifting yoke, shifting clutch, stationary clutch and clutch housing can now be inspected without further teardown. Carefully check that the stationary clutch

is in the proper position. Make sure that the sliding clutch slides freely on the shifting gear. If no discrepancies have been found at this point or if the failure is obviously a part of the differential assembly, disassemble further as follows:

1. Remove L.H. wheel and wheel hub.
2. Remove L.H. axle housing and axle.
3. Remove differential assembly. Check bearings, be sure they are not damaged and are pressed in position.
4. Secure the differential assembly upright in a vise with the shifting gear side up.

The following steps 5 to 12 refer to tractors serial numbers prior to J-65504. Refer to steps 13 to 24 for, tractors with serial numbers above J-65504.

5. Bend down locking tabs and remove six (6) bolts securing the clutch plate to the worm gear.

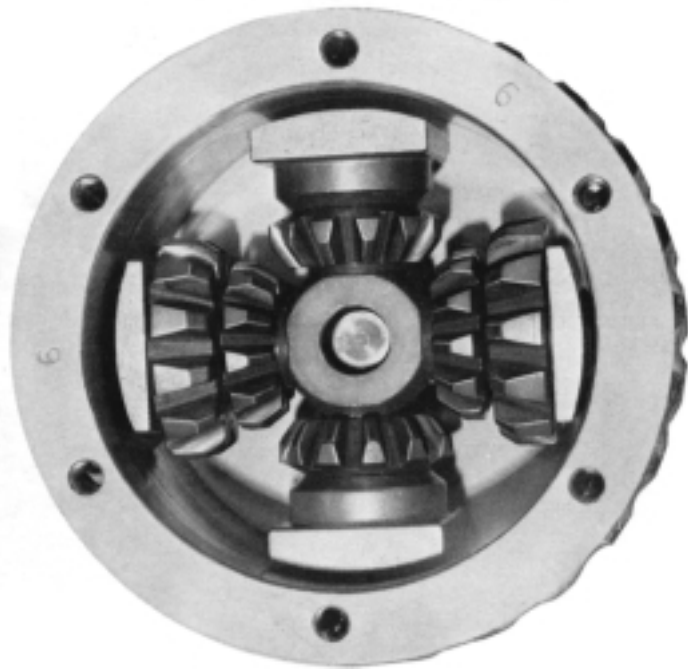

Fig. 31

6. Lift off clutch housing and remove shims.
7. Remove internal parts of differential mechanism. Carefully examine all parts for damage or abnormal wear. Check for scoring on back of shifting train pinion. Check the spider arms for scoring, check the bore of gears for scoring.
8. Examine the internal surface of the bronze gear for wear. An even wear pattern is normal. Check the pinned gear and differential gear for wear or damage.
9. Reassemble the differential mechanism, using new thrust bearings, if any other parts are replaced. Assemble on two opposite spider arms, in this sequence, spider gear, shifting train pinion, needle thrust bearings, needle thrust race, shims, then spider thrust washer. On two remaining spider arms, assemble in this sequence, spider gear and thrust spacer. Install in bronze gear.
10. Using a differential gear, check shimming of spider gears. Adjust shims so that gear sits solid on all four spider gears.
11. Install shims, differential gear, shifting gear and clutch housing on worm gear. Install bolts using new locking plates. Torque to 20 ft. lbs.
12. Check end play of shifting gear .0 - .010 maximum. If necessary, remove clutch housing and adjust shims accordingly. Reinstall clutch housing, bolts and locking plates. Torque to 20 ft. lbs. Secure locking plates to bolts. Gears should turn freely.
13. Using wire cutters, remove wire securing bolts from each side of worm gear.
14. Secure differential assembly in a vise, shifting gear side up.
15. Remove bolts securing clutch housing to worm gear, remove clutch plate, gears and shims.
16. Turn worm gear over and remove pinned housing and gears.
17. Tilt differential mechanism and remove from worm gear. The mechanism does not ride on the inside surface of the gear.
18. Disassemble the differential mechanism- carefully check the bore of the gears and the spider arms for scoring check the backs of the shifting train pinions.

19. Reassemble the differential mechanism using new thrust needle bearings if any other parts were replaced. On the two spider arms with snap ring grooves at the end, assemble in this sequence, spider gear, shifting train pinion, bearing, spacer and snap ring. On the other two arms assemble in this sequence: spider gear, race, bearing, spacer and snap ring.
20. Tilt the differential mechanism and install it in the worm gear.
21. Install the pinned gear and differential gear on the pinned housing and install it on the worm gear. Torque bolts to 20 ft. lbs.
22. Turn worm gear over and install the clutch housing, with differential gear, shifting gear and shims on the worm gear. Torque bolts to 20 ft. lbs.
23. Check end play of shift gear .00 - .010 maximum. Remove clutch housing and adjust shims as necessary. Torque bolts to 20 ft. lbs.
24. Insert wire through one bolt head, cross and insert through other, then twist ends together securely. Trim twist to 1/2 inch length. Repeat, securing other bolts. Repeat on bolts on other side of gear.
25. Install differential on L.H. axle in L.H. axle housing. (Pinned housing side of differential assembly in axle housing.) Be sure thrust pin is in place in the differential assembly so it will be between the axles.
26. Place equal amount of shims and a shellacked gasket on each axle housing. Install L.H. axle housing and differential assembly in tractor. Secure axle housing to tractor.
27. Install R.H. axle housing on tractor, being sure the shifting clutch fits on the shifting gear. Secure axle housing to tractor. Torque bolts to 45 ft. lbs.



Fig. 32

28. Remove the engine and high-low planetary or the advance casting and the forward-reverse planetary. Using a screwdriver or similar tool, check the differential assembly for play. Running clearance should be .008-.012. Adjust by adding or removing an equal amount of shims from each axle housing. Adjust axles for .008-.012 end play. Add or remove shims behind the bearing cap.

STANDARD DIFFERENTIAL

Removal

1. Raise tractor and remove wheels.
2. Drain tractor transmission of oil.
3. Remove axle and housing.
4. Remove differential assembly.



Fig. 33

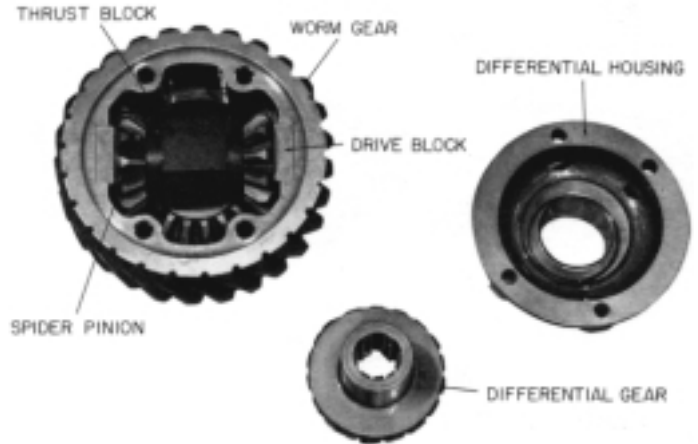

Fig. 34

Carefully check the bearings and gears for wear or damage. Replace excessively worn or damaged parts.
Reassembly differential back in tractor using an equal amount of shims on each axle housing.
Torque axle housing bolts to 45 ft. lbs.
Refill the differential with 5 pints of oil of proper viscosity. Replace oil filter if damage was found in the transmission.

TORQUE VALUES - STANDARD HARDWARE ITEMS

SIZE	TORQUE
1/4 - 20	70 in. lbs.
1/4-20	85 in. lbs.
5/16-18	150 in. lbs.
5/16-24	165 in. lbs.
3/8-16	260 in. lbs.
3/8 - 24	300 in. lbs.
7/16 -14	35 ft. lbs.
7/16 - 20	45 ft. lbs.

SIZE	TORQUE
1/2 - 13	50 ft. lbs.
1/2 - 20	70 ft. lbs.
1/2 - 12	75 ft. lbs.
1/2 - 18	100 ft. lbs.
5/8-11	110 ft. lbs.
5/8 -18	140 ft. lbs.
3/4 -10	150 ft. lbs.
3/4 - 16	200 ft. lbs.

CONVERSION TABLE (INCH LBS. TO FOOT LBS.)

FOOT LBS.	5	10	15	20	25	30	35	40	45	50
INCH LBS.	60	120	180	240	300	360	420	480	540	600

Divide inch lbs. by 12 for foot pound values.

Multiply foot lbs. by 12 for inch pound values.

SPECIFICATIONS and TORQUES

Cylinder Head Bolts	20 ft. lbs.
Spark Plug Gap	.025"
Breaker Point Gap	.015"
Compression	70 - 80 psi
Engine RPM (Max.)	2600 - 2800
Oil Pump Cap Bolts	80 in lbs.
Cylinder Diameter (Std.)	3.2545" - 3.2535"
Timing Pinion Shaft	90 ft. lbs.
Drive Pinion Shaft	90 ft. lbs.
Forward - Reverse Planetary Spacer Bolt	30 ft. lbs.
Pen Plate Quill Bolt	80 in. lbs.
Axle Bearing Cap Bolt	12 ft. lbs.

Valves - Intake	.015
Valves - Exhaust	.015
Spreader Bolt	45 ft. lbs.
Stationary Clutch Bolt	45 ft. lbs.
Swiftamatic Bolts	20 ft. lbs.
Axle Housing Bolts	45 ft. lbs.
Point Resistance	0 ohm
Primary Coil Winding	.5 - 1 ohm
Secondary Coil Winding	5,000 - 8,000 ohm