

GRAVELLY OPERATOR'S MANUAL

NAME: CART - TWO WHEEL TRACTOR

PART NUMBER(S): 22172



The Cart is for use with the Gravely Two Wheel tractors.

The coupler strut weldment kit (part number 11980) and the trailing hitch kit (part number 11627) are needed to connect the cart to the tractor.

All reference to right side, left side, front and rear are given from the operator's position.

To continue its program of quality and design improvement, the manufacturer reserves the right to change specifications, designs and prices without notice and incurring obligation.

Form No. 31969 (8-79)

Printed in U.S.A.



CONTENTS

1.0	Warnings - For Your Safety
1.1	Instructions Before Operating
1.2	Preparation For Operation
1.3	Operation
2.0	How to Connect the Cart to the Tractor
3.0	How to Disconnect the Cart from the Tractor
4.0	How to Operate the Cart
4.1	How to Steer the Tractor from the Cart
4.2	How to Dump the Load from the Cart
5.0	How to Do Maintenance
5.1	How to Tighten the Bolts
5.2	How to Lubricate the Cart
6.0	How to Put the Cart in Storage
7.0	Illustrated Parts and Parts List

1.0 WARNINGS - FOR YOUR SAFETY

NOTE: This warning symbol  indicates that there is danger to persons or equipment. Read these warnings carefully and follow them.

This section gives warnings for you about operating and doing maintenance on this equipment.

Using this equipment the wrong way can cause injury to persons and damage to the equipment. Persons operating or doing maintenance on this equipment must read this Operator's Manual and follow the instructions.

It is important to understand that this Operator's Manual and other Gravely instruction books do not list every possible danger. It is not possible for Gravely to know and tell of all the dangers in operating and doing maintenance on the equipment.

The purchaser must give these instructions to the person operating and doing maintenance on this equipment. The purchaser must get the operator and person doing maintenance on this equipment to use eye and foot protection.

1.1 Instructions Before Operating

1. Read this Operator's Manual and the Operator's Manual for the tractor carefully before operating or doing maintenance.
2. Learn the location and the function of all the tractor controls.
3. Know how to use the controls to stop the tractor quickly.
4. Never permit children to operate or ride on the tractor or the cart.

5. Use caution with gasoline. Gasoline is very flammable. Keep gasoline in a clean and tight container. Keep gasoline away from fire or hot items. Never put gasoline in the fuel tank while the engine is running or hot. Clean any leakage of gasoline from the tractor before starting the engine.

1.2 Preparation For Operation

1. Check the area of operation and remove all material that will be hit by the tractor or the cart.
2. Make sure all shields and guards are in the correct position before operating.
3. Wear strong shoes. Wear clothing that is not loose. Wear eye protection.
4. Before starting the engine, put the direction control lever in the "NEUTRAL" position and the power take off (PTO) control in the "OUT" position.
5. Keep the tractor and the cart in good operating condition. Do the maintenance as shown in this Operator's Manual.
6. Do not operate the tractor and the cart where the area of operation is too dark for the operator to see.
7. Never operate the tractor or the cart when there is damage to any part or when any part is not in the correct position.

1.3 Operation

1. Keep away from moving parts.
2. Keep all persons and animals away from the area of operation.
3. Do not let persons other than the operator ride on the tractor or the cart.
4. Disconnect the cart before operating on slopes. Do not operate the cart on slopes.
5. Use the hitch on the tractor to connect the cart. Do not change the hitch or try to use a different hitch for the cart.

6. Always look for and keep away from holes and other hazards.
7. Use caution when moving backwards. Hold the handlebars firmly. Look for persons and hazards in the way.
8. When dumping the load, be sure that everyone is clear of the cart and the load.
9. After hitting an object, stop the tractor and the engine and check for damage. If there is damage, make repairs before restarting.
10. Operate the equipment only when in the operator's position.
11. Put the PTO control in the "OUT" position before leaving the tractor. Turn the ignition switch to the "OFF" position and remove the ignition key.
12. If there is a sudden change in the sound or vibration of the tractor or the cart, stop the tractor and check for damage. If there is damage, make repairs before operating.
13. Never start and run the engine inside a building except to move the equipment outside. Exhaust fumes are dangerous.
14. Always follow traffic laws while going on or near a road.
15. Go slow on surfaces where the tractor can slide.
16. Put the PTO control lever in the "OUT" position before leaving the operator's position to make adjustments or to do maintenance. Turn the ignition switch to the "OFF" position. Wait until the engine and the moving parts have stopped.

2.0 HOW TO CONNECT THE CART TO THE TRACTOR

⚠ WARNING: Stop the engine of the tractor before connecting the cart to the tractor.

1. Fasten the coupler strut to the drawbar of the cart with the 1/2" x 3-1/2" bolt and the 1/2" lock nut as shown in figure 2.0-1.

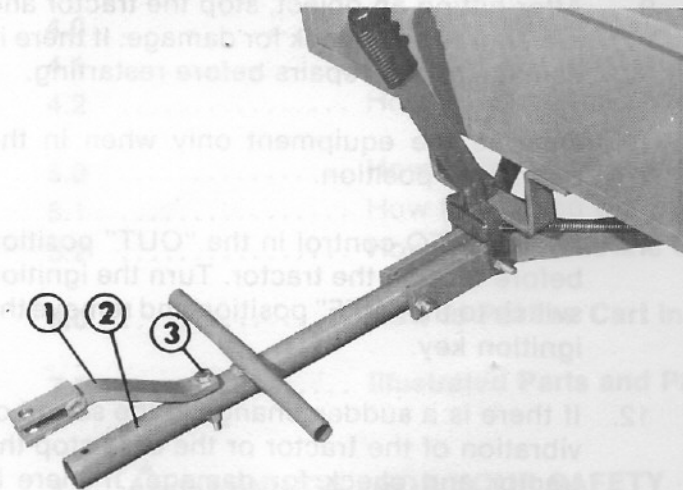

1 - Coupler Strut
2 - Drawbar
3 - 1/2" x 3-1/2" Bolt

Figure 2.0-1

2. Install a 5/8" nut on the ball stud. Put the ball stud in the bottom hole of the tractor hitch with the ball down. Install the other 5/8" nut on the ball stud and tighten. See figure 2.0-2.

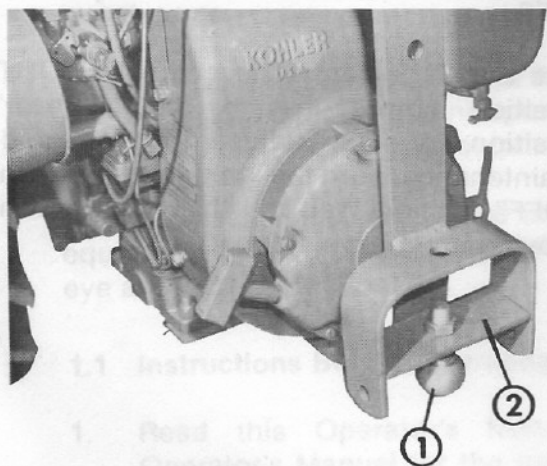

1 - Ball Stud
2 - Tractor Hitch

Figure 2.0-2

3. Put the split socket around the ball stud and hold it. Put the split socket into the drawbar of the cart. See figure 2.0-3.

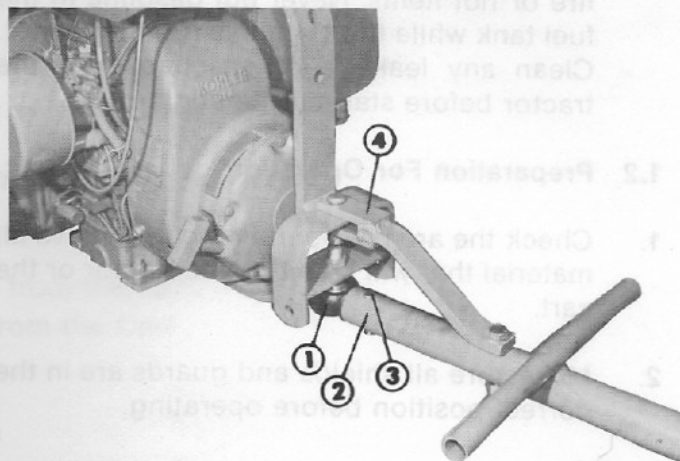

1 - Split Socket
2 - Drawbar
3 - Clevis Pin
4 - Coupler Strut

Figure 2.0-3

4. Put the clevis pin in the hole of the drawbar and install the hair pin cotter. See figure 2.0-3.
5. Fasten the coupler strut to the top of the tractor hitch with the clevis pin and the cotter pin. See figure 2.0-3.

3.0 HOW TO DISCONNECT THE CART FROM THE TRACTOR

⚠ WARNING: Stop the engine of the tractor before disconnecting the cart from the tractor.

1. Remove the cotter pin and the clevis pin from the coupler strut.
2. Remove the hair pin cotter and the clevis pin from the drawbar of the cart.
3. Pull the drawbar from the split socket.
4. Fasten the clevis pin to the coupler strut with the cotter pin.
5. Insert the split socket into the drawbar and install the clevis pin and the hair pin cotter.

4.0 HOW TO OPERATE THE CART

Read this Operator's Manual and the Operator's Manual for the tractor before operating the equipment.

4.1 How to Steer the Tractor from the Cart

WARNING: Use a slow speed the first time you operate the tractor and the cart. Use a slow speed when turning.

WARNING: Do not operate the cart on slopes or rough ground.

1. Start the engine of the tractor. Wait until the engine is running smoothly before operating.

WARNING: To prevent injury, the operator must be on the seat with both feet on the footrest while operating the tractor and the cart.

Move the throttle to the "FAST" position.

3. Put the direction control lever in the "FORWARD" position.
4. Hold firmly to the handlebars and push the handlebar to the right to steer to the left.
5. Hold firmly to the handlebars and push the handlebar to the left to steer to the right.

4.2 How to Dump the Load from the Cart

WARNING: Stop the engine of the tractor. Do not operate the tractor when dumping the load from the cart.

WARNING: The load in the cart must not be heavier than the weight of the tractor (500 pounds, 227 kg.). Do not carry tall objects or high stacked loads.

1. Remove the seat from the cart.
2. Lift the tailgate. See figure 4.0-1.

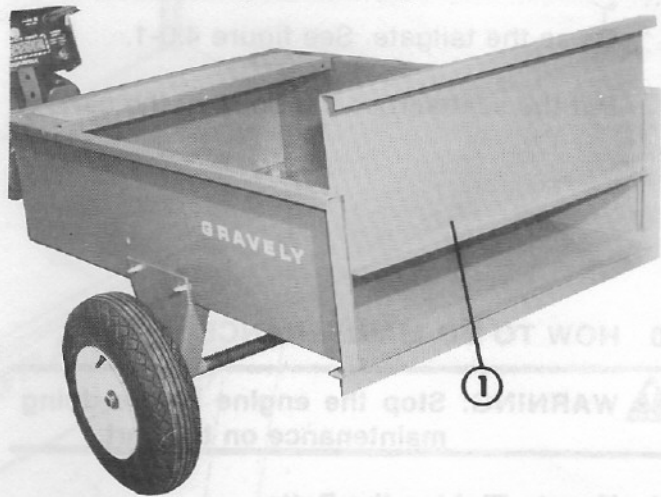

1 - Tailgate

Figure 4.0-1

WARNING: To prevent injury, be sure everyone is clear of the cart and the load when dumping.

3. Pull the handle to the front to unlock the latch and lift the front of the cart. See figure 4.0-2.

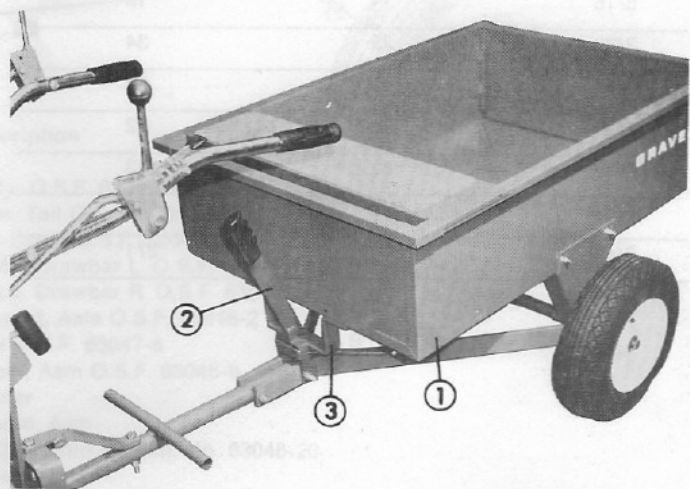

1 - Body
2 - Handle
3 - Latchbar

Figure 4.0-2

4. Push the body of the cart down at the front. Push the handle to the rear of the cart to lock the latchbar.

WARNING: Make sure the body is in the locked position.

5. Close the tailgate. See figure 4.0-1.
6. Put the seat across the body of the cart.

5.0 HOW TO DO MAINTENANCE

WARNING: Stop the engine before doing maintenance on the cart.

5.1 How to Tighten the Bolts

Inspect all bolts, nuts, and other fasteners to make sure they are tight. Replace any fasteners that are missing. Tighten the bolts to the torque shown in figure 5.0-1, unless given differently.

BOLT TORQUE SPECIFICATIONS

BOLT SIZE	FOOT POUNDS (ft. lbs.)	NEWTON METERS (N.m)
1/4"	7	9.5
5/16"	14	19
3/8"	25	34
7/16"	40	54
1/2"	60	82
9/16"	83	113
5/8"	120	163
3/4"	200	271

Figure 5.0-1

5.2 How to Lubricate the Cart

Every eight hours of operation do the following:

1. Clean around the grease fittings on the wheels. See figure 5.0-2.

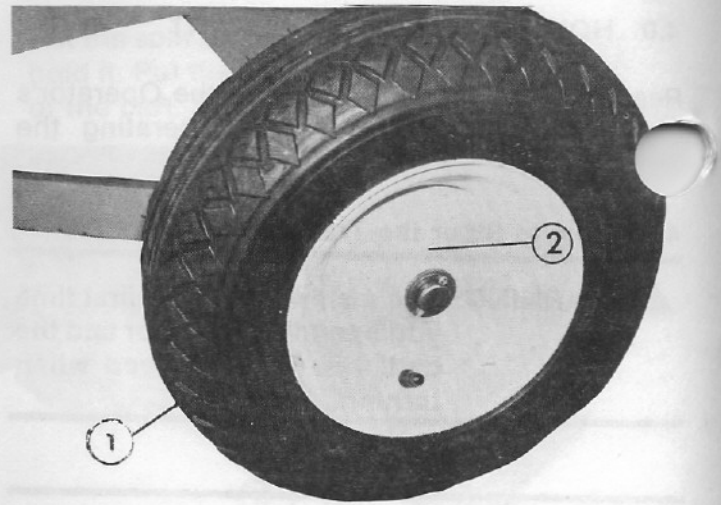

1 - Wheel
2 - Grease Fittings

Figure 5.0-2

2. Put multi-purpose grease in the grease fittings on the wheels until grease shows around the wheel bearings. See figure 5.0-2.
3. Clean the grease from around the grease fittings and from the outside of the wheel bearings. See figure 5.0-2.
4. Put six drops of engine lubricant on each side of the latch handle pivot.

6.0 HOW TO PUT THE CART IN STORAGE

If the cart will not to be used for three months or more, do the following:

1. Clean all debris and dirt from the cart.
2. To prevent rust, apply paint or lubricant to any area where the paint has been removed.
3. Do the maintenance shown in section 5.0.

7.0 ILLUSTRATED PARTS AND PARTS LIST

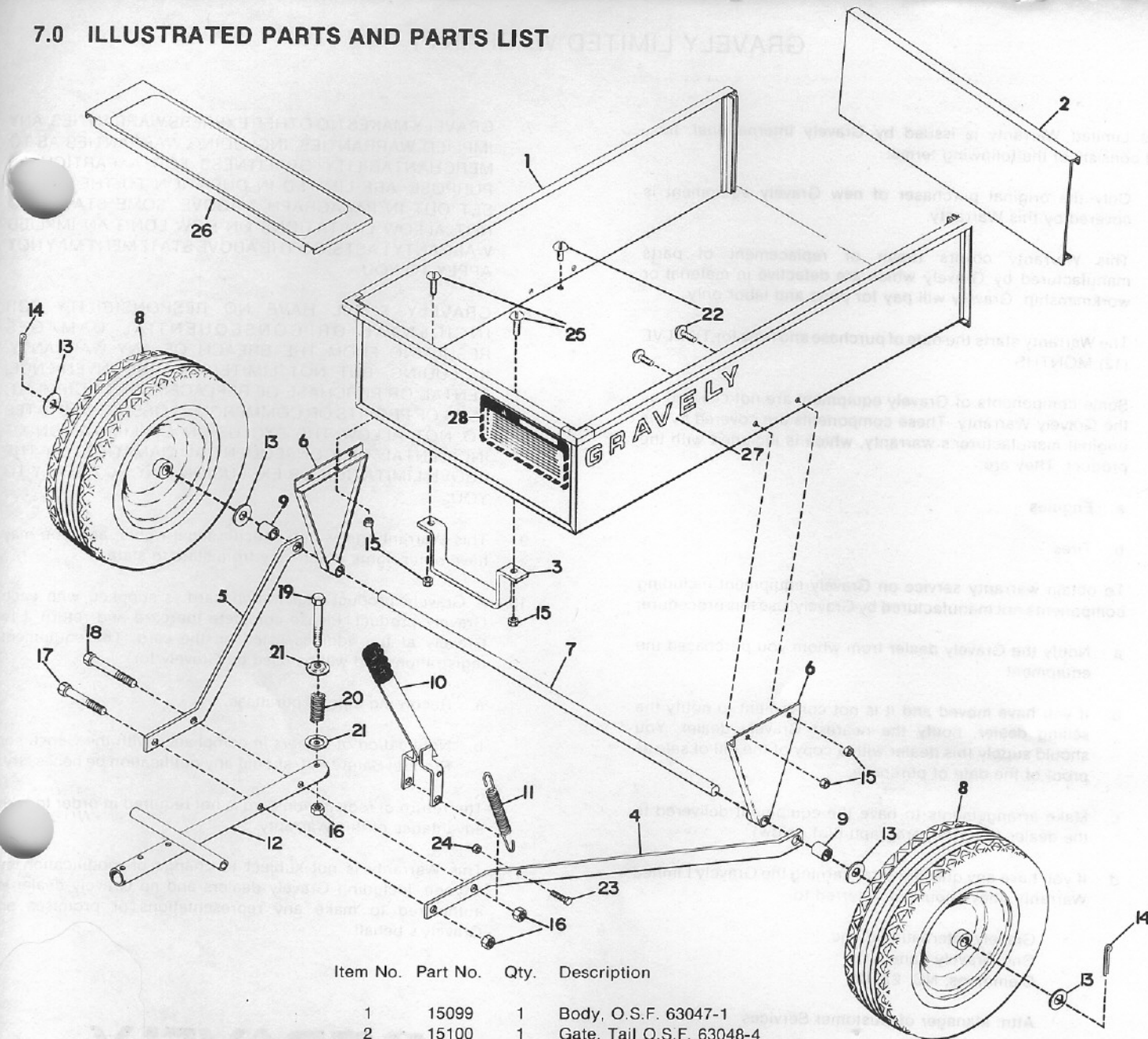

Item No.	Part No.	Qty.	Description
1	15099	1	Body, O.S.F. 63047-1
2	15100	1	Gate, Tail O.S.F. 63048-4
3	15101	1	Bar, Latch O.S.F. 62047-13
4	15102	1	Brace, Drawbar L O.S.F. 63047-11
5	15103	1	Brace, Drawbar R O.S.F. 63047-10
6	15104	2	Support, Axle O.S.F. 63048-2
7	15105	1	Axle O.S.F. 63047-6
8	15106	2	Wheel, Asm O.S.F. 63048-9
9	15107	2	Spacer
10	15108	1	Handle, Asm
11	15109	1	Spring, Ohio Stl Fab. No. 63048-20
12	15216	1	Drawbar
13	131019	4	Washer, Flat; 1.062 x 2.000 x .134
14	137253	2	Pin, Cotter; 3/16 x 1-5/8
15	120377	8	Nut, Hex; 3/8-16
16	120378	3	Nut, Hex; 1/2-13
17	180192	1	Bolt, Hex; 1/2-13 x 3-1/2
18	433156	1	Bolt, Hex; 1/2-13 x 4.50
19	180194	1	Bolt, Hex; 1/2-13 x 4.00
20	12613	1	Spring, Valve
21	12738	2	Locator, Valve Spring
22	160776	6	Screw, Mach; 3/8-16 x 3/4 Pan HD
23	180022	1	Bolt, Hex; 1/4-20 x 1.00
24	120375	1	Nut, Hex; 1/4-20
25	160825	2	Screw, Mach; 3/8-16 x 1 Pan HD
26	15111	1	Seat, O.S.F. 63048W-12
27	19365	1	Decal, Gravely White Vinyl
28	20934	1	Decal, Warning

GRAVELY LIMITED WARRANTY

This Limited Warranty is issued by Gravelly International, Inc., and consists of the following terms:

1. Only the original purchaser of new Gravelly equipment is covered by this Warranty.
2. This Warranty covers repair or replacement of parts manufactured by Gravelly which are defective in material or workmanship. Gravelly will pay for parts and labor only.
3. The Warranty starts the date of purchase and lasts for TWELVE (12) MONTHS.
4. Some components of Gravelly equipment are not covered by the Gravelly Warranty. These components are covered by the original manufacturer's warranty, which is included with the product. They are:
 - a. Engines
 - b. Tires
5. To obtain warranty service on Gravelly equipment including components not manufactured by Gravelly, use this procedure:
 - a. Notify the Gravelly dealer from whom you purchased the equipment.
 - b. If you have moved and it is not convenient to notify the selling dealer, notify the nearest Gravelly dealer. You should supply this dealer with a copy of the bill of sale as proof of the date of purchase.
 - c. Make arrangements to have the equipment delivered to the dealer (refer to paragraph 6(a) below).
 - d. If you have any questions concerning the Gravelly Limited Warranty, they should be referred to:

Gravelly International, Inc.
One Gravelly Lane
Clemmons, NC 27012

Attn: Manager of Customer Services

- e. Warranty service on Gravelly equipment must be performed by an authorized Gravelly dealer or Gravelly factory branch.
6. This Warranty does not cover the following:
 - a. Transportation between owner's home or place of business and the dealership. If the dealer provides the transportation of the equipment, he will charge the owner his usual rate for such service.
 - b. Normal maintenance services and normal replacement of items such as spark plugs, belts, oil, oil filters, air filters, and mower, plow or cultivator blades.
 - c. Alterations or Modifications - All obligations under this warranty shall be terminated if the equipment is altered or modified in any way.
 - d. Customer Neglect or Lack of Proper Maintenance - The purchaser is responsible for making sure that the tractor is operated and serviced as directed in the operator's manual. Incorrect use or maintenance will void the warranty.

7. GRAVELLY MAKES NO OTHER EXPRESS WARRANTIES. ANY IMPLIED WARRANTIES, INCLUDING WARRANTIES AS TO MERCHANTABILITY OR FITNESS FOR A PARTICULAR PURPOSE, ARE LIMITED IN DURATION TO THE SET OUT IN PARAGRAPH 3 ABOVE. SOME STATES DO NOT ALLOW LIMITATIONS ON HOW LONG AN IMPLIED WARRANTY LASTS, SO THE ABOVE STATEMENT MAY NOT APPLY TO YOU.
8. GRAVELLY SHALL HAVE NO RESPONSIBILITY FOR INCIDENTAL OR CONSEQUENTIAL DAMAGES RESULTING FROM THE BREACH OF ANY WARRANTY, INCLUDING, BUT NOT LIMITED TO, INCONVENIENCE, RENTAL OR PURCHASE OF REPLACEMENT EQUIPMENT, LOSS OF PROFITS OR COMMERCIAL LOSS. SOME STATES DO NOT ALLOW THE EXCLUSION OR LIMITATION OF INCIDENTAL OR CONSEQUENTIAL DAMAGES, SO THE ABOVE LIMITATION OR EXCLUSION MAY NOT APPLY TO YOU.
9. This Warranty gives you specific legal rights, and you may have other rights which vary from state to state.
10. A Gravelly product registration card is supplied with each Gravelly product. Please complete the card and return it to Gravelly at the address listed on the card. The equipment registration card will be used by Gravelly for:
 - a. Recording date of purchase.
 - b. Notification of owners in compliance with the Consumer Product Safety Act, should any notification be necessary.The return of registration card is not required in order to take advantages of this Warranty.
11. This Warranty is not subject to change or modification by anyone, including Gravelly dealers and no Gravelly dealer is authorized to make any representations or promises on Gravelly's behalf.

 **GRAVELLY**