



**BOOT KIT
FOR
60" CENTER MOUNT MOWER
&
60" PRO MASTER MOWER**

FORM NO: 45582(7-88)

PART NO: 45580, 45581

PRINTED IN USA
\$1.00

SECTION 1

INSTALLATION INSTRUCTIONS

NOTE: This kit is designed to be used on 60" Center Mount Mowers, part number 45790 or later and 60" Pro Master Mowers, part number 45405 or later. This kit can be used on an older 60" Pro Master Mower, but only after the deck is reworked as instructed in Section 1.1. If the boot kit is to be used on a mower not requiring rework, proceed to Section 1.2.

1.1 Reworking the 60" Pro Master Mower:

1. Remove the discharge chute bracket from the mower deck and cut off the portion of the bracket which is represented by the shaded area in Figure 1.
2. Install the 60" Mower Roller & Scroll Kit on the deck. Follow Steps 1 through 5 in the instructions included in that kit. Reinstall the lift pivot bracket and rear adjustment plates as instructed in Step 6 in that manual. Reinstall the discharge chute bracket on the deck using one of the 3/8-16x1.00 round head square neck bolts, flat washers and lock nuts previously removed.
3. Drill one .406 diameter hole through the bracket and the deck, approximately .50 inches from the edge of the bracket as shown in Figure 1. Install a 3/8-16x1.00 hex bolt, flat washer and lock nut in the new hole.

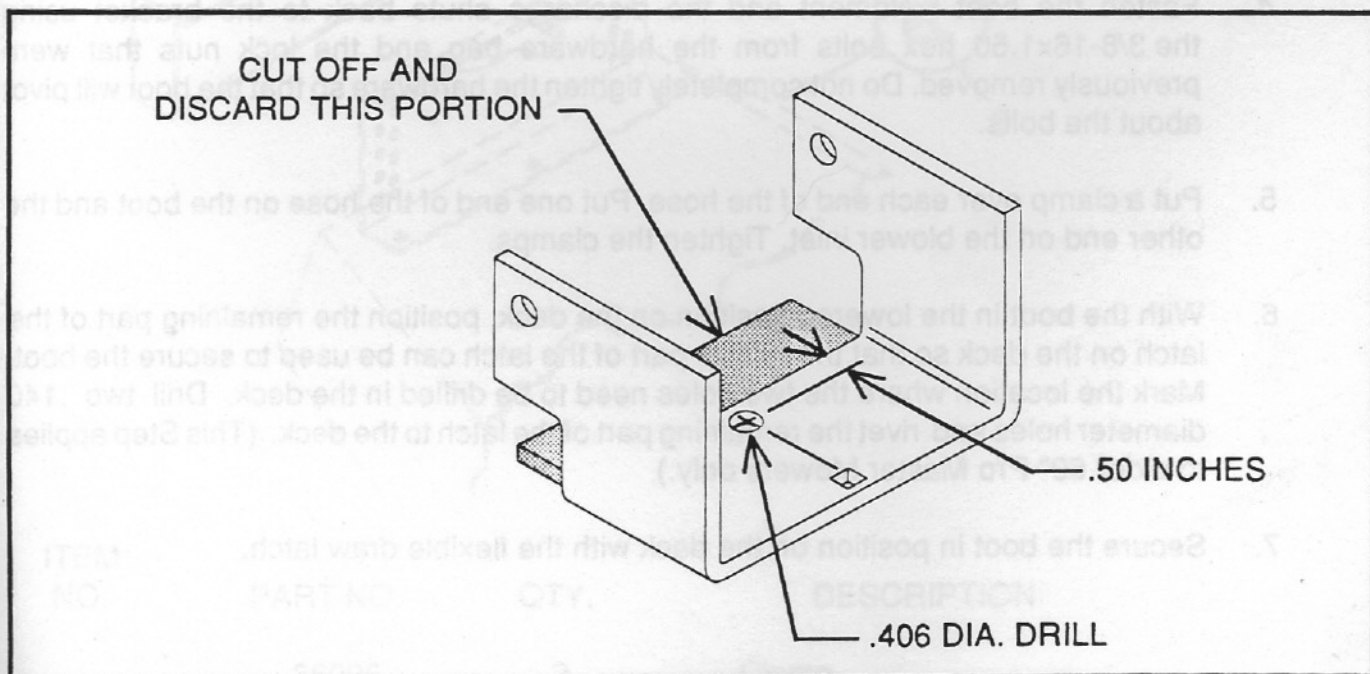

FIGURE 1

1.2 Installing the Boot Weldment:

1. Remove the boot kit from the shipping container.

NOTE: The boot kit is to be used in conjunction with the hinged discharge chute. When the boot is removed, the hinged discharge chute must be installed. The boot can be used while the hinged discharge chute is mounted and in the raised position. After the boot is removed, the hinged discharge chute must be lowered before mowing.

2. Rivet one part of the flexible draw latch to the deck and the other part to the boot weldment as shown in the illustration.

NOTE: On older 60" Pro Master Mowers, the two holes needed in the deck for fastening a part of the latch must be drilled. Follow the instructions in Steps 3 through 5 and then drill the holes as instructed in Step 6.

3. Remove the 3/8-16 hardware that fastens the discharge chute to the discharge chute bracket on the deck.
4. Fasten the boot weldment and the discharge chute back to the bracket using the 3/8-16x1.50 hex bolts from the hardware bag and the lock nuts that were previously removed. Do not completely tighten the hardware so that the boot will pivot about the bolts.
5. Put a clamp over each end of the hose. Put one end of the hose on the boot and the other end on the blower inlet. Tighten the clamps.
6. With the boot in the lowered position on the deck, position the remaining part of the latch on the deck so that the rubber part of the latch can be used to secure the boot. Mark the location where the two holes need to be drilled in the deck. Drill two .140 diameter holes and rivet the remaining part of the latch to the deck. (This Step applies to older 60" Pro Master Mowers only.)
7. Secure the boot in position on the deck with the flexible draw latch.

SECTION 2

ILLUSTRATED PARTS AND PARTS LISTS

60" Center Mount Mower

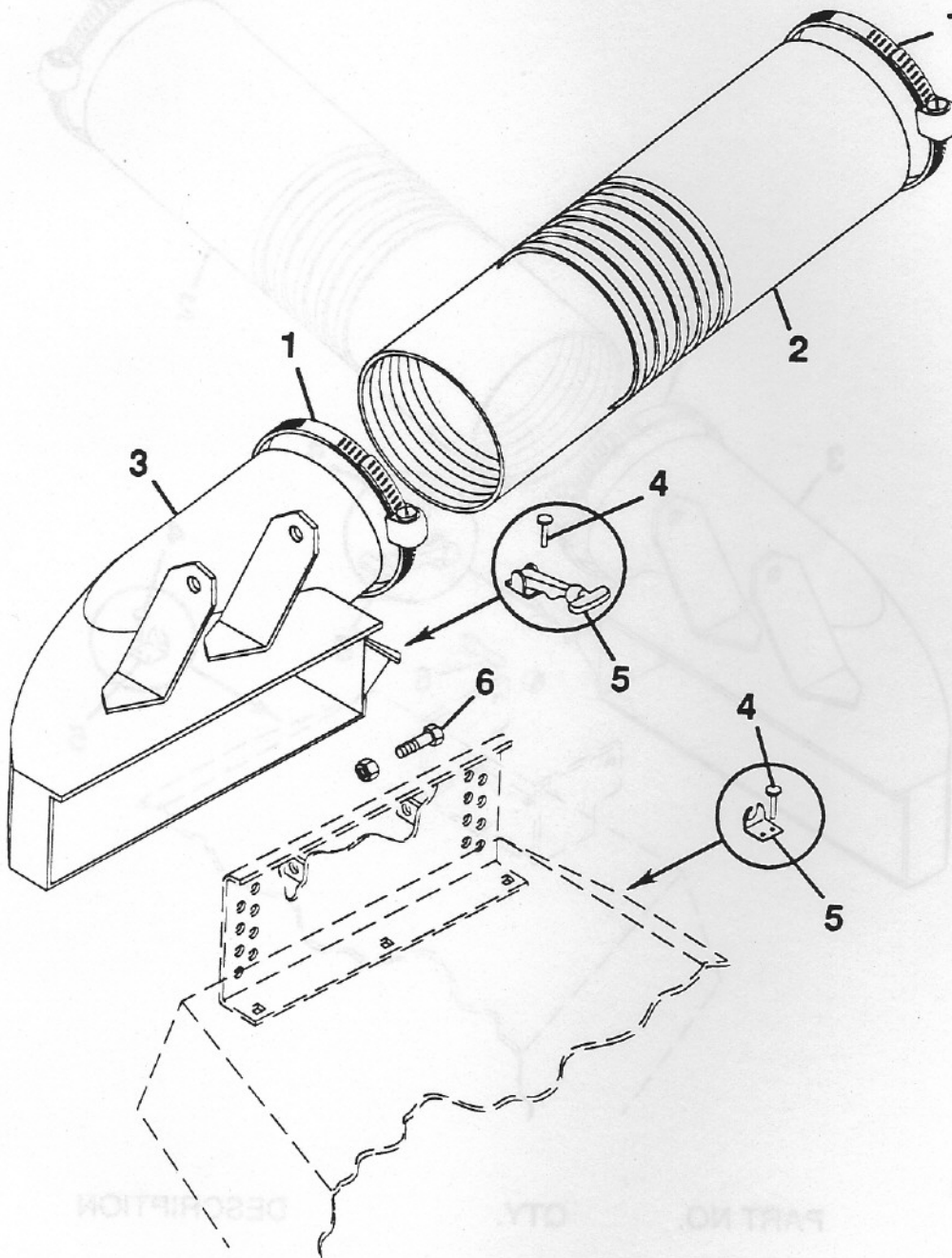

ITEM NO.	PART NO.	QTY.	DESCRIPTION
1	36996	2	Clamp
2	42234	1	Hose, Mower to Blower
3	45553	1	Weldment, 60" Boot
4	45545	4	Rivet, Dome Head
5	41553	1	Latch, Flexible Draw
6	180126	2	Bolt, Hex 3/8-16x1.50

60" Pro Master Mower

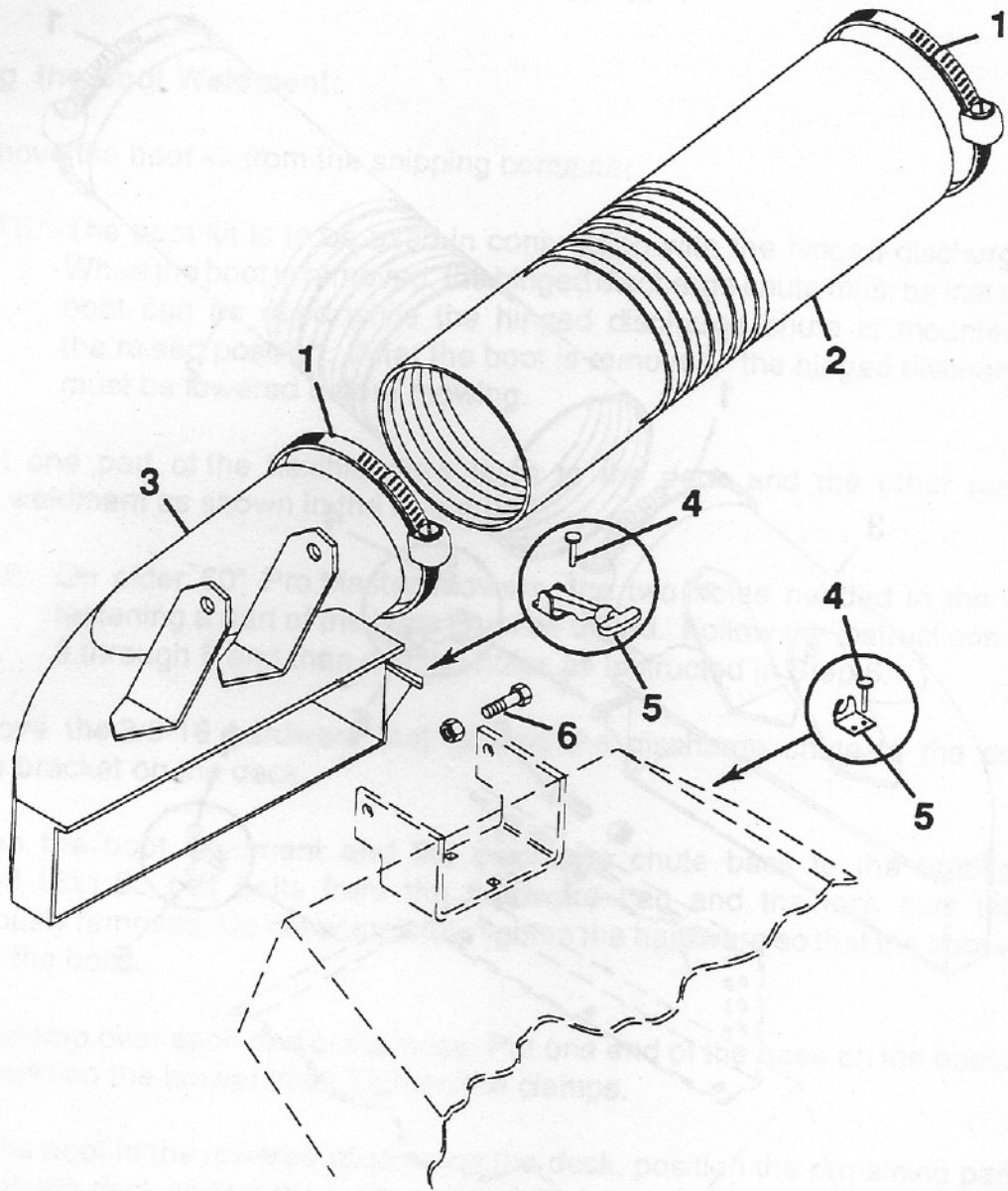

ITEM NO.	PART NO.	QTY.	DESCRIPTION
1	36996	2	Clamp
2	36986	1	Hose, Mower to Blower
3	45553	1	Weldment, 60" Boot
4	45545	4	Rivet, Dome Head
5	41553	1	Latch, Flexible Draw
6	180126	2	Bolt, Hex 3/8-16x1.50