

GRAVELY[®]

810

812

814

816

OWNERS

MANUAL



THANK YOU for your investment in Gravely equipment. It is an investment, for the Gravely will save you work and worry for many years.

You will gain still greater satisfaction from your powerful Gravely if you add the tools you need for your other jobs. From time to time we suggest you consult our catalog for the many Gravely attachments that will eliminate grounds upkeep and garden drudgery.

Numerous independent dealers and factory branches distribute Gravely equipment. All are ready to give prompt and efficient service, with parts in stock and personnel trained in factory-service methods.

Your Gravely tractor and attachments are warranted under terms shown herein. To qualify for this Warranty, you must register your equipment by completing the attached Registration Card and returning it. For your own protection, please do this right away.

To continue its program of quality and design improvement, the manufacturer reserves the right to change specifications, design or prices without notice and without incurring obligations.

SAFETY SPECIFICATIONS

1. Know the controls and how to stop quickly – READ THE OWNER'S MANUAL.
2. Do not allow children to operate vehicle. Do not allow adults to operate it without proper instructions.
3. Do not carry passengers. Keep children and pets a safe distance away.
4. Clear work area of objects which might be picked up and thrown.
5. Disengage all attachment clutches and shift into neutral before attempting to start engine.
6. Disengage power to attachments and stop engine before leaving operator position.
7. Disengage power to attachments and stop engine before making any repairs or adjustments.
8. Disengage power to attachments when transporting or not in use.
9. Take all possible precautions when leaving vehicle unattended; such as disengaging power take-off, lowering attachments, shifting into neutral, setting parking brake, stopping engine and removing key.
10. Do not stop or start suddenly when going uphill or downhill. Mow up and down the face of steep slopes; never across the face.
11. Reduce speed on slopes and in sharp turns to prevent tipping or loss of control. Exercise extreme caution when changing direction on slopes.
12. Stay alert for holes in terrain and other hidden hazards.
13. Use care when pulling loads or using heavy equipment.
 - A. Use only approved drawbar hitch points.
 - B. Limit loads to those you can safely control.
 - C. Do not turn sharply. Use care when backing.
 - D. Use Wheel weights when suggested in owner's manual.
14. Watch out for traffic when crossing or near roadways.
15. When using any attachments never direct discharge of material toward by-standers nor allow anyone near vehicle while in operation.
16. **Handle gasoline with care — it is highly flammable.**
 - A. Use approved gasoline container.
 - B. Never remove cap or add gasoline to a running or hot engine or fill fuel tank indoors. Wipe up spilled gasoline.
 - C. Open doors if engine is run in garage — exhaust fumes are dangerous. Do not run engine indoors.
17. Keep vehicle and attachments in good operating condition and keep safety devices in place.
18. Keep all nuts, bolts and screws tight to be sure equipment is in safe working condition.
19. **Never store equipment with gasoline in the tank inside of building where fumes may reach an open flame or spark.**
20. Allow engine to cool before storing in any enclosure.
21. To reduce fire hazard keep engine free of grass, leaves or excessive grease.
22. Vehicle and attachments should be stopped and inspected for damage after striking a foreign object and the damage should be repaired before restarting and operating the equipment.
23. Do not change engine governor settings or overspeed engine.
24. When using vehicle with mower:
 - A. Mow only in daylight or in good artificial light.
 - B. Never make a cutting height adjustment while engine is running if operator dismounts to do so.
 - C. Shut engine off when unclogging chute.
 - D. Check blade bolts for proper tightness at frequent intervals.

TABLE OF CONTENTS

Safety Specifications	2
Introduction	3
Routine Maintenance	4
Controls	7
Operation	8
Rear Hitch	9
Center-Mount Attachments	10
Front-Mount Attachments	11
Four Bolt Mounting Attachments	12
Trailing Attachments	13
Rear Mount Attachments	13
Axle Mount Attachments	15
Specifications	16
Warranty	16

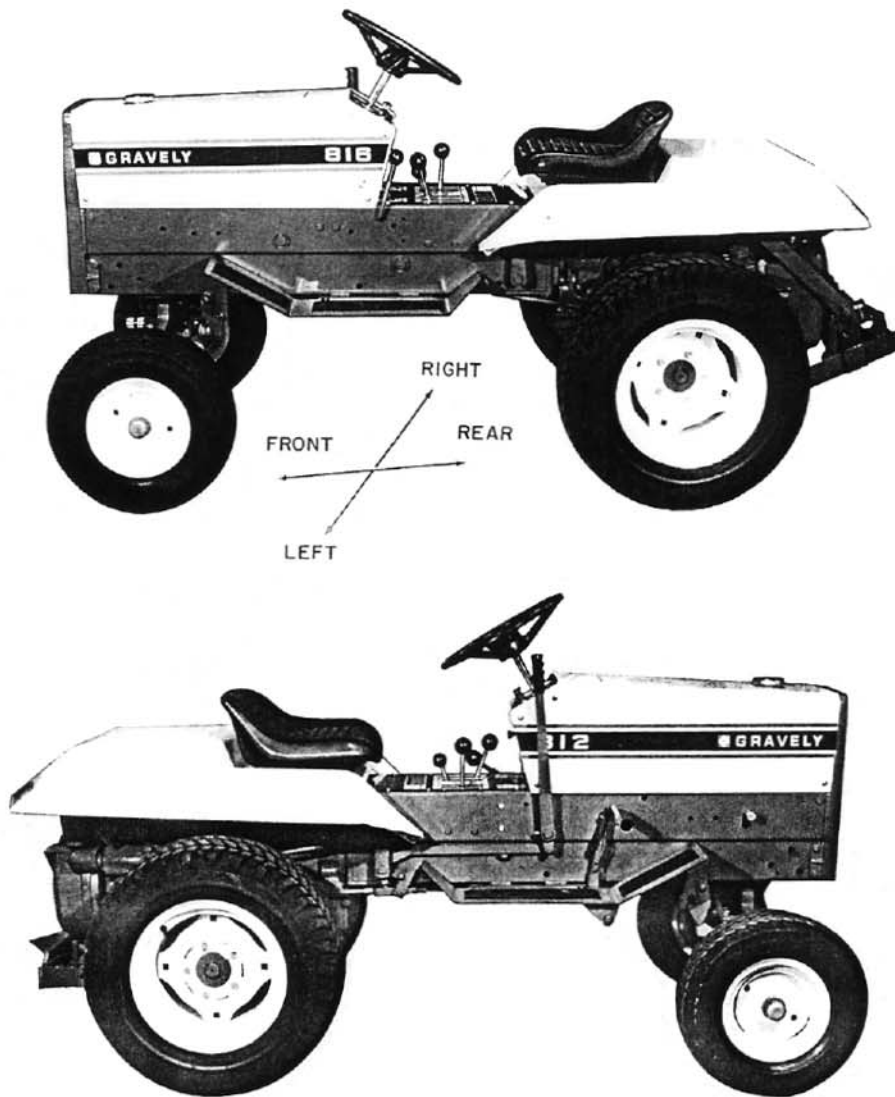

INTRODUCTION

Your new Gravely tractor will give you long years of highly satisfactory performance if maintained and operated as outlined in this manual.

It is important that you know the serial number of your tractor. It is located in the motor mount plate just in front of and below the air cleaner, and is 163334.

It is also important that you know the model number, serial number and specification number of the engine. They are located on the engine name plate on the left hand side of the engine shrouding.

Engine Model Number K3018

Engine Serial Number 5024437

Engine Specification Number 47482 d

Any correspondence concerning your tractor should contain these numbers to expedite prompt response to your needs.

To continue its program of quality and design improvement, the manufacturer reserves the right to change specifications, design or prices without notice and without incurring obligations.

ROUTINE MAINTENANCE

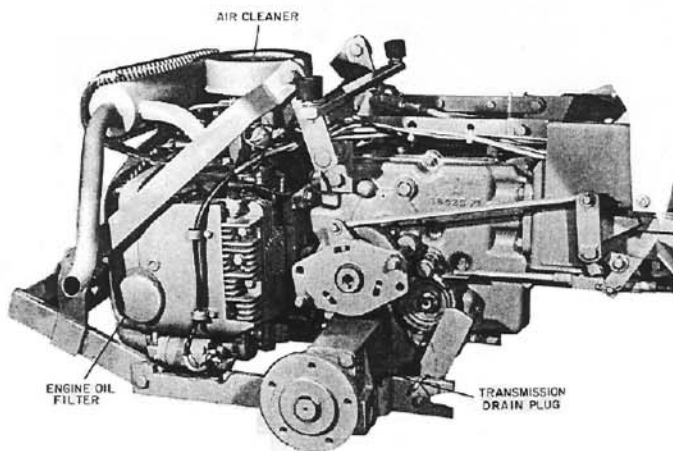

Figure 2

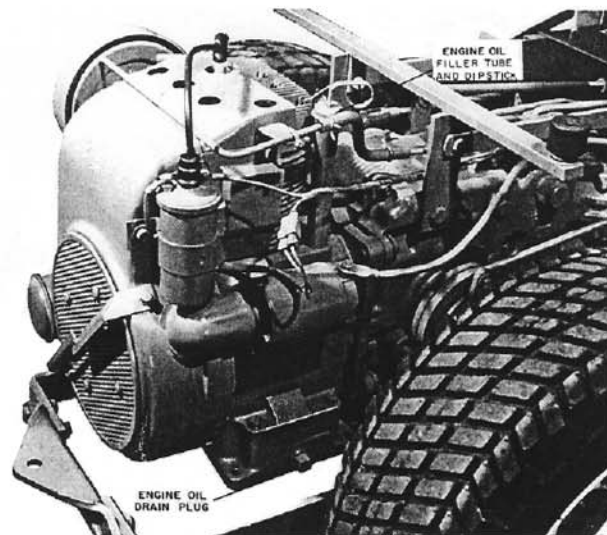

Figure 4

TRANSMISSION – (All models)

Capacity— 6 U. S. Quarts

Use SAE 30 API classification SC or SD oil for year round use. Check level only upon evidence of leakage. Level should be at level plug.

Drain plug is on the right side of the transmission near the bottom of the transmission case.

Engine (810,812,814)

Capacity – 5 U. S. Pints

Use API classification SC or SD oils

Summer – SAE 30

Winter – SAE 5 W20

Check oil level daily. Maintain at full mark. Do not overfill. Change oil every 25 hours or oftener under dusty conditions. Drain plug is on the right side of the engine base.

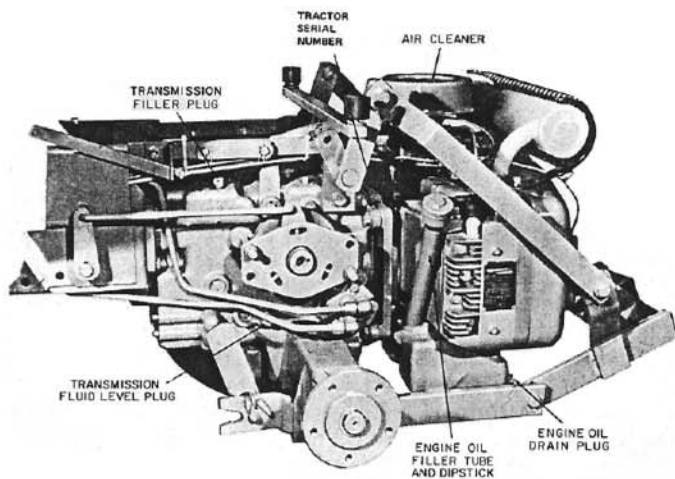

Figure 3

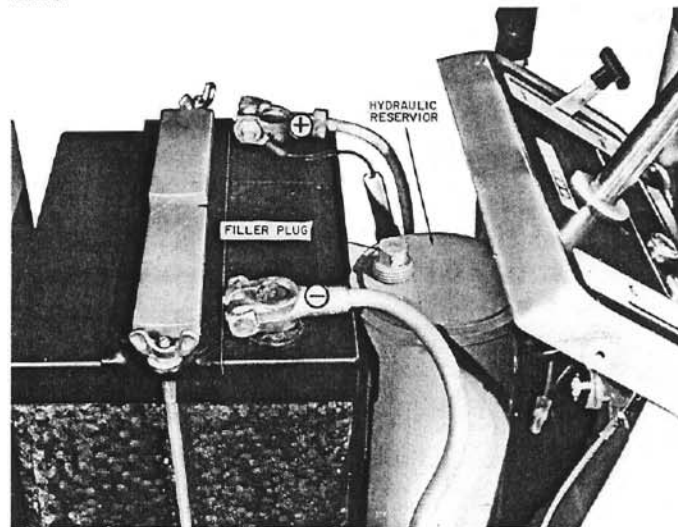

Figure 5

Engine (816)

Capacity – 4 U. S. pints

Use API classification SC or SD oils

Summer – SAE 30

Winter – SAE 5 W20

Check oil level daily. Maintain at full mark. Do not overfill. Change oil after initial 5 hours of operation and then every 40 hours or oftener under dusty conditions.

Change oil filter every 200 hours or oftener under dusty conditions.

Drain plug is on the engine base at the rear left hand corner.

Attachment Lift (Hydraulic Lift Models)

Do not run tractor without fluid in the hydraulic system.

Capacity – 1½ U. S. Quarts

Use only Type A Suffix A Automatic Transmission Fluid such as Shell Donax T-6 or Gulf Dexron Automatic Transmission fluid.

Check fluid level every oil change. Use care when checking fluid level. Do not allow dirt to enter the hydraulic system.

Maintain level at full mark on dipstick.

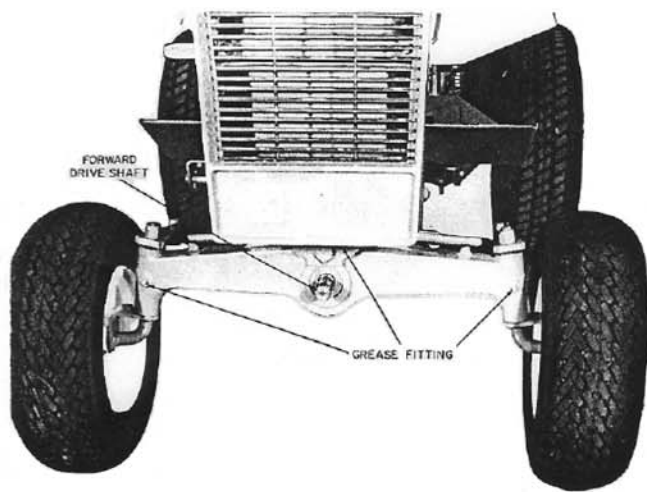

Figure 6

Greasing

These are four (4) grease fittings on a tractor. Grease with general purpose grease every eight (8) hours.

King Pin Weldments - 2

Axle Pivot Pin - 1

Direction Control Lever - 1

Any time the tractor is washed or "hosed off", it should be greased to force any moisture out of the bearings.

If the tractor is operated with the tractor wheels in water above the front wheel bearings, the front wheel bearings should be repacked with wheel bearing grease.

Periodic light oiling of pivot points of linkage aids operation.

Air Cleaner

Clean or replace when necessary. A loss of power is an indication that air cleaner service is required.

Do not clean the element with compressed air or wash the element.

The air cleaner element should be cleaned by gently tapping on a flat surface.

Replace the element if it is bent, crushed or damaged in anyway, or if the dirt does not fall off readily.

When reinstalling, be sure the element fits the adapter plate and the wing nut is finger tight.

Tires

Proper tire pressure is 12-18 psi. Check regularly and maintain at proper pressure.

Battery

Regularly check electrolyte level. Maintain at proper level by adding distilled water.

Clearances	810,812,814	816
Spark plug gap (in)	.025	.025
Intake valve (in)	.008-.010	.010-.012
Exhaust valve (in)	.017-.020	.010-.012

Forward-Reverse Clutches

Gap - .020-.030 inch (Even gap all around)

Readjust clutches when gap exceeds .050." Adjust by tightening nuts on studs.

Be sure nuts are tightened equally.

MEASURE THIS DISTANCE

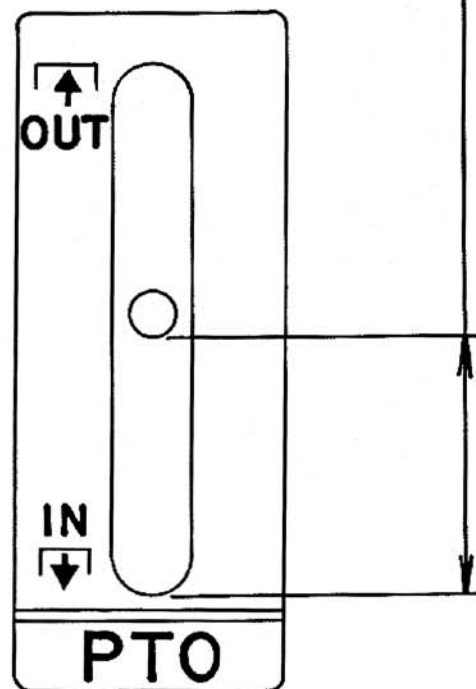

Figure 7

PTO Clutch

It is necessary that the PTO lever have free travel. If the free travel is too great, the clutch will not disengage and if the free travel is too little, the clutch will activate too hard and operation will be affected. With the PTO lever engaged (IN position) there should be 1 3/8 to 1 1/2 inches of free travel between the lever and the back of the slot in the cover plate.

When the free travel reaches on (1) inch, adjust the clevis on the PTO rod until there is 1 3/8 to 1 1/2 inches of free travel of the lever again.

NOTE: When operating the tractor a powered attachment, engage the PTO to increase oil circulation within the transmission.

CONTROLS

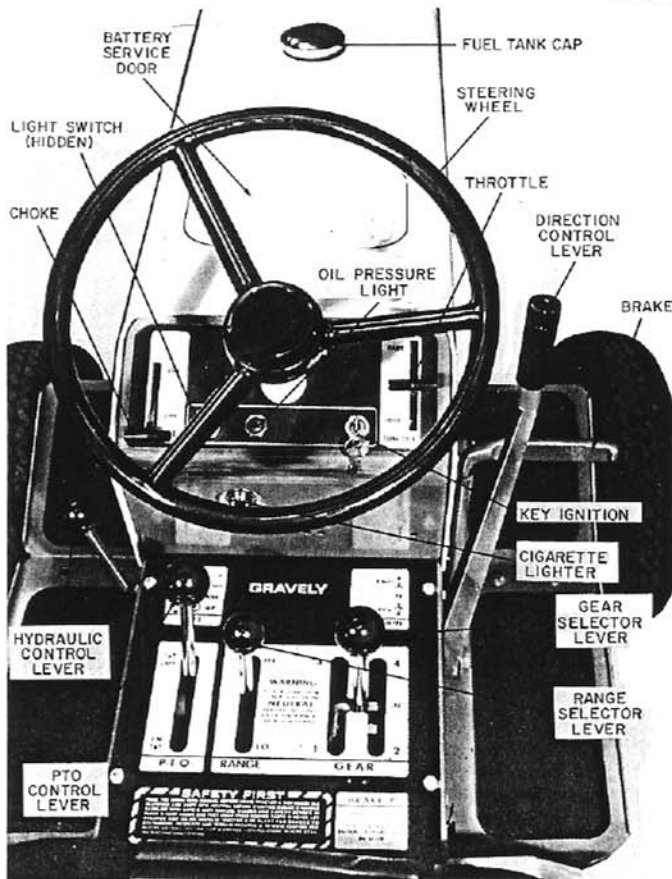

Figure 8
Hydraulic Lift Models

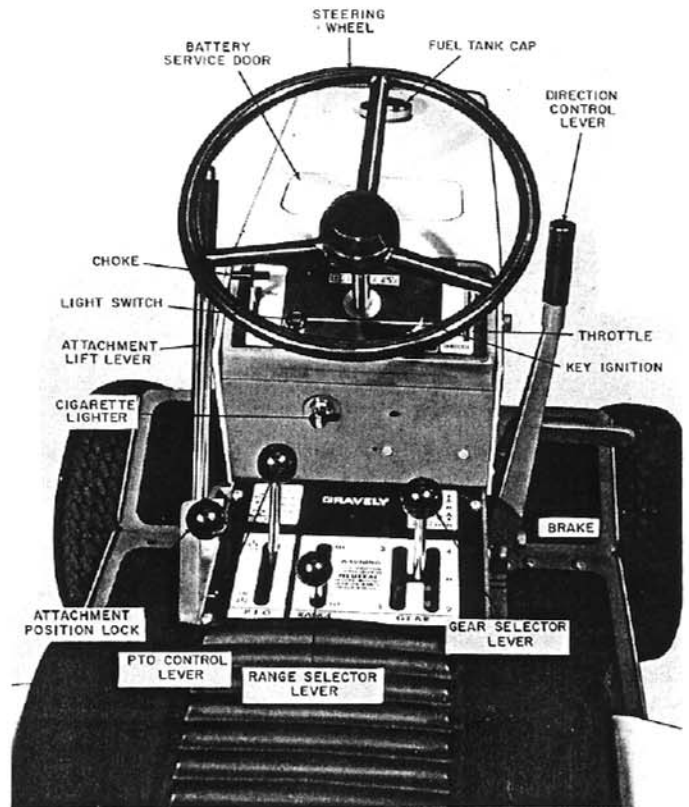

Figure 9
Manual Lift Models

1. Fuel Tank Cap – open to fuel tank, capacity – 5.3 gallons. Use high quality, regular grade gasoline.
2. Steering Wheel – turn steering wheel in the direction you wish to go.
3. Throttle – controls engine speed.
4. Oil Pressure Light (816 only) – indicated low oil pressure. If oil pressure light should come on while in operation, stop tractor immediately and check oil level. Add oil, if necessary. If oil level is not low, call your dealer or see your engine service manual.
5. Direction Control Lever – push away from you to go forward, pull back toward you for reverse. The center position is neutral.
6. Brake – when depressed, activates the transmission brake, also will disengage the Direction Control Lever if it is engaged. After brake has been engaged, the Direction control lever must be re-engaged.
7. Key Ignition – ON and start – clockwise; OFF – counterclockwise.
8. Cigarette Lighter – push in to heat.

9. Gear Selector Lever – Selects one of four gears.
10. Range Selector Lever – select high or low range.
11. PTO Control Lever – engages or disengages Power Take Off.
12. Attachment Lift Lever (810,812) – Pull toward you to raise the attachment, push away from you to lower the attachment.
13. Attachment Position Lock (810,812) – Use to lock the attachment lift in any position.
14. Hydraulic Control Lever (814,816) – Pull back to raise attachment, push forward to lower attachment, push fully forward for float (allowing attachment to follow the ground contour).
15. Choke – Move lever to “ON” position when starting a cold engine. Move lever toward “OFF” as engine warms up.
16. Light Switch – Pull to turn on lights (key must be on for lights to burn.)
17. Battery Service Door – open to check battery.

OPERATION

This tractor is equipped with a spur gear transmission and all speeds are obtained by shifting sliding spur gears. Therefore, it is necessary to stop the tractor before attempting to shift gears. The Direction Control Lever must be in Neutral and the tractor stopped before shifting the Range Selector Lever, or the Gear Selector Lever.

BEFORE STARTING:

1. Check gasoline level. Use any high quality, regular grade gasoline. The fuel tank holds 5.3 U.S. gallons.
2. Check oil level. See "Maintenance" section.
3. Check to see that PTO is in OUT position. Direction Control Lever is in Neutral (Vertical to ground) and Gear Selector Lever is in Neutral.

CAUTION: Be sure Direction Control Lever is in Neutral.

STARTING:

1. If engine is cold, move choke lever from OFF to ON position.
2. Move throttle control to approximately halfway between "IDLE" and "FAST" position.
3. Turn Ignition Key to start (Clockwise). Do not hold engaged more than 15 seconds without allowing a 30 second cooling period for starter motor.
4. As soon as the engine starts, release the key.
5. After the engine starts, and as it warms up, move choke control towards the OFF position.

STARTING TRACTOR MOVEMENT:

1. Move the Gear Selector Lever to desired gear.
2. Move Range Selector Lever to desired range.
3. To go forward, push the Direction Control Lever forward (away from you) gradually until it locks in place.
4. To back up, pull the Direction Control Lever back until it locks in place.
5. To stop tractor motion, apply brake.

NOTE: The transmission linkage is equipped with a cam so that when the brake is applied, the Direction Control Lever automatically moves to neutral.

DO NOT SLIP FORWARD-REVERSE CLUTCHES TO ACHIEVE SLOWER GROUND SPEEDS. DOWN SHIFT OR TAKE SMALLER SWATH IF GROUND SPEED IS TOO FAST FOR THE ATTACHMENT TO DO ADEQUATE JOB.

STOPPING TRACTOR:

1. Apply brake.
2. Be sure PTO Lever is in OUT position.
3. Move throttle to idle.
4. Turn ignition key counter-clockwise to shut off engine. Remove key. Tractor cannot be started without the key.

Engaging Power Take Off (P.T.O.):

1. Stop tractor motion, slow engine to fast idle. (This will reduce PTO clutch wear and prolong PTO clutch life).
2. MOVE PTO Lever from OUT to IN.

Disengaging Power Take Off (P.T.O.):

1. Move PTO Lever from IN to OUT.

CAUTION: Stop tractor and disengage PTO and turn off ignition key before attempting to work on or adjust the attachment.

Air cooled engines are designed to be operated at full throttle (3600 rpm). Operate the tractor with the engine at full throttle, particularly when operating under loads.

	Low Range (M/P/H)	
	Forward	Reverse
1	.49	1.10
2	.78	1.66
3	1.10	2.50
4	1.66	3.75

	High Range (M/P/H)	
	Forward	Reverse
1	2.50	1.10
2	3.75	1.66
3	5.60	2.50
4	8.37	3.75

REAR HITCH

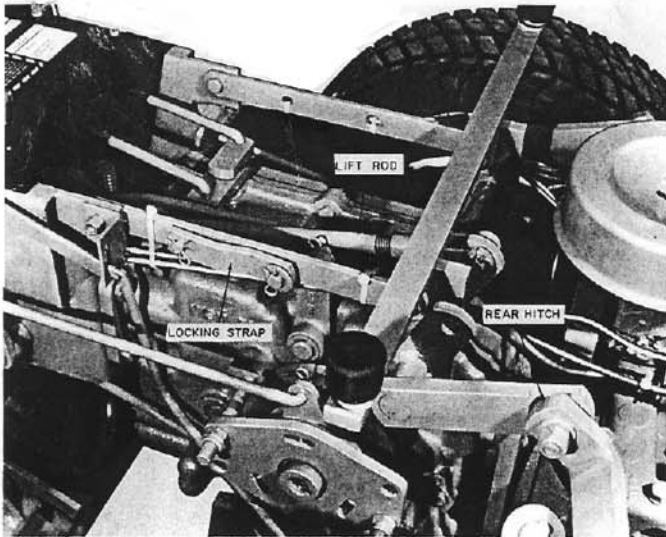

Figure 10, 816

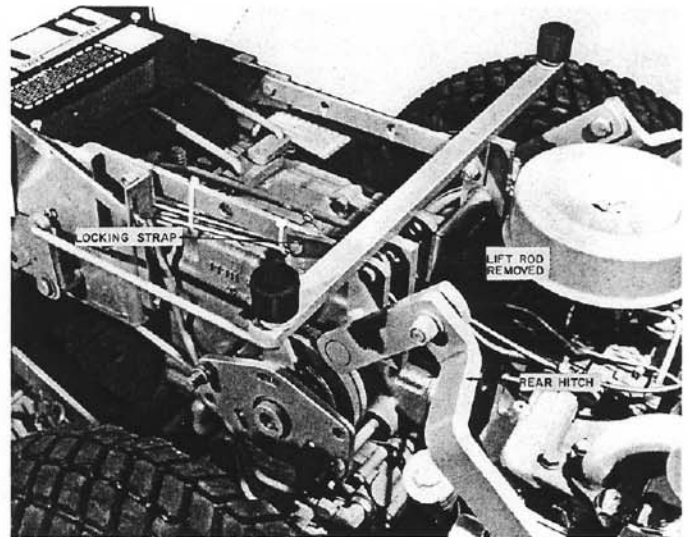

Figure 11, 816

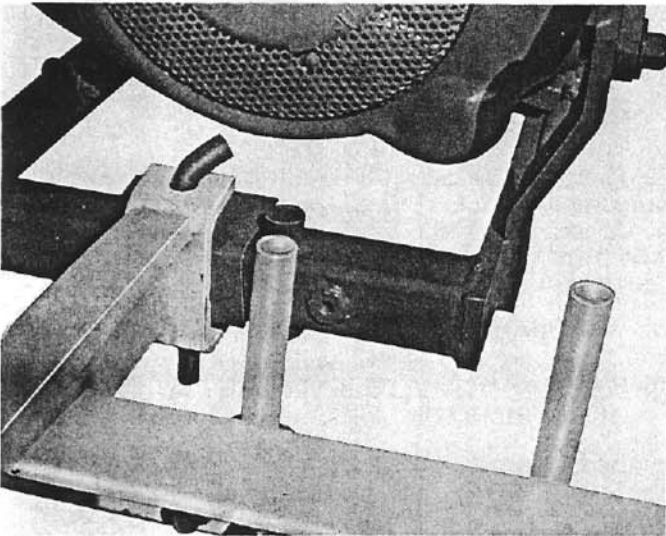

Figure 12, 816

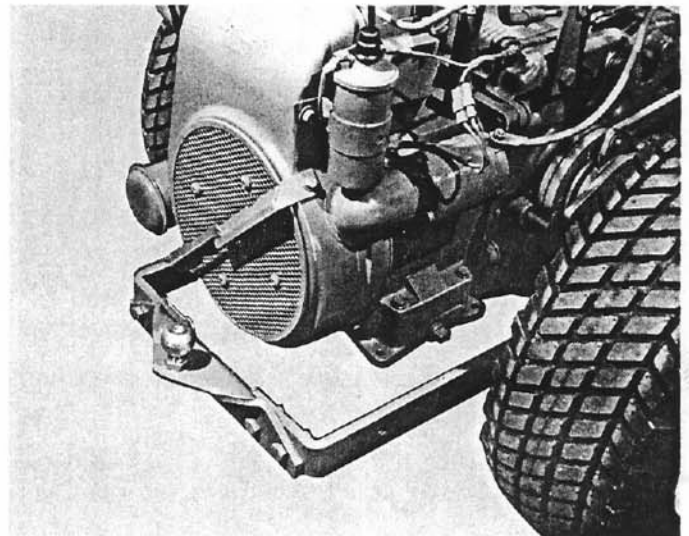

Figure 13, 810, 812, 814

816

This tractor is equipped with a liftable rear hitch for mounting of powered and non-powered rear attachments.

It also can be secured in fixed position for use of the tractor with center-mounted or front mounted attachments. This allows the raising and lowering of the attachments without affecting the position of the rear hitch.

The locking strap is secured from the frame to the rear hitch and the lift rod removed.

Figure 10 shows the hitch liftable. Figure 11 shows the hitch rigid.

Most non-powered liftable rear attachments mount with a pin. See figure 12.

Be sure to attach liftable rear attachments using the pin provided with the tractor.

Trailing attachments, such as carts, rollers, can be secured to the hitch using the trailing hitch kit See page 13.

810,812,814

This tractor is equipped with rear hitch for mounting trailing attachments using the trailing hitch kit. A liftable rear hitch is an option.

ATTACHMENTS

Center-Mount Attachments

50" Rotary Mower - 810,812,814,816

40" Rotary Mower - 810,812,814

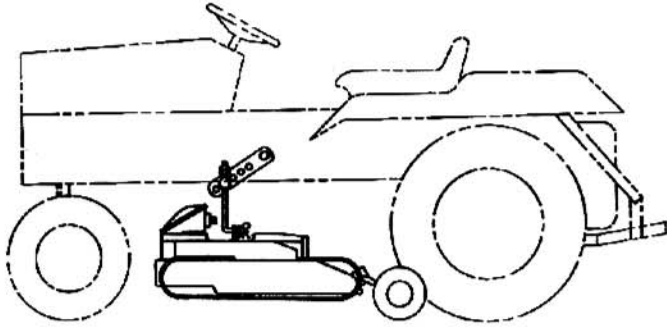

Figure 14

Mounting

Loosen the two jam nuts on the lift rod and thread them to approximately one inch from the end of the rod. Do not lock.

Turn the lift rod upside down so the pin of the mower pivot is up. Insert the mower pivot from the inside (middle of the tractor) through the second hole from the end of the lift lever shaft weldment. Rotate the lift rod so the bend is down.

Place the mower in front of tractor with the gauge wheel towards the front wheels of the tractor.

Carefully drive the tractor over the mower until the mower is approximately centered between the front and rear tires.

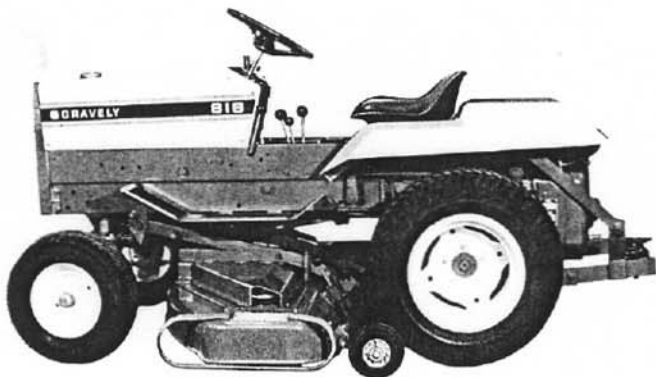

Figure 15

Insert the lift rod of the mower through the ring on the mower deck. Secure with flatwasher and hair pin cotter.

Being sure the attachment latches are open, slowly raise the mower, slipping the pivot arm weldment into the attachment latches and secure with hair pin cotters.

Raise the mower completely, be sure there is no interference between the mower deck and the bottom of the tractor. If interference is noted, lower the mower and back off the jam nuts until there is no interference when the mower is raised completely. Be sure to jam nuts together. The mower should be level when raised and clear the frame of the tractor 1/4 to 1/2 inch.

Lower mower completely and attach the drive shaft of the mower to the stub shaft of the tractor PTO.

Height Adjustment

Cutting height is controlled by the gauge wheels at the rear of the mower. Move the Height Adjustment Control in the quadrant to achieve the proper cutting height.

Lubrication

The mower has seven (7) grease fittings, these should be greased every eight (8) use hours.

Spindles (under deck) - 1 each

Belt idler arm - 1

Drive Shaft - 1

Caster Wheels - 1 each

The gear housing is filled with good grade of general purpose grease. Periodically remove the gear housing cover and check for lubrication. Commercial User - 160 hours; Homeowners - annually.

Removal

With the mower in the raised position, remove the hair pin cotters and open the attachment latches. Lower the mower fully. Remove lift rod from mower. Remove the drive shaft of the mower from the PTO shaft of the tractor.

Back tractor over mower. Remove lift rod from tractor.

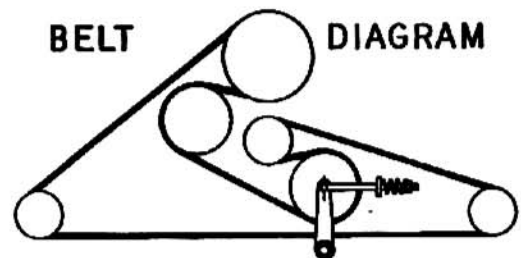

Figure 16

Belt Replacement

In case of belt replacement, refer to figure 16 for proper installation.

Front Mounted Attachments

38 - Inch Snowblower

44 - Inch Snowblower

NOTE: All directions given are with reference to the normal operator's position, i.e., as you sit on the tractor. The 19075E1 Front Drive Kit is required.

1. Remove the dust caps from each side of the center of the front axle. In one side, install a bearing, and secure in place with a retaining ring.

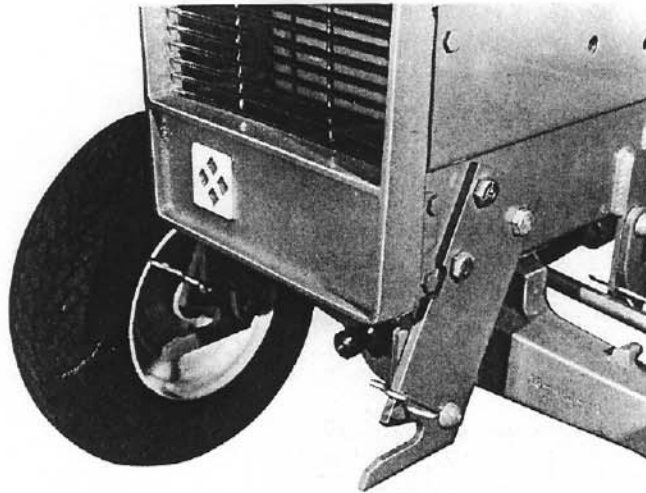

Figure 17

2. From the other side, install the shaft, long end to the rear, through the bearing. Install the other bearing, and secure in place with retaining ring. It is not necessary to remove the shaft between uses.
3. Mount the Front Attachment Bracket Assemblies on tractor. There is a Right Hand and Left Hand assembly; mount so the latches are on the inside.

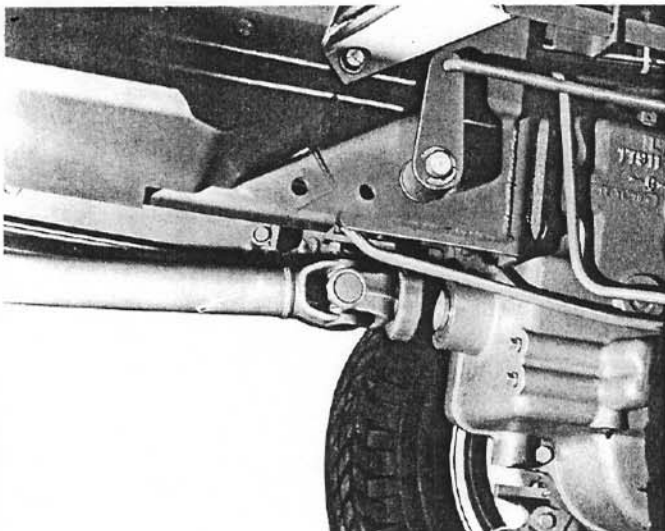

Figure 18

4. Attach the drive shaft to the PTO shaft on the transmission by pulling back on the locking collar on the universal joint and slide it on the PTO shaft. Similarly attach it to the shaft through the front axle. Be sure that the shaft locks in place.
5. Raise the rear of the snowblower to attachment bracket latch level. Hold in place with stand.

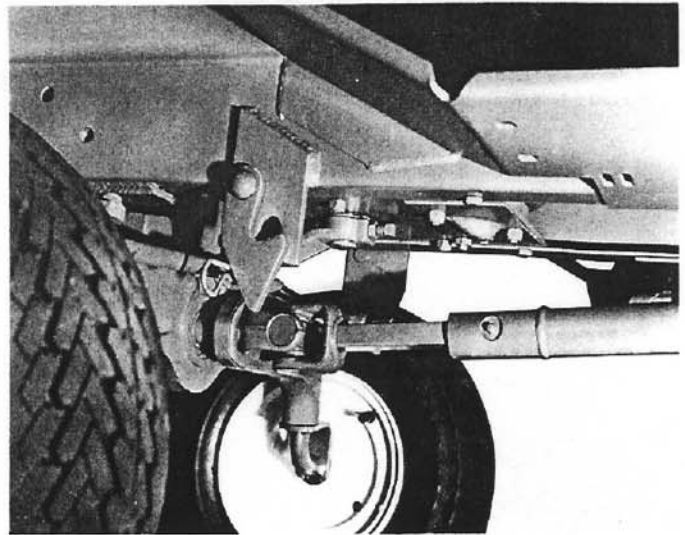

Figure 19

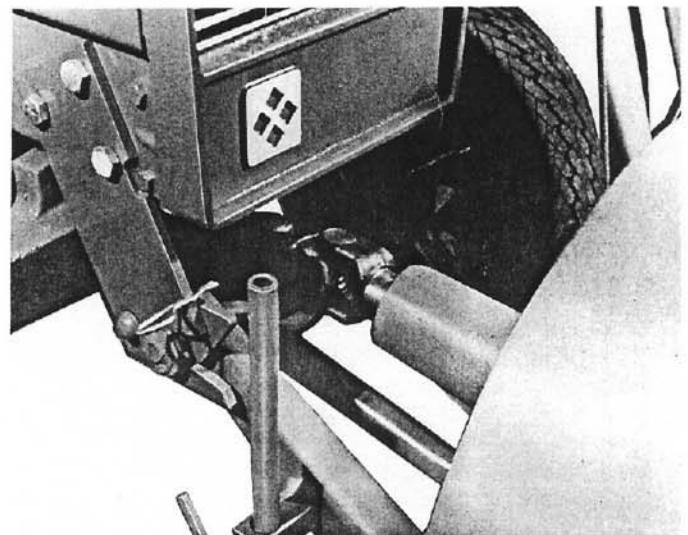

Figure 20

6. Slide the Double Joint Assembly on forward drive shaft. Position tractor approximately two inches from the snowblower.
7. Start the Double Joint Assembly on the shaft of the snowblower. Roll tractor forward until the frame on the snowblower fits in the latches on the bracket assemblies on the tractor. Close the latches and secure in place with hairpin cotter pins. Raise snowblower stand and secure in the raised position.
8. Insert the Push Rod Guide Weldment into the Push Rod and install in the top hole of the lift lever shaft weldment of the tractor. Secure with washer and hairpin cotter. Insert the push rod through the hole on the frame of the snowblower and secure with washer and hairpin cotter.

CAUTION: Use extreme care when operating Snowblower. Keep hands and feet away when auger and fan are turning. Stop engine and blower before making *any* adjustments or clearing chute of blockage.

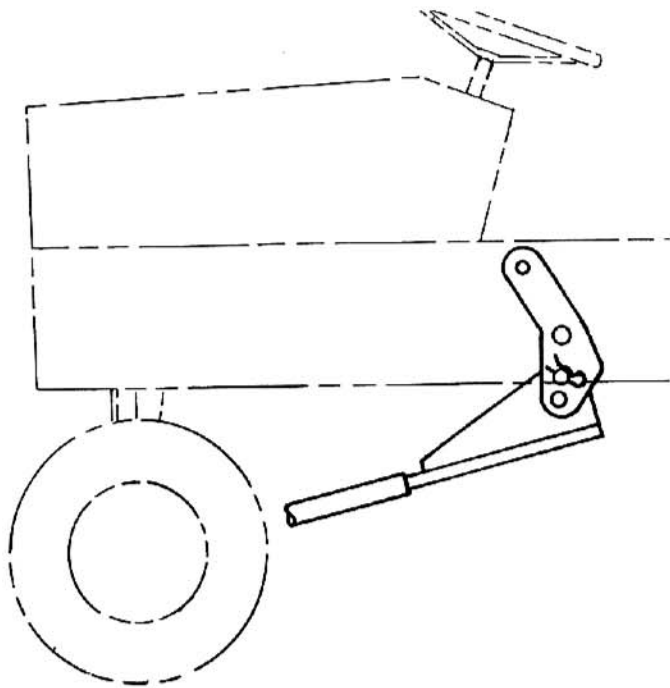

Figure 21

Removal

CAUTION: Be sure PTO is disengaged and engine stopped.

1. Lower Snowblower. Lower stand and secure. Remove hairpin cotters, raise latches and secure latches in raised position. Remove Push Rod from snowblower and Push Rod Guide Weldment from tractor.
2. Roll tractor away from snowblower. Double Joint Assembly will slide off snowblower shaft or forward drive shaft. Remove Double Joint Assembly from the snowblower shaft or the forward drive shaft. Remove the drive shaft by pulling on the locking collars on the universal joints and slide the drive shaft off the PTO shaft and the shaft through the front axle. It is not necessary to remove the Front Bracket Assemblies.

Four Bolt Mounting Attachments

Requires:

- 19075E1 – Front Drive Kit
- 11601E1 – Front Adapter Kit

1. Mount the Front Drive Kit on the tractor. (See Snowblower instructions, steps one to four).
2. Start the Double Joint Assembly on the forward drive shaft and on the adapter of the Adapter Assembly. Slide the Assembly in place in the latches, close latches and secure with hairpin cotters.

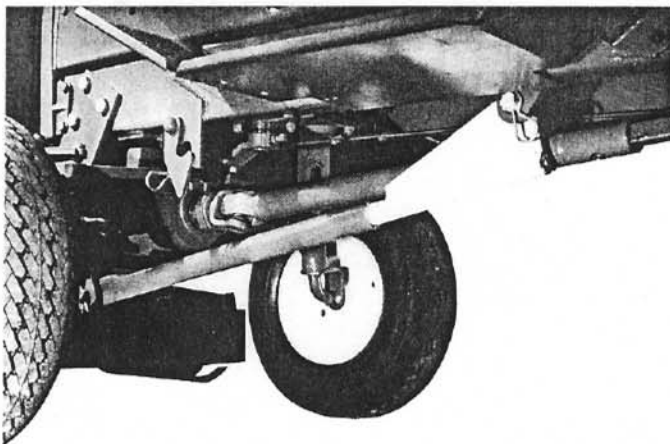

Figure 22

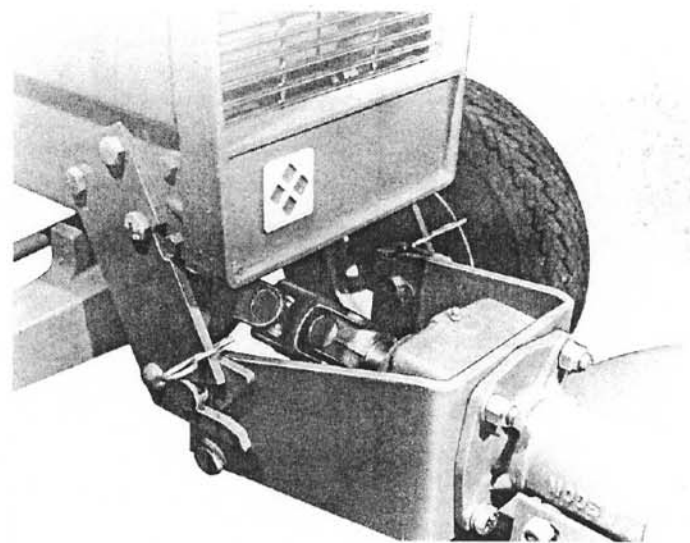

Figure 23

4. Mount attachment to the Front Adapter Kit as shown. Secure attachment in place with two bolts and two nuts.

3. Insert the Push Rod Guide Weldment into the push rod of the Front Adapter Kit. Attach the Push Rod Guide Weldment to the Lift Lever Shaft Assembly of the tractor. Attach the push rod to the Adapter Weldment.

Trailing Attachments

Require the 11627E1 Trailing Hitch Kit

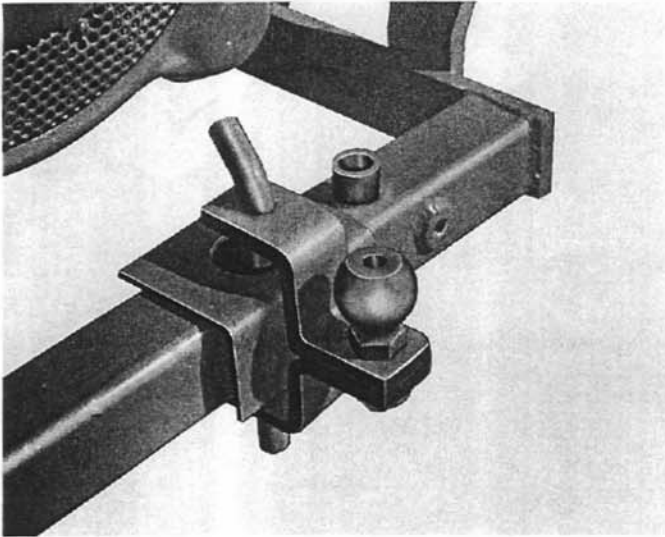

Figure 24

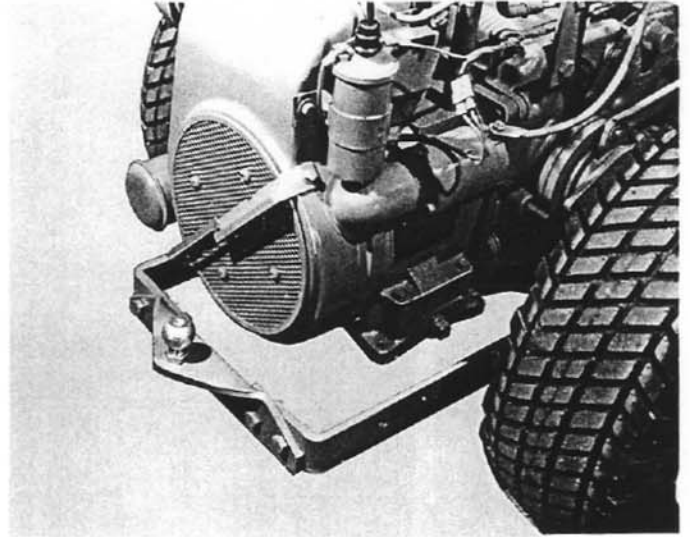

Figure 25

816

Attach the Rear Hitch to the Rear Hitch Weldment securing it in place with the hitch pin.

Thread a nut on the ball stud and insert the ball stud down through the rear hitch. Secure in place with another nut.

Stabilize the rear hitch by tightening the bolts against the pad until the pad secures the hitch in a rigid position. Jam the nuts on the bolts against the rear hitch weldment.

Attach the trailing attachment to the ball stud using the split socket.

810,812,814

Thread a nut on the ball stud and insert the ball stud down through the rear hitch. Secure in place with another nut.

Attach the trailing attachment to the ball stud using the split socket.

Rear Mount Attachments

18886E1 Rotary Tiller

Requires:

816 – Rear PTO

810,812,814 – Rear PTO
optional Rear Hitch

Recommended:

11924E1 Front Wheel Weights

11925E1 Rear Wheel Weights

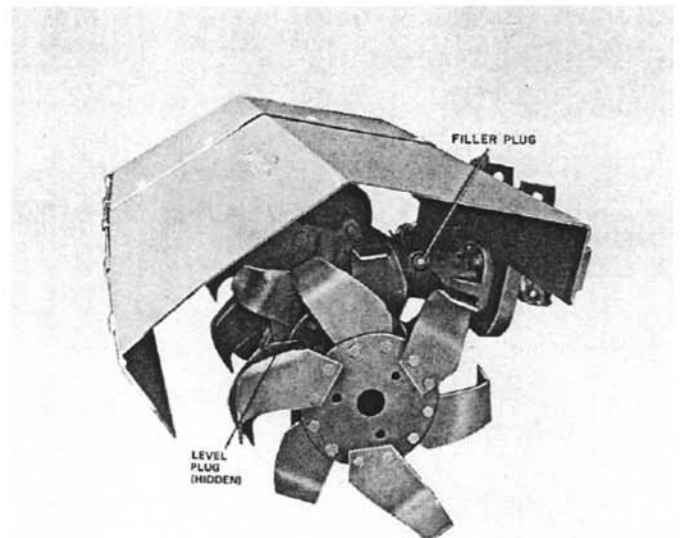

Figure 26

Lubrication-Tiller:

Use general purpose grease to lubricate the shaft in the axle bearing retainer. Use light oil on the quick disconnect of the chain drive assembly before using. Clean and lubricate after each use. Use SAE 30 oil in the chain drive assembly. Fill to the bottom plug level holding the chain drive assembly vertically (quick disconnect to top and output shaft on bottom). Check level periodically.

Lubrication-Rear PTO:

Use general purpose grease in Universal joint. Use light oil on quick disconnect of Universal joint and clean and lubricate after each usage. Use SAE 90 gear lubricant in gear box. Fill gear box to check plug (plug on side of gear box) with tiller level. Oil level should be checked periodically.

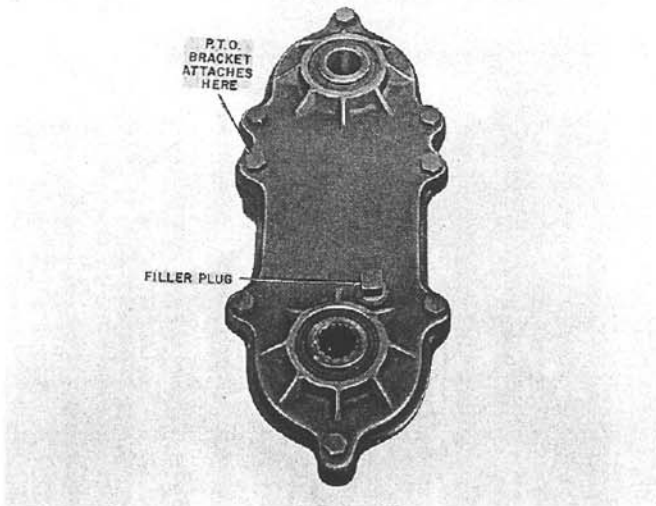

Figure 27

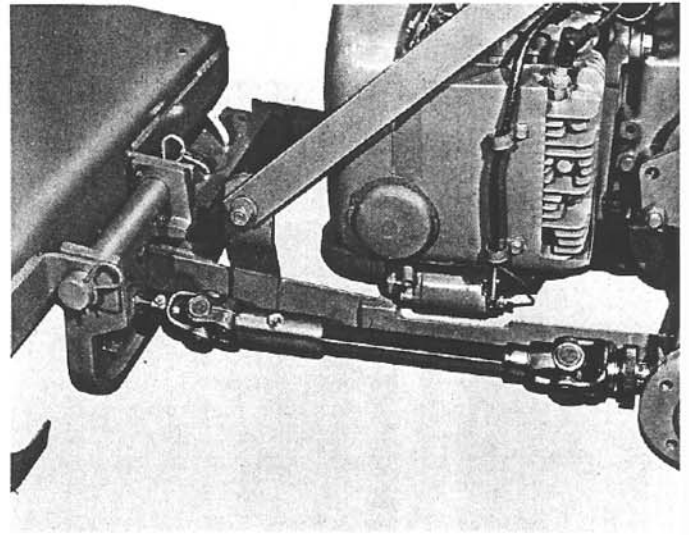

Figure 29

Mounting:

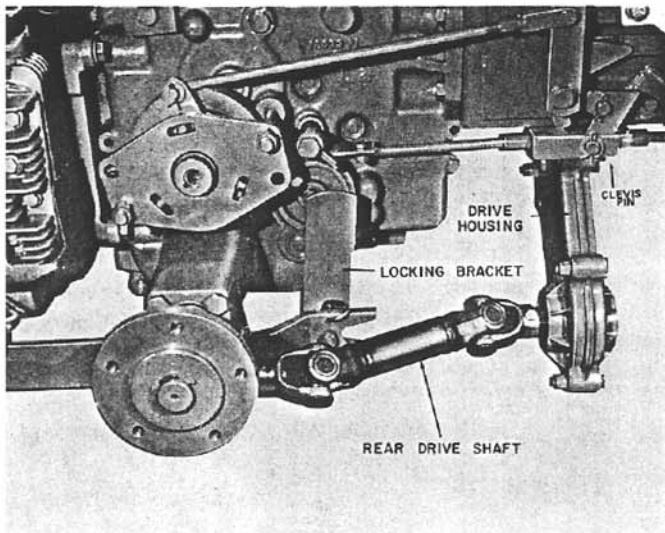

Figure 28

Be sure the Rear PTO and hitch are installed on the tractor.

Mount the tiller on the rear hitch using the 2 holes next to the tiller gear box. Secure in place with the two pins provided.

Connect the driveshaft of the tiller to the driveshaft from the rear PTO.

Operation:

The attachment lift system of the tractor controls the depth of tilling.

Operation of the tiller with the engine at full throttle is recommended because maximum power is thus provided.

Engage the direction control lever and then lower the tiller. Do not DROP tiller into ground.

Operation at slow ground speeds gives a finer soil condition (smaller soil particles).

Select that gear which will produce the desired condition, usually 1st gear, low range, however experimentation may indicate use of a slightly higher gear is acceptable.

Overlap cuts slightly to avoid leaving ridges of untilled soil.

SAFETY FIRST:

Clear area to be tilled of all trash such as rocks, large stones, wire, bones, etc.

Know the controls and how to stop tractor and tiller quickly.

Keep bystanders away.

Disengage all clutches before starting engine.

Disengage all power and turn off engine before parking, making adjustments, or clearing trash (wire, vines, etc.) from tiller tines.

Use caution when maneuvering or transporting.

Keep tine cover and shield in place.

Stop and inspect tiller for damage after striking large objects such as buried stumps or rocks.

Axle Mount Attachments

48" Snowdozer

Front-Mount 50" Rotary Mower

Front-Mount 40" Rotary Mower

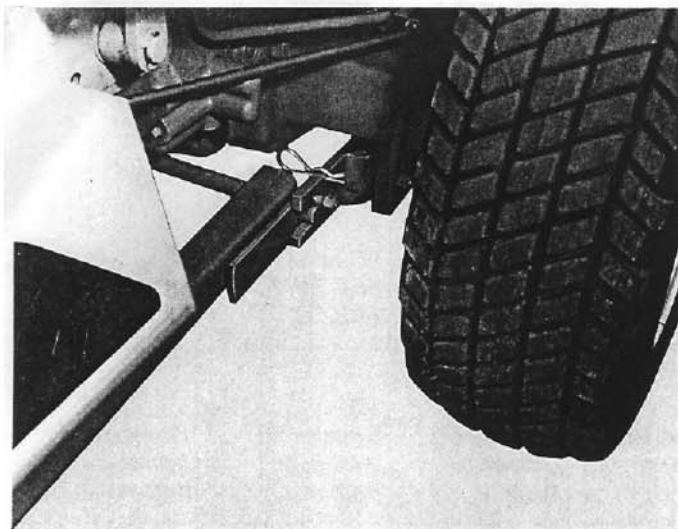

Figure 30

1. Move tractor over frame of attachments. On Snowdozer, remove pins and lay blade angle control down to prevent tire from running over it.
2. Place the mounting points of the attachment in the notches in the rear hitch weldment. Close latches and secure in place with hairpin coppers.
3. Mowers — Install the lift pivot in the last hole (closest cross shaft) of the lift lever shaft weldment.
Snowdozer — Install the lift pivot in the next to the last hole of the lever shaft weldment.

NOTE: The blade has a lift-lower range of about 10 inches. The blade can be lowered more than the normal two and one-half inches below ground level by setting the lift pivot assembly in one of the three holes below the normal position. However, this decreases the ground clearance in the raised position.

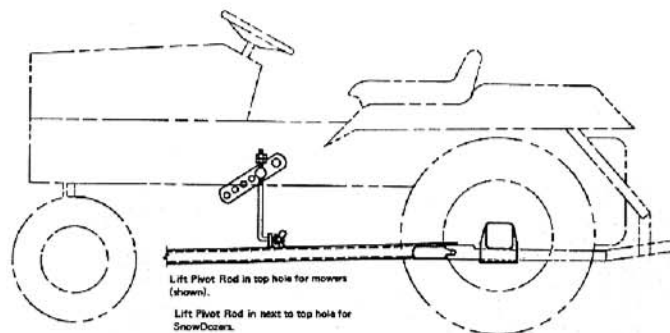

Figure 31

Mowers Only

4. Install the driveshaft of the Front Drive Kit from the PTO to the shaft through the front axle. Attach the mower driveshaft to the shaft through the front axle.

Cutting Height Adjustment

Cutting height is adjusted with the two level adjustment rods and the adjustment pin. The mower should be level both front to rear and side to side.

Lubrication

Grease with general purpose. Grease all fittings at least every 8 operating hours.

Blade Spindles — 1 each

Drive Shaft — 1

Idler Pivot Arm — 1

Wheel Arm — 1 each

Guage Wheel — 1 each

Periodically, check the grease level of the gearbox. Capacity is one pound of general purpose grease.

SPECIFICATIONS

MODEL	810 (19489E1)	812 (19490E1)	812 (19726E1)	814 (19752E1)	814 (18800E1)	816 (18803E1)
ENGINE Type Horsepower @ 3600 rpm Number of Cylinder Stroke (inches) Bore (inches) Displacement (cu. in.) Oil Sump Capacity (US pints) Oil Specifications Winter Summer	4 cycle air cooled 10 1 2.87 3.20 23.90 5 SC or SD SAE 5W20 SAE 30	4 cycle air cooled 12 1 3.25 3.37 29.07 5 SC or SD SAE 5W20 SAE 30	4 cycle air cooled 12 1 3.25 3.37 29.07 5 SC or SD SAE 5W20 SAE 30	4 cycle air cooled 14 1 3.25 3.50 31.27 5 SC or SD SAE 5W20 SAE 30	4 cycle air cooled 14 1 3.25 3.50 31.27 5 SC or SD SAE 5W20 SAE 30	4 cycle air cooled 16.5 2 3.00 3.25 49.80 4 SC or SD SAE 5W20 SAE 30
FUEL SYSTEM Capacity (US gal.) Grade	5.3 Regular-90 octane or higher	5.3 Regular-90 octane or higher	5.3 Regular-90 octane or higher	5.3 Regular-90 octane or higher	5.3 Regular-90 octane or higher	5.3 Regular-90 octane or higher
TRANSMISSION Oil Capacity (US qts.) Oil Recommendations	6 SAE 30	6 SAE 30	6 SAE 30	6 SAE 30	6 SAE 30	6 SAE 30
HYDRAULIC SYSTEM Fluid Type Capacity	DNA	DNA	Type A Suffix A Auto-Trans. Fluid 1½ US qts.	DNA	Type A Suffix A Auto-Trans. Fluid 1½ US qts.	Type A Suffix A Auto-Trans. Fluid 1½ US qts.

Warranty

Products manufactured by Gravely are warranted to be free from defective material and workmanship for a period of one year from date of purchase, under normal use by a homeowner, and for a period of ninety (90) days from date of purchase, when used for commercial purposes.

Any defective part manufactured by Gravely will be replaced without charge provided such part is certified as defective by the manufacturer or by the manufacturer's expressly authorized representative.

IMPORTANT PROVISIONS

This warranty is not subject to change or modification by field representatives or Gravely dealers. Any warranty other than the warranty expressly stated above will not be binding upon the manufacturer.

Certain components carry separate warranties by the manufacturer of such components. Defective components are subject to their manufacturer's warranties, and any claims, work, or return of parts must be through an authorized Gravely dealer. Service costs for the transporting of a unit to and from the dealer are the responsibilities of the customer, and when such service is performed by the dealer, the dealer will charge the customer the usual rate for such service.

It is the customer's responsibility to mail the "Warranty Card" to the manufacturer within fourteen (14) days after date of purchase to ensure prompt handling of any warranty claim by the dealer or the manufacturer.



ONE GRAVELLY LANE
Clemmons, North Carolina 27012

