



# 800/8000 SERIES SERVICE MANUAL

## ▲ SAFETY MESSAGE ▲

The product for which you have requested information or replacement parts is not a current product. The replacement models incorporate product designs, safety features, safety instructions or warnings which represent the latest "State Of The Art" developments. For your safety and those around you please contact your nearest Ariens/Gravely Dealer for a demonstration of the current product safety provisions and features.

## INTRODUCTION

This manual contains service instructions on the Kohler K241 and K301 engines only.

The Gravely factory does not service the 16 hp Briggs & Stratton engine.

These engines are covered under the engine manufacturers warranty. Service and parts manuals may be obtained from the engine manufacturer.

TO CONTINUE ITS PROGRAM OF QUALITY AND DESIGN IMPROVEMENT, THE MANUFACTURER RESERVES THE RIGHT TO CHANGE SPECIFICATIONS, AND DESIGNS WITHOUT NOTICE AND WITHOUT INCURRING OBLIGATIONS.



1 Gravely Lane  
Clemmons, N.C. 27012

## TABLE OF CONTENTS

Routine Maintenance .....	4
Front Axle and Steering .....	7
Controls .....	8
Hydraulic System .....	9
Fuel System .....	10
Governor System .....	13
Battery Ignition System .....	14
Electrical Starting — Charging Systems .....	17
Starter Motors .....	19
Engine	
General Service .....	22
Inspection — Disassembly .....	23
Reconditioning .....	25
Reassembly .....	29
Specifications .....	36
Fits and Clearances .....	37
Transmission .....	38
Tractor Specifications .....	Inside Back Cover

## SAFETY SPECIFICATIONS

1. Know the controls and how to stop quickly — READ THE OWNER'S MANUAL
2. Do not allow children to operate vehicle. Do not allow adults to operate it without proper instructions.
3. Do not carry passengers. Keep children and pets a safe distance away.
4. Clear work area of objects which might be picked up and thrown.
5. Disengage all attachment clutches and shift into neutral before attempting to start engine.
6. Disengage power to attachments, set park brake and stop engine before leaving operator position.
7. Disengage power to attachments, set park brake and stop engine before making any repairs or adjustments.
8. Disengage power to attachments when transporting or not in use.
9. Take all possible precautions when leaving vehicle unattended; such as disengaging power take-off, lowering attachments, shifting into neutral, setting parking brake, stopping engine and removing key.
10. Do not stop or start suddenly when going uphill or downhill. Mow up and down the face of steep slopes; never across the face.
11. Reduce speed on slopes and in sharp turns to prevent tipping or loss of control. Exercise extreme caution when changing direction on slopes.
12. Stay alert for holes in terrain and other hidden hazards.
13. Use care when pulling loads or using heavy equipment.
  - A. Use only approved drawbar hitch points.
  - B. Limit loads to those you can safely control.
  - C. Do not turn sharply. Use care when backing.
  - D. Use wheel weights when suggested in owner's manual.
14. Watch out for traffic when crossing or near roadways.
15. When using any attachment, never direct discharge of material toward bystanders nor allow anyone near vehicle while in operation.
16. Handle gasoline with care — it is highly flammable.
  - A. Use approved gasoline container.
  - B. Never remove cap or add gasoline to a running or hot engine or fill fuel tank indoors. Wipe up spilled gasoline.
  - C. Open doors if engine is run in garage — exhaust fumes are dangerous. Do not run engine indoors.
17. Keep vehicle and attachments in good operating condition and keep safety devices in place.
18. Keep all nuts, bolts and screws tight to be sure equipment is in safe working condition.
19. Never store equipment with gasoline in the tank inside of building where fumes may reach an open flame or spark.
20. Allow engine to cool before storing in any enclosure.
21. To reduce fire hazard keep engine free of grass, leaves or excessive grease.
22. Vehicle and attachments should be stopped and inspected for damage after striking a foreign object and the damage should be repaired before operating the equipment.
23. Do not change engine governor setting or overspeed engine.
24. When using vehicle with mower;
  - A. Mow only in daylight or in good artificial light.
  - B. Never make a cutting height adjustment while engine is running. If operator must dismount to do so.
  - C. Shut engine off when unclogging chute.
  - D. Check blade bolts for proper tightness at frequent intervals.

# ROUTINE MAINTENANCE

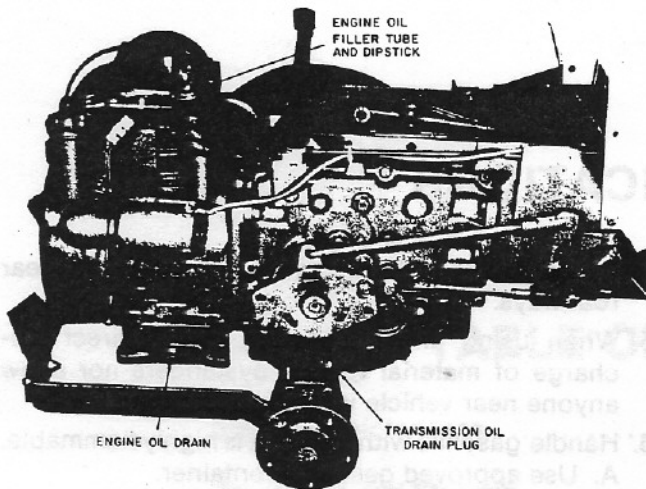

Figure 2

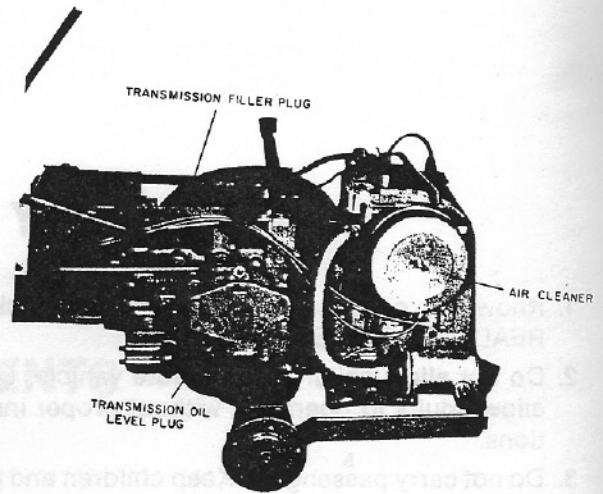

Figure 3

## TRANSMISSION

Capacity: 6 U.S. Quarts (5.7 Liters)

Use SAE 10W-30 API classification SC or SD oil for year around use.

Change transmission oil after first 25 hours of operation. The change should be made when the oil is warm and particles are in suspension. Regular draining of the oil in the transmission is not necessary. Check transmission oil level while performing routine maintenance. Add oil if necessary through the fill tube, but never over fill.

The drain plug is on the right side of the transmission near the bottom of the transmission case.

The transmission oil fill tube is equipped with a vented cap. No other type should be used. The vent hole should be checked when performing routine maintenance and cleared of any obstruction.

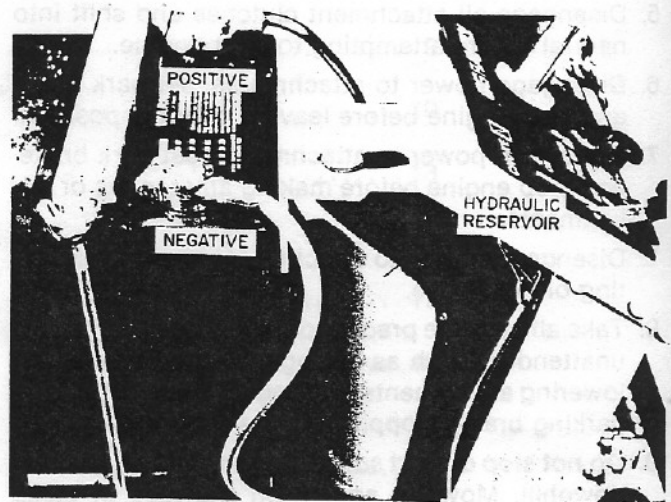

Figure 4

## ENGINE

### Capacity

10 hp, 12 hp Kohler, 16 hp B&S.....	4 U.S. Pints (1.9 Liters)
16.5 hp Onan .....	7 U.S. Pints (3.3 Liters)
Grade .....	API Service SC
Viscosity .....	Above 0 F 10W-30 (-18C) Below 0 F 5W-20 (-18 C)

Check oil level daily. Maintain at full mark. Do not overfill. Change oil after first 5 hours and then every 25 hours or oftener under dusty conditions. Drain plug is on the right side of the engine base.

### Attachment Lift (Hydraulic Lift Models)

**Do not run tractor without fluid in the hydraulic system.**

Capacity — 1½ U. S. Quarts. (1.4 Liters)

Use only Type A Suffix A Automatic transmission Fluid such as Shell Donax T-6 or Gulf Dexron Automatic Transmission fluid.

Check fluid level every oil change. Use care when checking fluid level. Do not allow dirt to enter the hydraulic system.

Maintain level at full mark on dipstick.

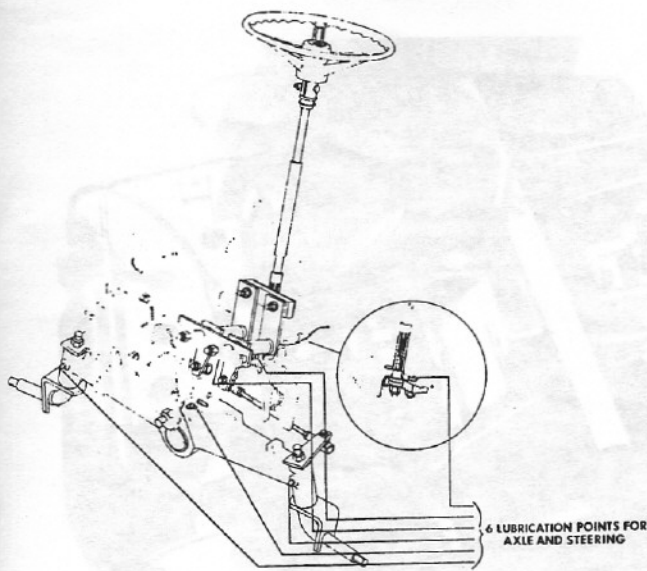

Figure 5

## GREASING

There are 7 grease fittings on the tractor. Grease with general purpose grease every eight hours.

- King Pin Weldments — 2
- Axle Pivot Pin — 1
- Direction Control Lever — 1
- Steering Assembly — 3

### Procedure

1. Raise front of chassis. Support frame with jack-stands, allowing front axle to hang free, relieving pressure on the bottom bearing points. This allows better grease penetration.
2. Clean grease fittings of all debris.
3. Add grease until it comes out around bearings.
4. Lower chassis and remove excess grease.

While performing chassis lubrication, apply a small amount of grease to the rack and pinion mechanism.

Any time the tractor is washed or "hosed off", it should be greased to force any moisture out of the bearings.

If the tractor is operated with the tractor wheels in water above the front wheel bearing, the front wheel bearings should be repacked immediately with wheel bearing grease.

Periodic light oiling of pivot points of linkage aids operation.

### Air Cleaner

Clean or replace when necessary. A loss of power is an indication that air cleaner service is required.

**Do not clean the element with compressed air or wash the element.**

The air cleaner element should be cleaned by gentle tapping on a flat surface.

Replace the element if it is bent, crushed or damaged in any way, or if the dirt does not fall readily.

When reinstalling, be sure the element fits the adapter plate and the wing nut is finger tight.

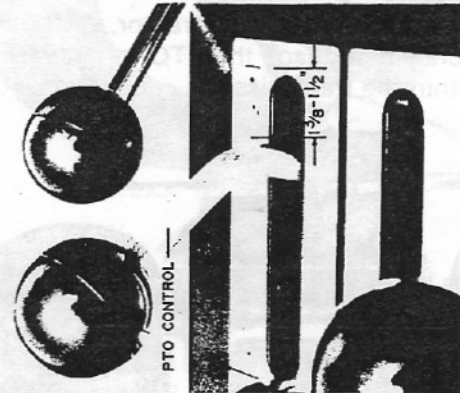

Figure 6

## TIRES

Tire pressure is 12-18 psi. (0.84 — 1.26 kpc). Check regularly and maintain at proper pressure.

## BATTERY

Regularly check electrolyte level. Maintain at proper level by adding distilled water. When charging the battery, be sure the key is in the "OFF" position.

## CLEARANCES (KOHLER ENGINE)

Spark Plug gap	.025" (0.63mm)
Intake valve	.008-.010" (.20 — .25 mm)
Exhaust valve	.017 — .020" (.43 — .50 mm)

## FORWARD/REVERSE CLUTCHES

Adjust to .040" (1.0mm) when gap exceeds .060" (1.5mm)

Adjust by tightening nuts on studs. **Be sure nuts are tightened equally.**

Minimum lining thickness .020" — (.50mm)

Every 24 hours of operation, lubricate the clutch cam bearing, exposed end of splined clutch shaft, cam rollers and all pivot points of clutch linkage with regular grade oil. This will assist in smoother forward clutch operation and minimize grabbing. Maintain correct clutch adjustment as described.

## PTO CLUTCH

It is necessary that the PTO lever have free travel. If the free travel is too great, the clutch will not disengage and if the free travel is too little, the clutch will activate too hard and operation will be affected. With the PTO lever engaged (IN POSITION) there would be a  $1\frac{3}{8}$ " (3.5cm) to  $1\frac{1}{2}$ " (3.8 cm) of free travel between the lever and the back of the slot in the cover plate.

When the free travel reaches 1" (2.54 cm), adjust the clevis on the PTO rod until there is  $1\frac{3}{8}$ " (3.5cm) to  $1\frac{1}{2}$ " (3.8cm) of free travel of the lever again.

NOTE: When operating the tractor, without a powered attachment, engage the PTO to increase oil circulation within the transmission.

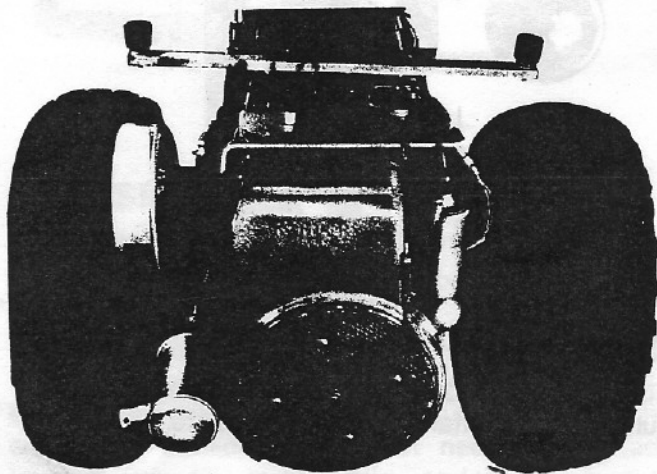

Figure 7

## ENGINE

### Engine Removal

1. Shut off fuel at tank.
2. Drain oil from transmission.
3. Remove ground cable (—) from battery.
4. Remove the choke and throttle controls from linkage at engine.
5. Separate fuel line at connection.
6. Remove wire from starter motor.
7. Separate wiring harness at connector.
8. Remove rear hitch from tractor.
9. Remove 2 bottom bolts securing the engine and engine adaptor to the transmission case.
10. Next remove the 2 top bolts securing the engine and engine adaptor to the transmission case.
11. Using a floor jack under the engine oil pan, carefully roll the engine straight back and away from the transmission.

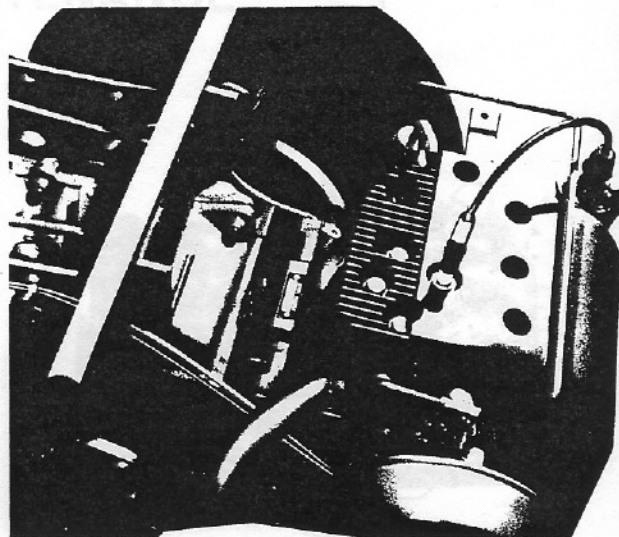

Figure 8

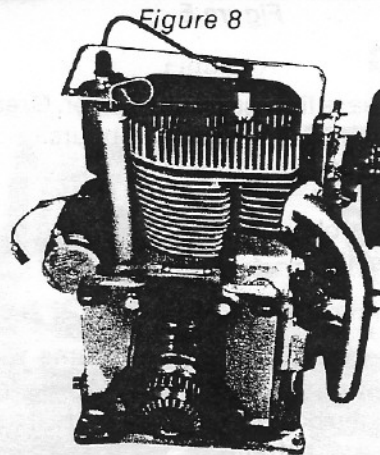

Figure 9

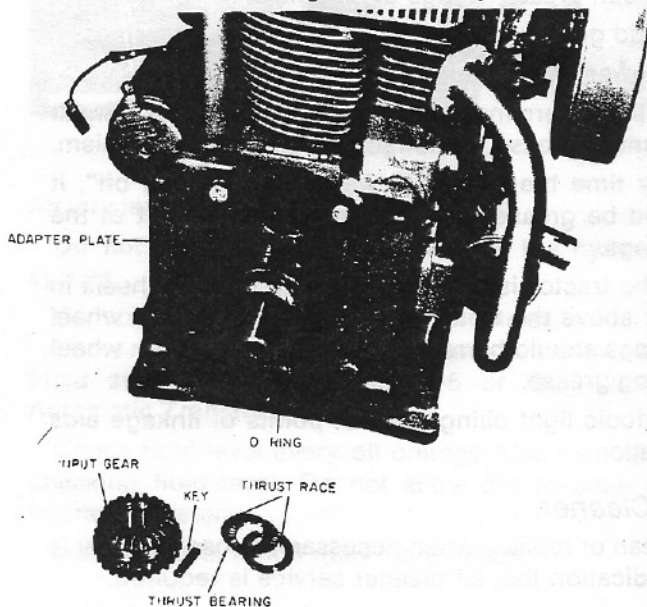

Figure 10

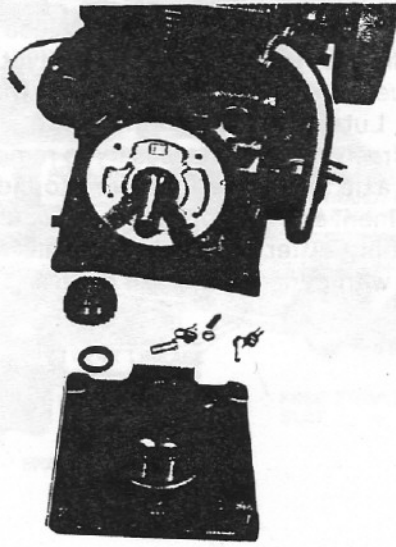

Figure 11

### Engine Adapter and Input Gear

The transmission input gear is secured to the crankshaft extension with a key. A thrust bearing between 2 thrust races is located between the input gear and the adapter.

To remove the adapter, remove the input gear, thrust bearing and races.

Remove the 3 bolts and socket head screw securing the adapter plate to the engine block.

The O-rings and gasket should be replaced prior to reinstallation.

### Engine Installation

1. Support the engine on a floor jack, raise it to the proper level.

2. Slide the engine straight into the back of the transmission. It may be necessary to turn the PTO shaft at the front of the transmission by hand to get the gear teeth lined up so that the input gear will slide in.

3. Secure in place with the two upper bolts.

4. Install the two lower bolts.

5. Connect wiring harness at connector.

6. Connect cable to starter motor.

7. Connect fuel line.

8. Connect choke and throttle controls to linkage at Engine.

9. Install rear hitch.

10. Add oil transmission to full level. Capacity is 6 U.S. quarts (5.7 Liters) 10W-30.

11. Install ground cable on battery.

12. Turn on fuel tank.



Figure 12

### Front Wheel

The front wheels are supported by tapered roller bearings. Therefore, the bearings are adjustable.

Overtightening or undertightening will lead to premature bearing failure.

The bearings should be packed upon assembly and repacked every season or oftener under commercial use.

If the tractor is operated with the bearings under water, the bearings should be repacked immediately.

Adjust the bearing, by removing the dust cap using Snap-On GCP-10 grease cap tool or similar tool. Tighten the locknut until the bearings drag, then back nut off until there is no drag but still no backlash. Reinstall the dust cap. Do not pound on the cap, use a small punch on the rim around the edge.

Maintain tire pressure at 12-18 psi. (0.84 — 1.26 kpc)

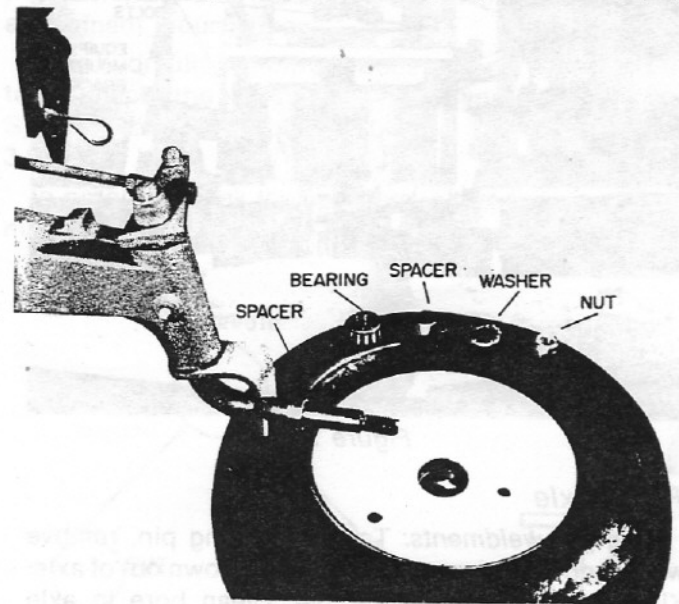

Figure 13



## TOE-IN

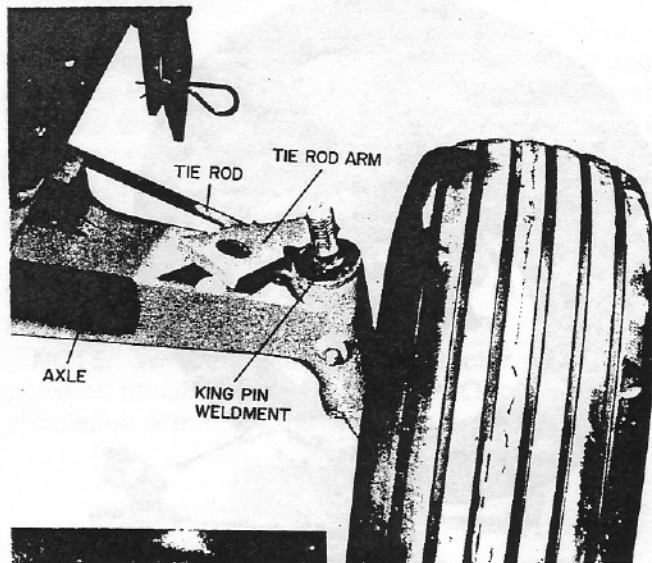

Figure 14

A toe-in of 0- $\frac{3}{4}$ " (1.9 cm) is acceptable. To measure, be sure the pinion is located in the center of the rack. Measure the distance from center of tire to center of tire on the back of the front tires and then measure on the front. The front measurement should be 0- $\frac{3}{4}$ " (1.9 cm) less than the back measurement.

**Adjustment:** Check to see which wheel looks excessively toed-in or toed-out. Remove the nut and tie rod arm from the king pin of that wheel. Turn wheel, reinstall tie rod arm. Recheck measurements. Repeat if necessary. Reinstall nut.

Do not turn steering wheel while tie rod arm is loose.

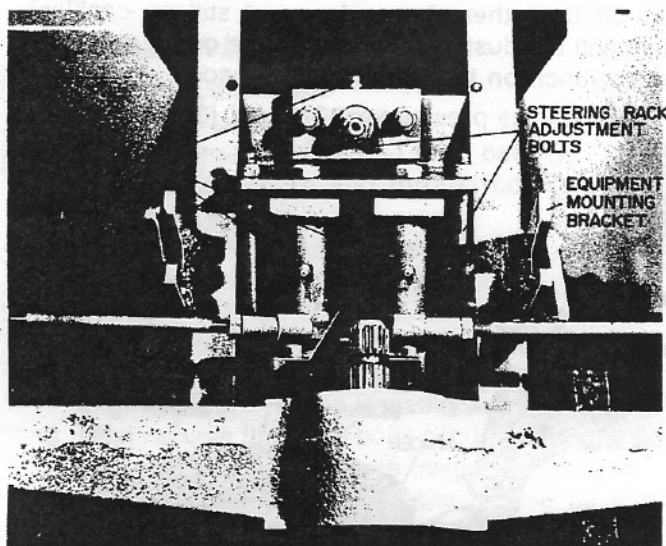

Figure 15

## Front Axle

**King pin weldments:** To remove king pin, remove wheel and tie rod arm, slide king pin down out of axle. King pins are interchangeable. Clean bore in axle before installing new king pin. Lightly grease new king pin before installation. Grease liberally through fitting after assembly. Be sure to check toe-in of front wheels.

**Steering Axle:** The axle is held in place by the axle pivot weldment. If an axle does not pivot freely, it is usually due to a lack of lubrication of the axle pivot weldment. Lubricate through the fitting, if it still does not move freely it will be necessary to remove the axle. When the axle is removed, be sure to clean the axle pivot weldment and the bore in the axle. Lubricate prior to reassembly. After assembly lubricate well through the fitting with general purpose grease.

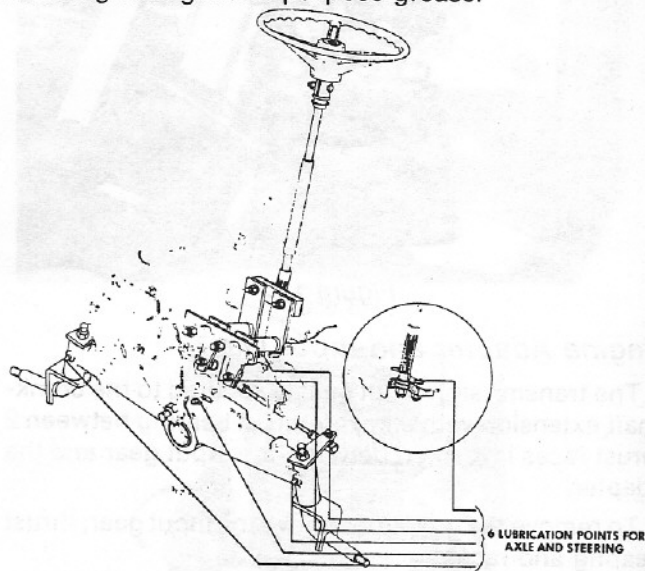

Figure 16

## STEERING ASSEMBLY ADJUSTMENTS:

In the event the steering becomes loose, adjustments can be made in the rack and pinion as follows:

1. Turn wheels all the way to the right.
2. Tighten the adjusting nut on the left.
3. Turn wheels all the way to the left.
4. Tighten the adjusting nut on the right.

Do not over tighten the adjusting bolts. Bolts need to be tight enough not to allow up or down movement. Bolts should be able to be moved sideways.

**NOTE:** Tractor hood must be on and secure when making steering adjustments.

## CONTROLS

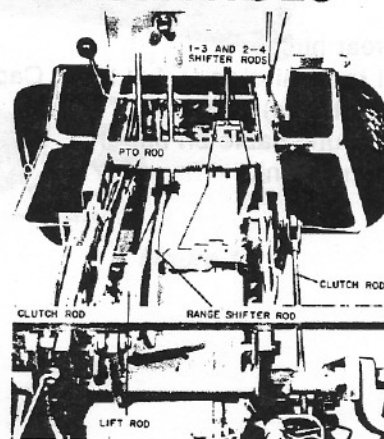

Figure 17

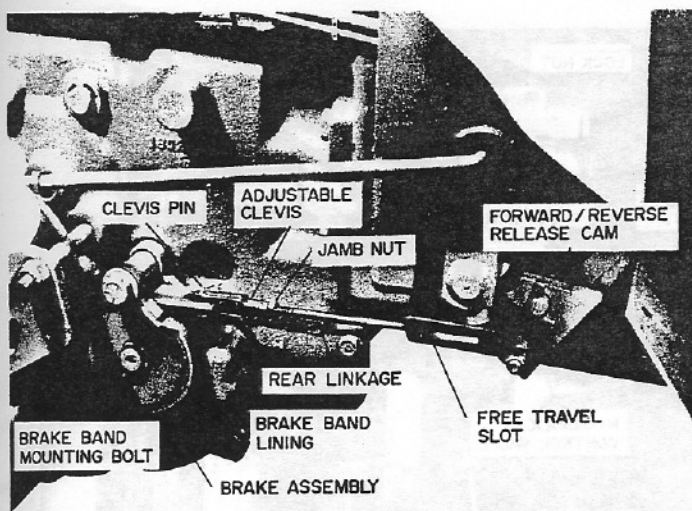

Figure 18

### Forward-Reverse

The clutch rods are equipped with adjustable yokes. To adjust the forward-reverse lever:

1. Move the forward-reverse lever to neutral.
2. Disconnect the rod from the clutch assembly on each side of the transmission.
3. Adjust the clutch until gap is .040"-.060" (1.0 to 1.5 mm) and is even all around.
4. Be sure the direction control lever is vertical.
5. Connect the clutch rods to clutch cams on each side. Adjust the clutch rods if necessary. The clutch cams are spring-loaded and are in their neutral position. Do not move the clutch cam arm to connect it to the clutch rod.

### 1-3 and 2-4 Linkage

To obtain proper shifting between gears, the linkage must be in proper adjustment.

The shifter arms on the transmission must be straight across as well as the slots of the shifter arm weldments. Adjust the clutch rods in the clevis to obtain the proper adjustment.

### Brake

The brake cam acts to disengage the direction control lever when the brake is engaged.

The brake cam contacts the tabs on the clutch cross shaft weldment, moving the clutches to neutral.

## BRAKE, SERVICE AND PARKING

Maintain proper adjustment for safe operation. Adjust as necessary. Replace brake band when thinnest part of lining is less than .020" (0.5mm) or appears to be very thin.

Replace brake lining by removing the clevis and mounting bolt. Brake lining band can then be removed. When new lining has been installed readjust brake as explained in ADJUSTMENT PROCEDURE.

### Correct Adjustment

When direction control is fully engaged (locked) in either forward or reverse and brake pedal is moved

forward, braking should not start until direction control automatically returns to neutral. Timing is accomplished by brake linkage and is essential for safe operation.

### Adjustment Procedure

1. Park tractor on level ground, and block wheels.
2. Put direction control in forward position.
3. Slowly depress brake pedal until control lever returns to neutral. Engage stop rod as explained in OPERATION section.
4. Observe free travel of brake linkage rod in slot. (Braking action should start at this point).
5. Remove clevis pin, loosen jam nut and turn clevis until the free movement is taken up in slot. Reconnect clevis and tighten jam nut.
6. Repeat steps 2, 3 and 4. Braking action should not start until direction control is returned to neutral.

NOTE: Optional individual rear wheel brakes are available for 800 Series tractors. Contact your Gravelly Dealer for more information.

## HYDRAULIC SYSTEM

Hydraulic systems are fairly trouble-free. Do not open the system unless you are sure there is a hydraulic system problem.

Check first:

1. Hydraulic fluid level. Maintain level according to dipstick. Use care to be sure no foreign material enters the reservoir.
2. Engine speed is at 3600 r.p.m.
3. Debris build up is not restricting movement of linkage.
4. Load exceeds capacity of hydraulic system. Do not attempt to lift other than attachments mounted at attachment mount areas.

If the hydraulic system still does not operate satisfactory, check the pressure of the hydraulic system. System pressure should be 1000 psi  $\pm$  50 (70.3 kpc  $^2 \pm$  3.52).

In order to check the pressure, a test fitting can be made from the hydraulic pump "out" port fitting.

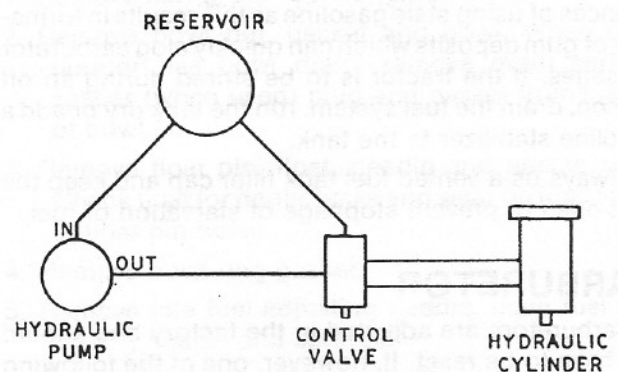

Figure 19

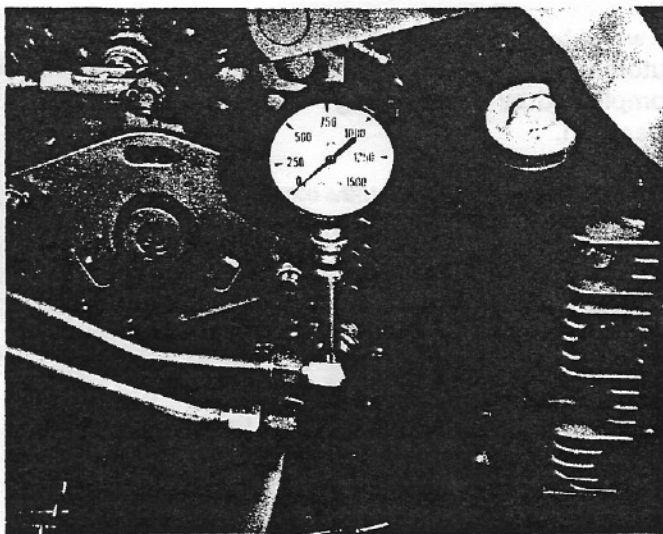

Figure 20

Drill the side of the fitting and thread for 1/4" (6.35mm) pipe.

To check a hydraulic system, remove the fitting from the "out" port of hydraulic pump. Install the special fitting and gauge, connect line. Recheck hydraulic fluid level.

Start tractor, and check the hydraulic system for leaks. Accelerate tractor to full throttle, Operate the hydraulic system. Pressure should read 1000 psi  $\pm$  50 (70.3 kpc  $\pm$  3.52) when the piston of the cylinder reaches its limit in either direction.

If the pressure reading is less than 950 psi (66.7 kpc<sup>2</sup>), remove the acorn nut from the side of the hydraulic control valve and loosen the locknut. Turn the screw clockwise 1/4 turn. Lock nut and recheck the pressure. Readjust, if necessary.

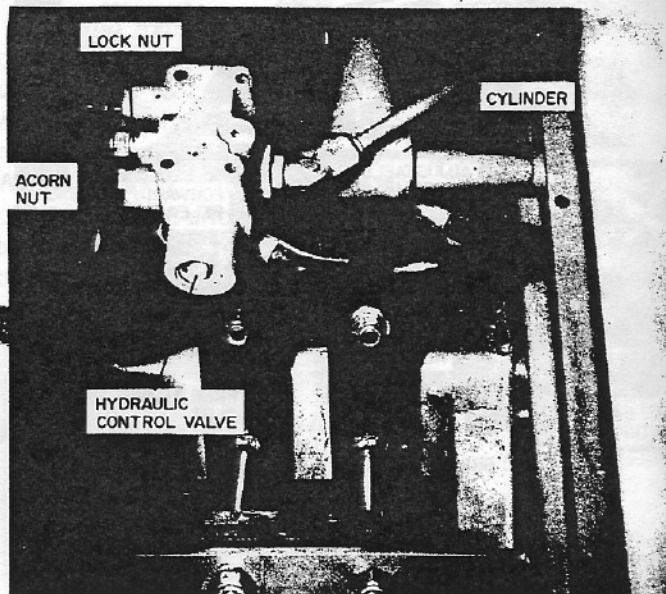

Figure 21

Do not set pressure higher than 1000 psi. If you are unable to set the pressure at 1000 psi (70.3 kpc<sup>2</sup>), either the valve or pump is defective.

Replace the hydraulic pump, add hydraulic fluid, and recheck the hydraulic system.

**CAUTION: DO NOT REUSE THE HYDRAULIC FLUID.**

If the system still does not function correctly, reinstall the original pump and replace the hydraulic valve. Recheck system.

## FUEL SYSTEM

Always use a clean, fresh *REGULAR* grade of gasoline. Leaded or non-leaded type gasoline may be used provided the octane rating is 90 or higher. Use of the non-leaded type gasoline not only lowers emission of air pollutants but results in a considerable reduction of deposits in the combustion chamber. Purchase brand name fuels from popular service stations to eliminate chances of using stale gasoline as this results in formation of gum deposits which can quickly clog carburetor passages. If the tractor is to be stored during an off season, drain the fuel system, run the tank dry or add a gasoline stabilizer to the tank.

Always use a vented fuel tank filler cap and keep the vent open to prevent stoppage of starvation of fuel.

## CARBURETOR

Carburetors are adjusted in the factory and should not have to be reset. If, however, one of the following conditions is noted, readjust carburetor immediately as continued operation with incorrect setting can lead

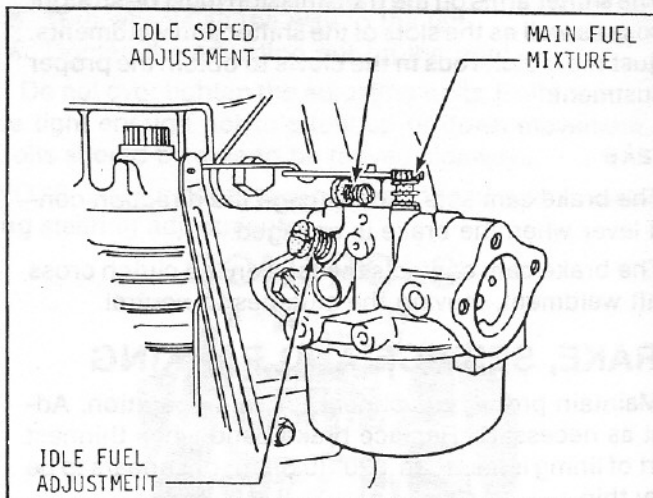

Figure 22 — Side Draft Carburetor

to fouled spark plugs, overheating, excessive valve wear or other problems. If black exhaust smoke is noted, check the air cleaner first — an "overrich" mixture is usually caused by a poorly serviced, clogged air cleaner element, not an improperly adjusted carburetor.

CONDITION	POSSIBLE CAUSE/PROBABLE REMEDY
A. Black, sooty exhaust smoke, engine sluggish.	A. Mixture too rich - readjust main fuel needle.
B. Engine misses and backfires at high speed.	B. Mixture too lean - readjust main fuel needle.
C. Engine starts, sputters and dies under cold weather starting.	C. Mixture too lean - turn main fuel adjustment 1/4 turn counterclockwise.
D. Engine runs rough or stalls at idle speed.	D. Idle speed too low or improper idle adjustment - readjust speed then idle fuel needle if needed.

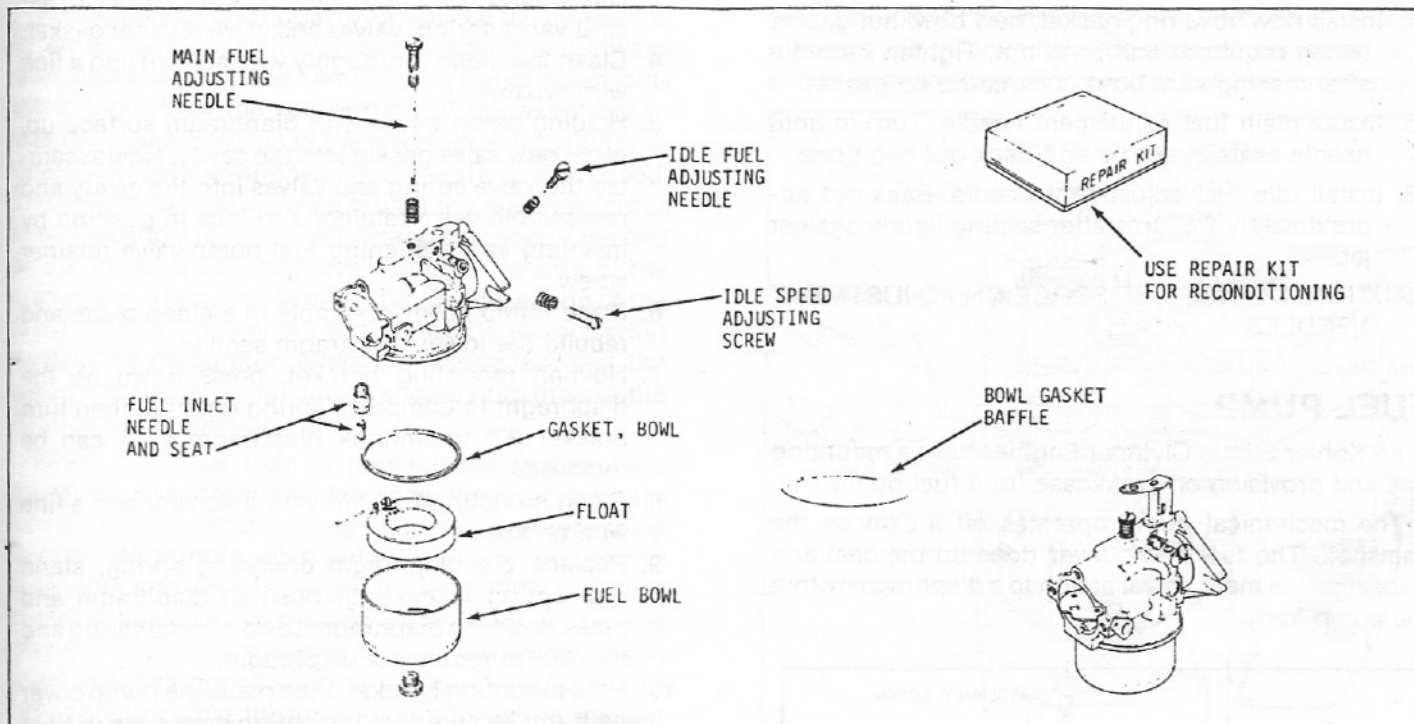

Figure 23 — Side Draft Carburetor

If readjustment becomes necessary, stop the engine, then turn the MAIN and IDLE fuel adjusting screws all the way in until they bottom *lightly* — don't force them closed as this will damage the needle valves. For preliminary setting, turn MAIN fuel screw out (counterclockwise) 2 full turns and the IDLE 1 1/4 turns. For final adjustments, start engine and allow it to warm up then operate at full throttle and under load, if possible. Turn MAIN fuel in until engine slows down (lean side) then out until it slows down again from overrich setting — note positions of screw at both settings, then set it about halfway between the two. The IDLE fuel setting can then be adjusted in the same manner for smoothest idle. Rough idle is often due to the idle speed being set too low — check this also.

**IDLE SPEED:** Idle no-load speed is set for 1200 RPM.

### Carburetor Reconditioning

Service difficulties with fuel systems usually originate from improper carburetor adjustments or dirt, gum or varnish in components. It will be necessary to completely disassemble carburetor to clean thoroughly. Normally only pre-season cleaning will be required; however, the frequency of cleaning will depend upon use and operating conditions.

All parts should be cleaned in a solvent. Gum is easily removed with an alcohol or acetone solvent. Be sure all deposits are removed from bore, especially where throttle plate seats in casting. Blow out all passages with compressed air. Replace all worn and damaged parts. *Always use new gaskets.* Carburetor repair kits are available for carburetors. They include the bowl nut gasket (if required), bowl ring gasket, float pin, bowl baffle gasket and fuel inlet needle and seat.

### Disassembly of Carburetor

1. Remove carburetor from engine.
2. Remove bowl nut, gasket and bowl. When carburetor has bowl drain, remove drain spring, spacer (when used) plug and gasket from inside of bowl.
3. Remove float pin, float, needle and needle seat. Check float for dents, leaks and wear on float lip or in float pin holes.
4. Remove bowl ring gasket.
5. Remove idle fuel adjusting needle, main fuel adjusting needle and springs.
6. *Do not* remove choke and throttle plates and shafts. If these parts are worn, replace carburetor assembly.

## Assembly of Carburetor

1. Install needle seat, needle, float and float pin.
2. Set float level. With carburetor casting inverted and float resting lightly against needle in its seat, there should be  $11/64$ " plus or minus  $1/32$  of an inch clearance between machine surface of casting and free end of float (side opposite needle seat.)
3. Adjust by bending lip of float with small screwdriver.
4. Install new bowl ring gasket, new bowl nut gasket (when required) and bowl nut. Tighten securely after making sure bowl is centered on gasket.
5. Install main fuel adjustment needle. Turn in until needle seats in nozzle and back out two turns.
6. Install idle fuel adjustment needle. Back out approximately  $1\frac{1}{4}$  turns after seating lightly against jet.

**CAUTION: DO NOT USE FORCE ON ADJUSTMENT NEEDLES.**

## FUEL PUMP

All Kohler Single Cylinder Engines have a mounting pad and provision on crankcase for a fuel pump.

The mechanical pump operates off a cam on the camshaft. The fuel pump lever rides on the cam and transmits this mechanical action to a diaphragm within the pump body.

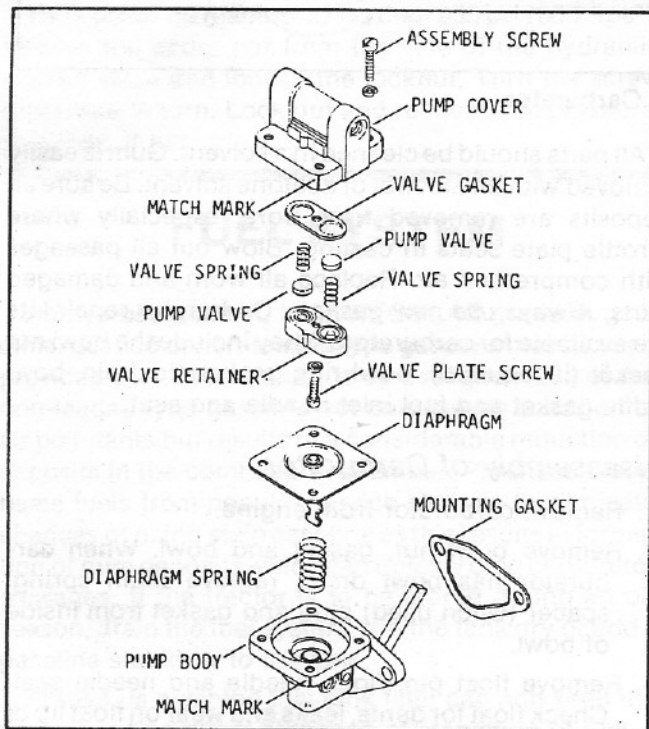

Figure 24 — Fuel Pump

## Reconditioning Procedure:

1. Remove fuel lines and mounting screws holding pump to engine.
2. With a file, make an indicating mark across a point at the union of fuel pump body and cover. This is a positive marking to assure proper reassembly. Remove assembly screws and remove cover.
3. Turn cover over and remove valve plate screw and washer. Remove valve retainer, valves, valve springs and valve gasket, *noting their position*. Discard valve spring, valves and valve retainer gasket.
4. Clean fuel head thoroughly with solvent and a fine wire brush.
5. Holding pump cover with diaphragm surface up, place new valve gasket into the cavity. Now assemble the valve spring and valves into the cavity and reassemble valve retainer and lock in position by inserting and tightening fuel pump valve retainer screw.
6. Place pump cover assembly in a clean place and rebuild the lower diaphragm section.
7. Holding mounting bracket, press down on the diaphragm to compress spring under it, then turn bracket  $90^\circ$  to unhook diaphragm so it can be removed.
8. Clean mounting bracket with a solvent and a fine wire brush.
9. Replace the diaphragm operating spring, stand new spring in casting, position diaphragm and press down on diaphragm to compress spring and turn  $90^\circ$  to reconnect diaphragm.
10. Hold mounting bracket, then place the pump cover on it (make sure that indicating marks are in line) and insert the four screws. **DO NOT TIGHTEN.** With the hand on the mounting bracket only, push the pump lever to the limit of its travel and hold in this position while tightening the four screws. This is important to prevent stretching the diaphragm.
11. Mount the fuel pump on engine, using the new mounting gasket. Connect the fuel lines.

# GOVERNOR SYSTEM

All Kohler Single Cylinder Engines are equipped with centrifugal flyweight mechanical type governors. The governor gear — flyweight mechanism is mounted within the crankcase and driven off a gear on the camshaft.

## Operation

In operation, centrifugal force causes the flyweights to move outward with increase in speed and inward with decreasing speed. As the flyweights move outward, they force the rod portion of the assembly to push outward. Tension of the governor spring pulls the flyweights back inward with decrease in engine speed. The rod, in turn, contacts a tab on the governor cross shaft causing it to rotate with changing speed. One end of the cross shaft protrudes through the side of the crankcase. Through external linkage, the action of the cross shaft is transmitted to the throttle (or butterfly) valve in the carburetor. When the engine is at rest, the tension of the governor spring should hold the throttle valve in open position.

When a normal load is applied and engine (and governor) speed tends to decrease, the resulting rotation of the cross shaft acts against the governor spring to open the throttle valve wider which, in turn, admits more fuel and restores engine speed. With governor properly adjusted, this action takes place so rapidly that a reduction in speed is hardly noticed. As speed again reaches governed setting, the shaft rotates to either open or close the throttle valve to maintain speed at a relatively constant level.

## Adjustment

Governors are adjusted at the factory and further adjustment should not be necessary unless governor arm or linkage works loose and becomes disconnected. Governor readjustment may be indicated if engine speed surges or hunts with changing load or if speed drops considerably when *normal* load is applied.

The following procedure can be used on all models for the initial setting. Make this setting with engine stopped.

- STEP 1: Loosen (do not remove) nut which holds governor arm to the governor cross shaft.
- STEP 2: Grasp end of cross shaft with pliers and turn in counterclockwise direction as far as possible (tab on cross shaft will stop against rod on governor gear assembly).
- STEP 3: Pull governor arm all the way away from carburetor then retighten nut holding governor arm to shaft.

## Sensitivity Adjustment — K241, K301

On the K241, and K301, governor sensitivity can be adjusted by repositioning the governor spring in the holes on the governor arm and speed control brackets. If set too *sensitive*, speed surging will occur with

change of load. If a big drop in speed occurs when normal load is applied, the governor should be set for greater sensitivity.

Normally, the governor spring is placed in the third hole from bottom on the governor arm bracket and in the second hole from top on speed control bracket. To make governor control more sensitive, increase tension on spring by moving spring into holes spaced further apart. Conversely, decreasing spring tension allows broader governor control but less sensitivity.

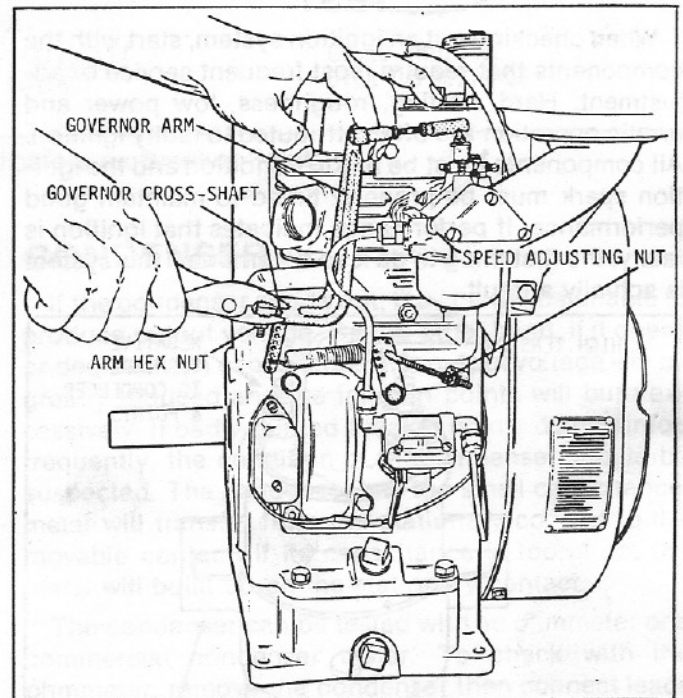

Figure 25 — Initial Adjustment

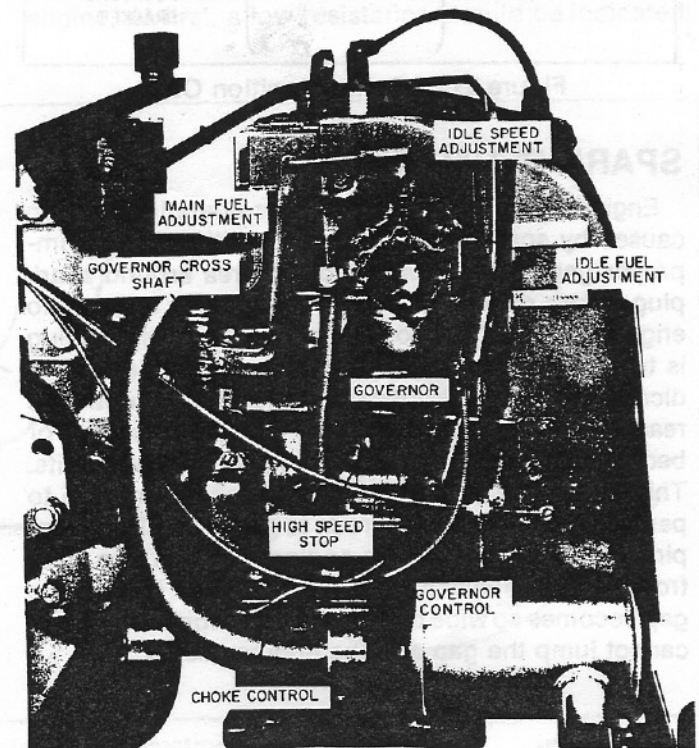

Figure 26

# BATTERY IGNITION SYSTEM

The battery ignition systems function in the same way as the magneto ignition systems, except that the energy source for the ignition coil is the battery. With the alternator systems, a permanent magnet ring on an inside rim of the flywheel revolves around the alternator stator on the bearing plate. This produces Alternating Current but is changed to Direct Current in the rectifier-regulator unit to charge the battery.

## IGNITION SYSTEM OPERATIONAL TEST

When checking out an ignition system, start with the components that require most frequent service or adjustment. Hard starting, roughness, low power and erratic operation are often attributed to faulty ignition. All components must be in top condition and the ignition spark must be properly timed to maintain good performance. If performance indicates that ignition is faulty, the first thing to do is to determine if this system is actually at fault.

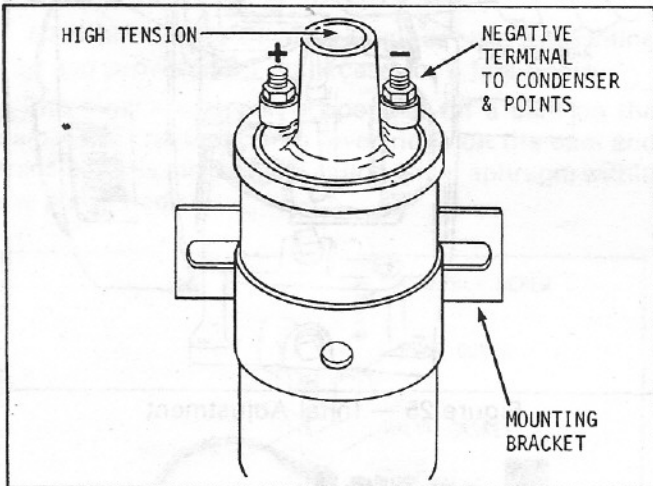

Figure 27 — Battery Ignition Coil

## SPARK PLUG SERVICE

Engine misfire or generally poor operation is often caused by spark plugs in poor condition or with improper gap setting. Always clean area around spark plug before removing to prevent dirt from falling into engine. The first thing to do after removing a spark plug is to carefully note its condition as this is often an indicator of the ignition trouble. Plugs fail for various reasons. Often the porcelain insulator cracks or becomes coated with oil, carbon, or other deposits. This can cause the high voltage ignition impulse to pass from the center electrode to ground without jumping the spark gap. As an engine operates, the electrodes are gradually burned or worn away. In time, the gap becomes so wide that the available ignition voltage cannot jump the gap and the engine misses.

## COMMON CAUSES . . . POOR OR NO IGNITION

### No Ignition Spark

1. Switch turned off
2. Leads disconnected or broken
3. Bad plug
4. Ignition switch faulty
5. Breaker points oxidized
6. Breaker points stuck
7. Condenser faulty
8. Ignition coil faulty

### Poor Ignition

1. Plug Wet
2. Plug gap incorrect
3. Plug carbon fouled
4. Wrong plug
5. Breaker points dirty or bad condition
6. Point gap wrong
7. Condenser weak
8. Push rod sticking or worn
9. Cam lobe worn

### Spark Plug Test

Remove plug, set gap to specifications, place plug with side electrode against cylinder head then crank engine at speed sufficient to produce a good spark — if a sharp snappy spark is noted between the electrodes, this eliminates the ignition components as the fault — wrong timing could however be causing problems.

### Spark Plug Service

Every 100 hours remove plug, check condition and reset gap. Good operating conditions are indicated if plug has light coating of gray or tan deposit. A dead white, blistered coating could indicate overheating. A black (carbon) coating may indicate an "over-rich" fuel mixture caused by clogged air cleaner or improper carburetor adjustment. *Do not* sandblast, wire brush, scrape or otherwise service plug in poor condition — best results are obtained with new plug. Set spark gap at .025". Tighten plug to 18 to 22 foot lbs.

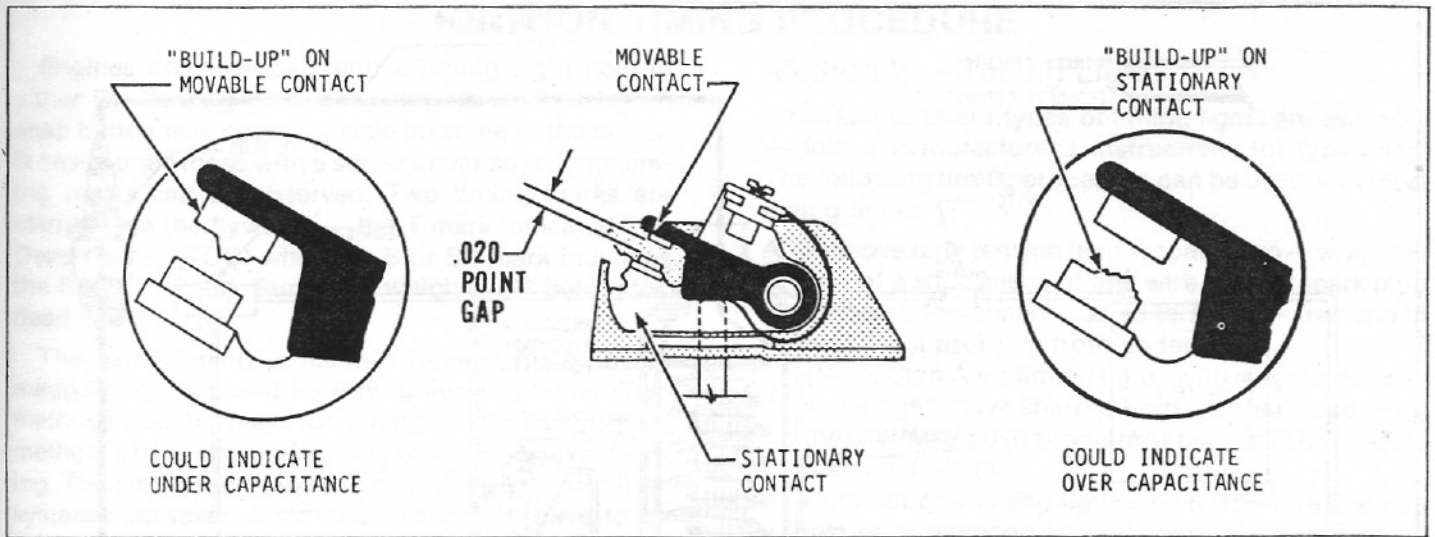

Figure 28 — Metal Transfer Indicators on Breaker Points

### BREAKER POINT SERVICE

Engine operation is greatly affected by breaker point condition and adjustment of the gap. If points are burned or badly oxidized, little or no current will pass and as a result the engine may not operate at all, or if it does run it is likely to miss particularly at full throttle. Adjusting breaker point gap affects the time that the contacts are opened and closed. If the points are adjusted to a wider gap, they will open earlier and close later in terms of cam movement. A definite time is required for the magnetic field within the ignition coil to build up to sufficient value. If the contact points are closed for too short a time, a weak spark will be produced by the coil. If points are set too wide, they will open before the primary current reaches the maximum value and on the other hand if set too close, they will open after the primary current has passed its maximum value.

### CONDENSER

If the condenser shorts out, the coil will be unable to produce output voltage. On the other hand, if it opens or decreases in capacitance, the output voltage will be greatly reduced and the ignition points will burn excessively. If badly burned breaker points do occur too frequently, the condition of the condenser should be suspected. The condenser has too small capacitance, metal will transfer from the stationary contact to the movable contact. If its capacitance is too large, the metal will build up on the stationary contact.

The condenser can be tested with an ohmmeter or a commercial condenser tester. To check with the ohmmeter, remove the condenser then connect leads between the condenser lead and a good ground on the engine. At first, a low resistance should be indicated;

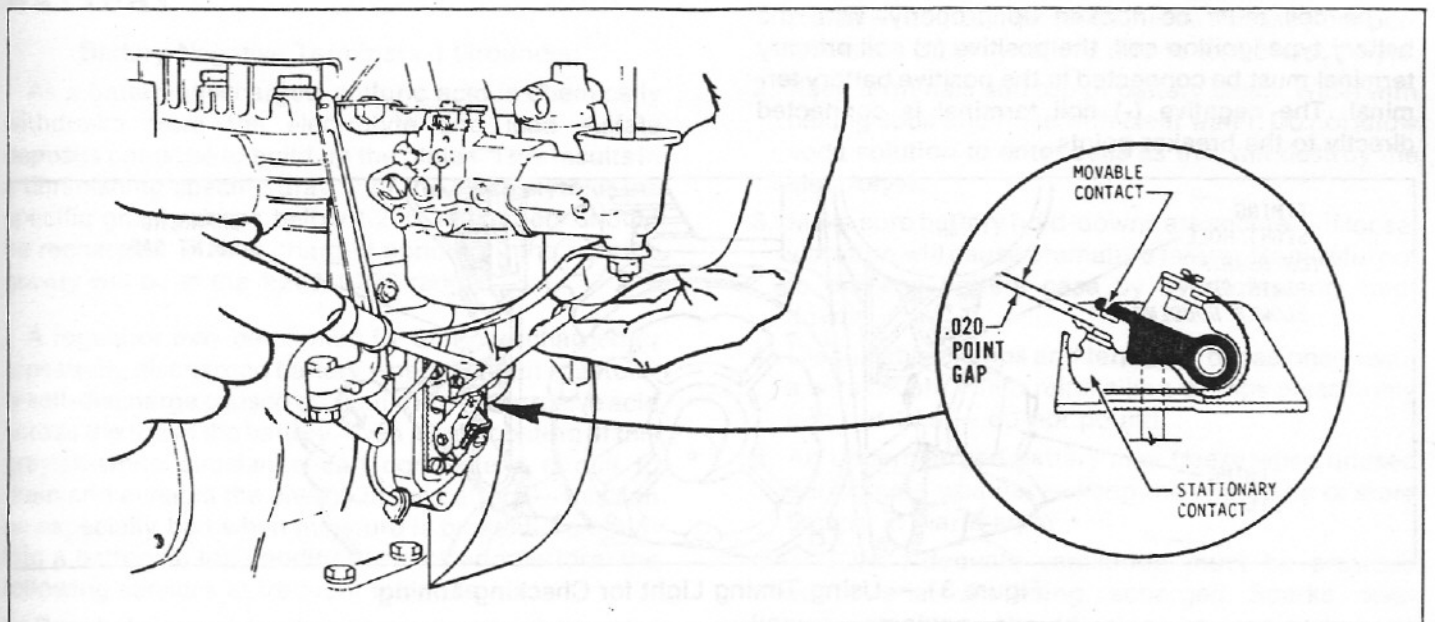

Figure 29 — Breaker Point Gap Adjustment



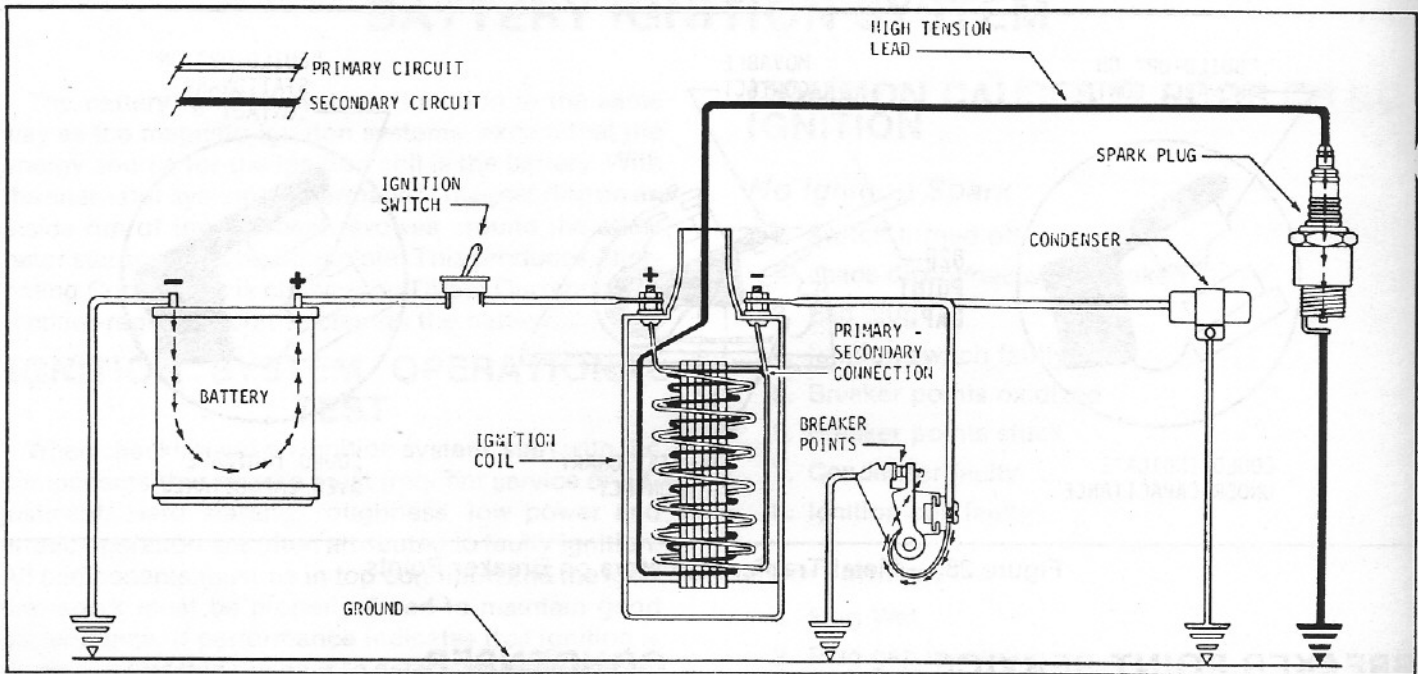

Figure 30 — Schematic - Typical Battery Ignition System

however, this should very quickly rise to a high value. If low resistance is indicated continuously, the condenser is definitely faulty and must be replaced. When using a commercial condenser tester, follow instructions given by the tester manufacturer.

## IGNITION COILS

Ignition coils do not require servicing on a regular basis; however, they should be kept in clean condition and the terminals and connections must be tight to provide good electrical contact. The rubber nipple on the high tension terminal must be in good condition to prevent leakage of current across exposed surfaces.

### Battery Type Ignition Coils

The coil must be hooked up properly. With the battery type ignition coil, the positive (+) coil primary terminal must be connected to the positive battery terminal. The negative (-) coil terminal is connected directly to the breaker points.

## PERMANENT MAGNETS

If the strength of a permanent magnet is suspected as the cause of magneto trouble, a simple rough test will indicate if its field strength is sufficient. With the flywheel removed, place the blade of a screwdriver (non-magnetized) within one inch of the permanent magnet. If the field strength is sufficient, the blade will be quickly pulled to the magnet.

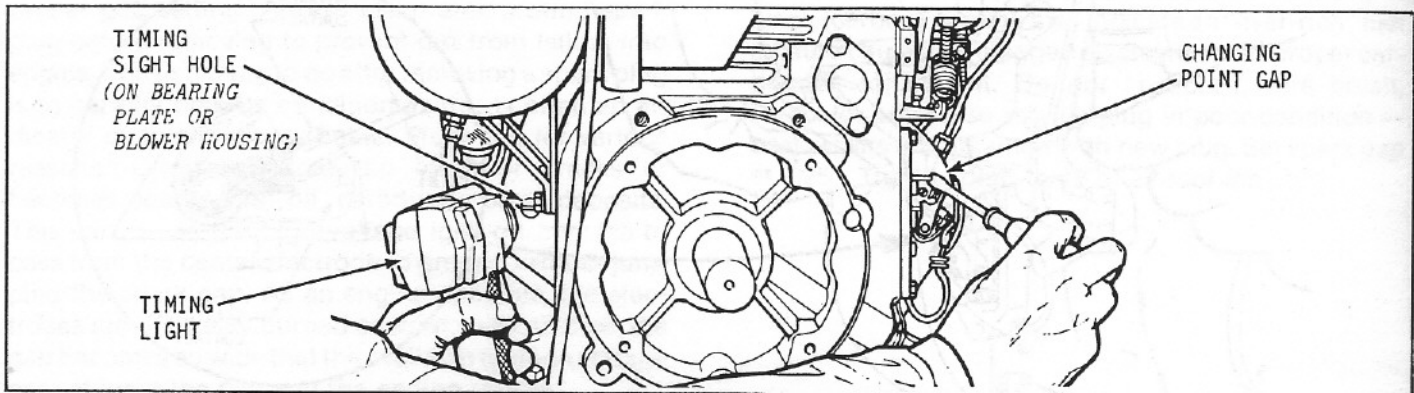

Figure 31 — Using Timing Light for Checking Timing

## IGNITION TIMING PROCEDURE

Engines are equipped with a timing sight hole in either the bearing plate or in the blower housing. A snap button may cover the hole on some — the button is easily pried loose with a screw driver so that the timing marks can be observed. Two timing marks are stamped on the flywheel — the T mark indicated Top Dead Center (TDC) while the S or SP mark indicates the Spark or Spark Run point which is 20° before top dead center.

The same timing procedure is used for both the magneto ignition and battery ignition systems. Two methods can be used for timing — the timing light method is the more precise way of achieving exact timing. The timing light can be used with magneto ignition systems; however, a storage battery will have to be used per timing light manufacturer's instructions.

### Method 1 — static Timing

Remove breaker point cover and remove spark plug lead to prevent unintentional starting. Rotate engine by hand in direction of normal rotation (clockwise when viewed from front or flywheel end). Points should just begin to break as the S or SP mark appears in the center of the timing sight hole. Continue rotating engine until points reach maximum opening. Measure gap with feeler gauge — gap should be .020" fully open. If necessary, loosen point gap adjustment screw and readjust gap to .020" full open. Maximum gap setting can vary a few thousandths (.018-.022") to achieve smoothest running. Securely tighten adjusting screw after timing.

### Method 2 — Timing Light

Several different types of timing lights are available — follow manufacturer's instructions for type used. The following timing procedure can be used with *most* timing lights:

- A. Remove high tension lead at spark plug — wrap one end of a short piece of fine wire around spark plug terminal. Reconnect lead to terminal — free end of wire must protrude from under boot.  
(Note: Step A for timing lights with alligator clips — some lights have sharp prongs on spark lead — on these simply push prong thru boot until it contacts metal connector.)
- B. Connect *one* timing light lead to the wire that has just been wrapped around spark plug terminal.
- C. Connect *second* timing light lead to hot (ungrounded) side of battery — see timing light instructions for battery size, wiring, etc.
- D. Connect *third* timing light lead to ground.
- E. Remove snap button, rotate (by hand) engine until S mark visible — chalk S line for easy reading.
- F. Start engine, run at 1200-1800 RPM, aim timing light into sight hole — light should flash just as S mark is centered in sight hole or even with center mark on bearing plate or blower housing.
- G. If timing is off — remove breaker point cover, loosen gap adjusting screw, shift breaker plate until S mark is exactly centered. Retighten adjusting screws before replacing breaker point cover.

## ELECTRICAL STARTING — CHARGING SYSTEMS

### BATTERY

#### Battery Negative Terminal (-) Grounded

As a battery discharges, sulfuric acid is chemically withdrawn from the electrolyte and lead sulfate deposits continue to build up the plates. This results in a diminishing specific gravity of the electrolyte. If the specific gravity drops below 1.240, the battery should be recharged. In fully charged condition, the specific gravity will be in the 1.260-1.280 range.

A regulator may be blamed for an undercharged or repeatedly discharged battery when the fault is actually self-discharge caused by a build-up of corrosive acid across the top of the battery. Even a light coating of this grayish-white substance can complete a circuit to drain and exhaust the energy in the battery — this can be especially bad when moisture is present. To maintain a battery in top condition, check and perform the following services at frequent intervals.

1. Regularly check level of electrolyte — add water (distilled) as necessary to maintain level above

plates — do not over fill as this can cause poor performance or early failure due to loss of electrolyte.

2. Keep terminals and top of battery clean. Wash with baking soda and rinse with clear water. Do not allow soda solution to enter cells as this will destroy the electrolyte.
3. Make sure battery hold-downs are secure — if loose, vibration will cause premature failure. Be careful not to damage battery case by overtightening hold-downs.
4. Clean cable clamps and terminals occasionally with a wire brush. When reinstalling clamps press firmly into position — do not pound.
5. An undercharged battery may freeze when unused during cold weather — keep the charge up or store battery in warm area.

**CAUTION:** Adequate ventilation must be provided when batteries are being recharged. Sparks, open flames, smoking should also be avoided since hydrogen gas is produced which, if ignited, could cause an internal explosion which could shatter the

<b>CONDITION:</b> NO CHARGE TO BATTERY	POSSIBLE FAULT/REMEDY
<p>TEST A -- With B+ cable connected, check B+ (at terminal on rectifier-regulator) to ground with DC Voltmeter. If 13.8 volts or higher, place minimum load of 5* amps on battery to reduce voltage:</p> <p>A-1 -- If charge rate increases.</p> <p>A-2 -- If charge rate does not increase.</p>	<p>A-1 -- Indicates alternator system OK, battery was fully charged.</p> <p>A-2 -- Check for defective stator or rectifier-regulator (TEST B).</p>
<p>TEST B -- Unplug leads at rectifier-regulator, connect VOM (multimeter) across AC leads, check AC voltage:</p> <p>B-1 -- If less than 28 volts.</p> <p>B-2 -- If more than 28 volts.</p>	<p>B-1 -- Defective stator, replace with new assembly.</p> <p>B-2 -- Defective rectifier-regulator, replace with new unit.</p>
<b>CONDITION:</b> BATTERY CONTINUOUSLY CHARGES AT HIGH RATE	POSSIBLE FAULT/REMEDY
<p>TEST C -- Check B+ to ground with DC Voltmeter:</p> <p>C-1 -- If over 14.7 volts.</p> <p>C-2 -- If under 14.7 volts.</p>	<p>C-1 -- Rectifier-regulator not functioning properly. Replace with new unit.</p> <p>C-2 -- Alternator system OK. Battery unable to hold charge. Check specific gravity of battery. Replace if necessary.</p>

case of the battery. This gas is produced in quantity only while the battery is receiving a high rate of charge but can linger for several hours afterward in a poorly ventilated area.

## ALTERNATOR CHARGING SYSTEMS

15 amp alternator charging system is used. The systems can be easily identified by the rectifier-regulator unit which is mounted on the tractor. The rectifier-regulator as shown on Figure 32.

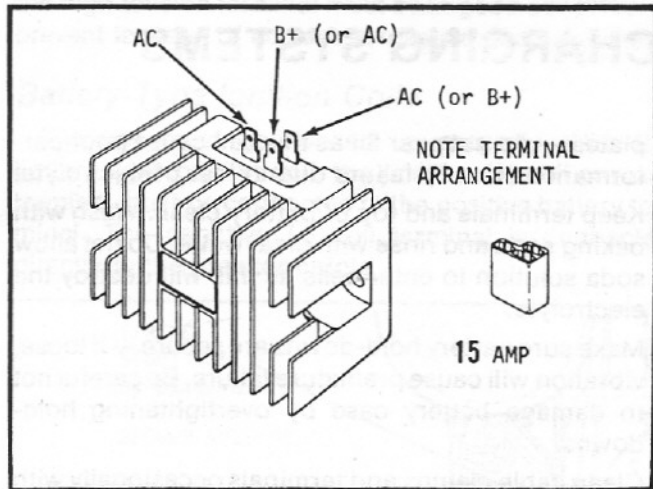

Figure 32

## 15 AMP ALTERNATOR

The 15 amp alternator circuit includes three major components which are: a ceramic magnet ring which is permanently affixed to an inner rim of the flywheel, the alternator stator mounted on the bearing plate of the engine and a rectifier-regulator unit which is mounted either on the engine or on equipment powered by the engine. Terminals on the 15 am rectifier-regulator are

positioned in a different pattern than those on the 10 amp rectifier-regulator to prevent the two systems from being hooked up in error. The 15 amp rectifier-regulator has different solid-state components and therefore cannot be used with any other charging system. The 15 amp unit is slightly larger, physically, than the 10 amp unit. Other main differences are found in the ceramic magnet ring and the alternator stator with more posts and windings which accounts for the higher output than the 10 amp system.

The ceramic ring is permanently assembled with roll pins and compression locking pins on the flywheel first and is then charged magnetically. Because of this and the fact that special tools are required to install the ring, it cannot be ordered or serviced as a separate item. The ceramic material allows better and more complete alignment of magnetic poles of the electrons which thus produces an extremely high strength magnetic field. While ceramic magnets are very strong, the material is brittle and can crack or break if struck with a hard object or when dropped. If the magnets are badly damaged, a new flywheel, complete with new ceramic ring is required — the replacement flywheel must be charged on special equipment at the factory just prior to shipment. When working on engines with this system, avoid any metallic chips or objects that could be attracted to and stick on the magnets.

The stator used with the battery type ignition circuit has 18 posts but only 16 are wound.

**Service:** No adjustments are possible on the alternator system and field service is not recommended. The faulty part should be replaced by a new part. The Trouble Analysis Chart on page 18 can be used to pinpoint the faulty part on a 15 amp system.

**Tests:** There are only a few tests that can be applied to the charging circuit. If the battery is not being charged, check out the battery first for cracked cells, etc. — if the battery proves to be in good condition, that is, the tests reveal it is able to hold charge, the trouble is either in a faulty rectifier-regulator or in the stator windings. Check stator per test procedures outlined in the accompanying trouble shooting chart.

Since the rectifier-regulator will not work (SCR's cannot turn on) without a battery in the system, there are no actual tests that can be performed on this unit with equipment in the field — it will either regulate as required or not function at all.

**Precautions — 15 Amp Systems**

1. Battery polarity must be correct. Negative ground systems are used with Kohler Engines.

2. Prevent alternator leads (AC) from touching or shorting. This could permanently damage the stator.
3. Disconnect leads at rectifier-regulator before electric welding is done on equipment in common ground with engine.
4. Do not operate for any length of time without a battery in the system.

**Pre-Service Procedure**

1. Check to make sure that a good ground is provided between the rectifier-regulator unit and the equipment. This must be in common ground with the engine and battery.
2. Check for and correct poor connections or broken wires.

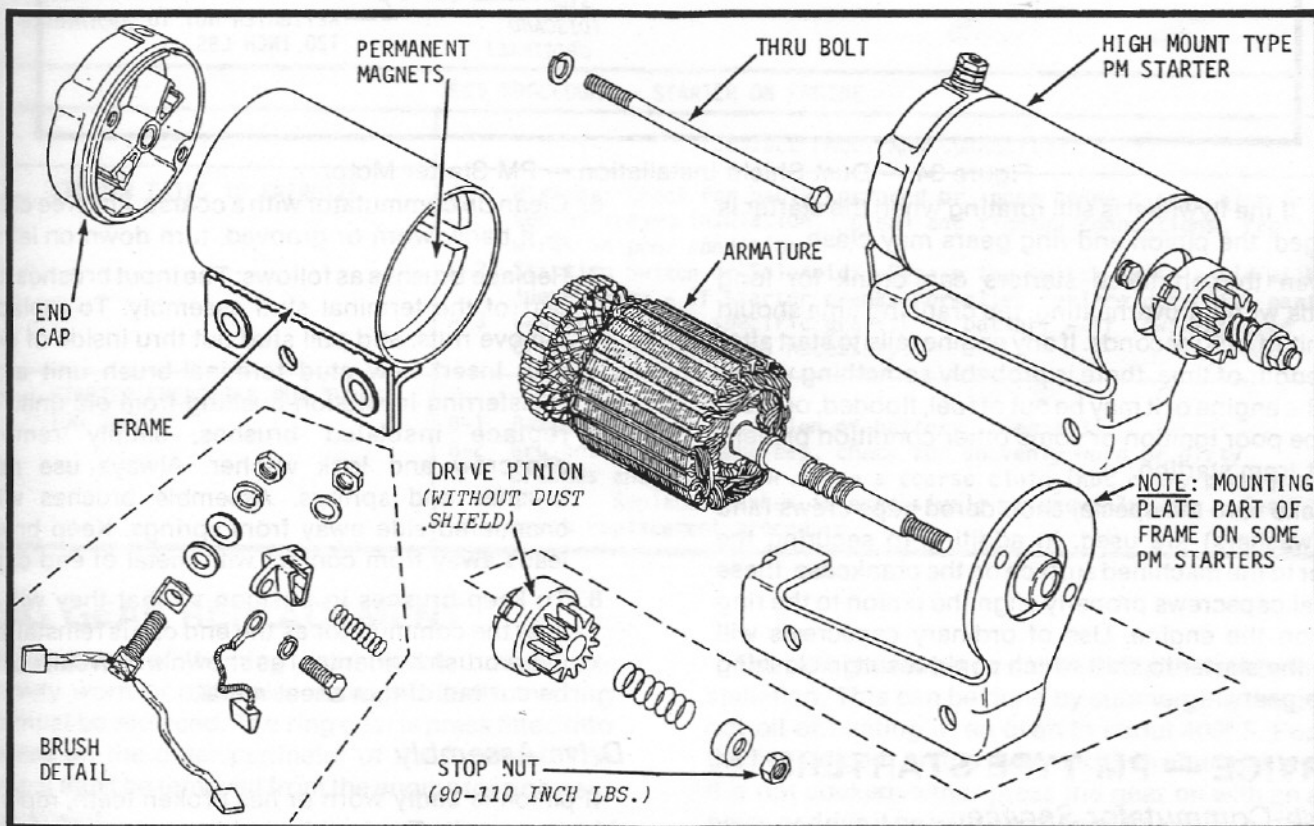

Figure 33 — Permanent Magnet Type Starting Motors - exploded view

**STARTING MOTORS**

**Operation**

On the PM starters, the permanent magnets provide this strong field and only a small current is required to turn the armature. When the starting circuit is closed and the armature starts to rotate, the drive pinion moves laterally on a splined sleeve into mesh with the flywheel ring gear. When the pinion butts against a stop washer at the end of the armature shaft, the pinion rotates along with the armature to crank the engine. The armature and pinion remain in positive engagement until the engine fires and attains the speed where

the flywheel begins overriding the armature. At this instant, the greater momentum of the flywheel throws the pinion out of mesh and back into the retracted or disengaged position. After the starting circuit is opened and as the armature coasts to a stop, a small anti-drift spring holds the pinion in the retracted position.

**Precautions**

In the event of a "false start", that is, if the engine gets up sufficient speed to disengage the starter but then fails to continue running, the engine must be allowed to come to a complete halt before a restart attempt is

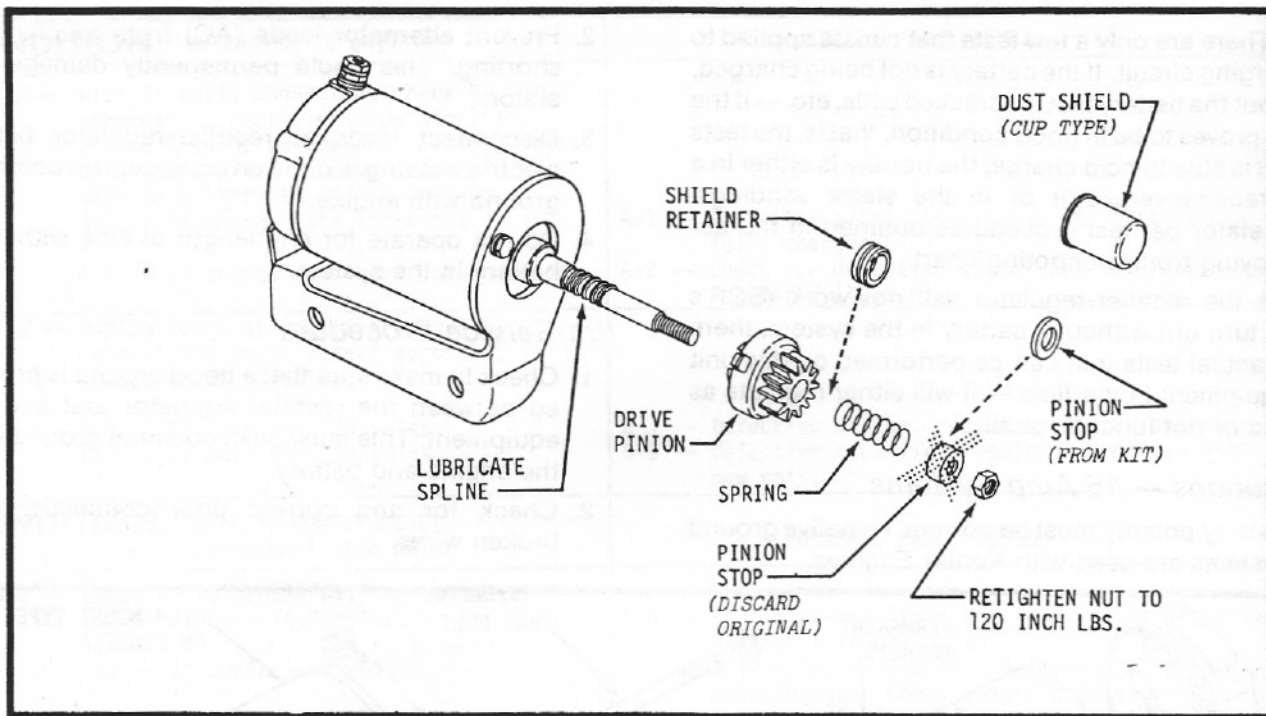

Figure 34 — Dust Shield Installation — PM Starter Motor

made. If the flywheel is still rotating when the starter is engaged, the pinion and ring gears may clash.

- Even though these starters can crank for long periods without overheating, the cranking time should be limited to 60 seconds. If any engine fails to start after this length of time, there is probably something wrong with the engine or it may be out of fuel, flooded, or there may be poor ignition or some other condition preventing it from starting.

- Make sure the special shouldered caps crews (and lock washers) are used. In addition to securing the starter to the machined surface on the crankcase, these special capscrews properly align the pinion to the ring gear on the engine. Use of ordinary capscrews will allow the starter to shift which could result in clashing of the gears.

## SERVICE — PM TYPE STARTERS

### Brush-Commutator Service

The starter must be completely disassembled to service brushes and commutator; however, disassembly can be done quickly and easily. Proceed as follows:

1. Remove drive pinion unit.
2. Remove thru bolts.
3. Remove end bracket capscrew from end cap, then turn bracket so that it will not interfere with removal of mounting bracket.
4. Slip mounting bracket and frame off over drive end of armature.
5. Separate end cap from armature — **NOTE:** Brush springs will probably fall out when brushes pull free of the commutator.

6. Clean up commutator with a coarse, lint-free cloth — if badly worn or grooved, turn down on lathe.
7. Replace brushes as follows: The input brushes are part of the terminal stud assembly. To replace, remove nuts, and pull stud out thru inside of end cap. Insert new stud terminal-brush unit after transferring insulation bushing from old unit. To replace insulated brushes, simply remove capscrew and lock washer. Always use new brushes and springs. Assemble brushes with chamfered side away from springs. Keep brush leads away from contact with metal of end cap.
8. To keep brushes in position so that they will fit over the commutator as the end cap is reinstalled, use a brush holder tool as shown which can easily be cut out of thin sheet metal.

### Drive Assembly

If pinion is badly worn or has broken teeth, replace drive as a unit. To do this, hold armature shaft and remove stop nut, spacer, anti-drift spring, then slip drive unit off over spline and armature shaft. Leave new drive unit off if further disassembly of starter is required — drive unit is the last part to be reinstalled. Reverse procedure to reinstall drive unit — tighten stop nut to 90-110 lbs. Do not lubricate spline (unless dust shield is used) as dust may build up here and cause sticking.

### Dust Shields

Kits are available for adding dust shields to the permanent magnet type starting motors. The dust shield is recommended for all applications where dust and oil could build up on the drive shaft and cause the drive pinion to stick. When the shield is used, the drive shaft can be lubricated which improves its operation. The

kits should also be used to replace dust shields on starters which already have the shield.

Each kit includes a new pinion stop, a dust shield retainer and a dust shield. The dust shield can be quickly added after the starter is removed from the engine.

1. Remove the drive nut, pinion stop and spring — discard the stop.
2. Thoroughly clean the drive shaft and pinion then apply a small amount of Lubriplate AERO grease (or equivalent) to the shaft.
3. Install the shield retainer next to the drive pinion as shown, install the spring and pinion stop (from kit) then reinstall and tighten the retaining nut to 120 in. lbs. torque.
4. Push the dust shield on until it snaps into position over the shield retainer. This completes the installation.

5. When reinstalling the starter, make sure the shoulder capscrews are used as these establish alignment of the drive pinion to ring gear.

### Trouble Analysis

Problems that can occur during normal usage are listed in the accompany chart. The symptom, possible cause and the suggested remedy are stated. If these steps do not solve the problem, the starting motor should be replaced. Replacement of the end cap assembly, which includes the negative brush and spring, is the only recommended field service that requires partial disassembly of the motor.

TEST PROCEDURE - STARTER ON ENGINE	
CONDITION	POSSIBLE FAULT AND CORRECTION
A. STARTER FAILS TO ENERGIZE	A-1 Wiring: Check for badly corroded or loose connections, also broken or frayed insulation. Clean and tighten connections, replace wires in poor condition. A-2 Starting Switch or Solenoid: Bypass the switch or solenoid with jumper wire - if starter cranks normally, replace defective part. A-3 Battery: Check specific gravity of battery - if low, recharge or replace battery as necessary.
B. STARTER ENERGIZES BUT TURNS TOO SLOWLY	B-1 Battery: Check condition of battery (See A-3). B-2 Brushes: Remove end cap, check for unevenly worn or dirty brushes and commutator. Use a coarse cloth (not emery paper) to clean. Replace brushes if excessively or unevenly worn. See brush replacement procedure.

## RING GEAR REPLACEMENT

If inspection of the ring gear reveals broken, excessively worn or otherwise damaged teeth, the ring gear must be replaced. The ring gear is press fitted into a recess on the outer perimeter of the flywheel. The flywheel must be removed from the engine for ring gear replacement.

Several methods may be used to remove the damaged ring gear. One method is to break the gear into sections with a cold chisel and/or a hack saw. Another way to heat the ring gear with a torch, then drive the gear off the flywheel. If the latter method is used, the flywheel will also absorb some heat and it must be allowed to cool before the new ring gear can be installed.

The new gear must be expanded with heat before installation. This can be done by submerging the gear in hot oil or heating in an oven to about 400° F. Position the heated gear on the flywheel, then after making sure it is not cocked, either press the gear on with an arbor press or drive it on with a soft head hammer. As the gear cools, it will contract to form a tight press fit on the flywheel. Be sure to tighten the flywheel retaining nut to the proper torque value after reinstalling the flywheel on the engine.

# ENGINE — GENERAL SERVICE

## COOLING

Air is drawn into the cooling shroud by fins provided on the flywheel. The rotating air screen and the cooling fins on the block and cylinder head must be kept clean and unobstructed at all times. *Never operate engine with blower housing or cooling shrouds removed.* These direct air flow past cooling fins. Removal results in improper air circulation.

## EXTERNAL SURFACES

External surfaces must be maintained in clean condition free of any oil and dirt accumulation. This is done not only for safety and appearance but because poor cooling efficiency results from dirty external surfaces.

## ENGINE TESTS

### Crankcase Vacuum Test

A partial vacuum should be present in the crankcase when engine is operating at normal temperatures. An engine in good condition will have crankcase vacuum of 5 to 10" water column as read on "U" tube water manometer or ½ to 1" Hg. as calibrated on mercury vacuum gauge. Crankcase vacuum check is best accomplished with the "U" tube manometer. If vacuum is not in the specified range, this could be attributed to one or more of the following factors — the condition easiest to remedy should be checked first:

- A. *Clogged Crankcase Breather* can cause positive pressures to build up in the crankcase. Disassemble breather assembly, thoroughly clean, then recheck pressure after re-installing.
- B. *Worn oil seals* can cause lack of vacuum. Oil leakage is usually evident around worn oil seals. (See Oil Seal Replacement Instructions)
- C. *Blowby, leaky valves* can also cause positive pressures. These conditions can be confirmed by making compression test on engine.

### Construction — "U" Tube Manometer

Vacuum gauges, mercury and water manometers are available commercially. A water "U" tube manometer is simple to construct if limited usage does not warrant purchase of commercial product. To construct water manometer, proceed as follows:

- (a) Procure length of clear plastic tubing. Bend tube to form "U" and mount on board as shown in accompanying illustration. Make gradual, rather than sharp bend in tube.
- (b) Measure inside, straight section of tube and mark inch increments from 0 to 12".
- (c) Procure cork having outside diameter which will be a snug fit in the oil fill hole. Drill hole in center of cork to receive one end of tube.
- (d) Pour water (colored for easier reading) into tube

until level reaches the approximate halfway mark on scale.

When using manometer, place cork end into oil fill hole (other end open to atmosphere) and measure difference between columns. If water column is higher in tube connected to engine, vacuum or negative pressure is indicated. If the higher column is on the atmospheric side of manometer, positive pressure is present.

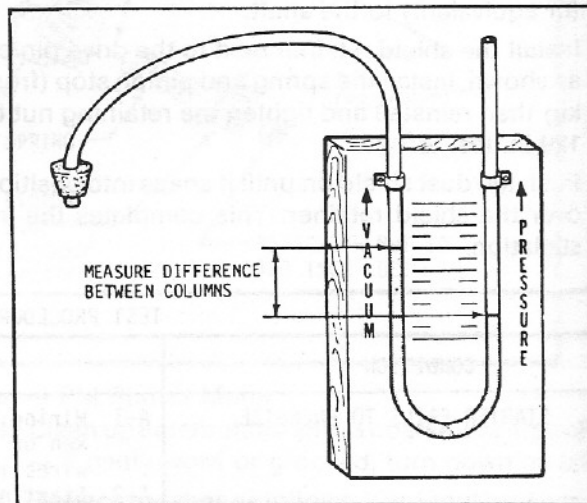

Figure 35 — U-Tube Manometer

### Compression Test

The results of a compression check can be used to determine if an engine is in good operating condition or if reconditioning is needed. *Low readings* can indicate several conditions or a combination of the following conditions:

Higher than normal compression can indicate that excessive carbon deposits have built up in the combustion chamber.

A simple "feel" test can be used as a "spot check" if poor compression is suspected as the reason for hard starting and lack of power. If results of test point to poor compression — this test should be followed up with the more precise and accurate test method using a compression gauge.

#### Method 1 — Spot Check (without gauge)

Remove high tension lead from the spark plug.

On ACR engines, rotate flywheel backwards (counterclockwise direction) against power stroke — if little or no resistance is felt, check with compression gauge.

#### Method 2 — Compression Gauge Test

- A. Remove spark plug and insert compression gauge in hole.
- B. Engine will have to be motored to a speed of about 1000 RPM. Hold throttle wide open and take several compression readings. Consistent readings of 110 to 120 psi indicate good compression.

LOW COMPRESSION	
POSSIBLE CAUSE	REMEDY
A. Cylinder head gasket blown.	A. Remove head, replace gasket, reinstall head, recheck compression.
B. Cylinder head warped or loose.	B. Remove head, check for flatness (see cylinder head service), reinstall and secure in proper sequence to specified torque value.
C. Piston rings worn - blowby occurring.	C. Recondition engine.
D. Valves leaking.	D. Recondition engine.

## INSPECTION — DISASSEMBLY

When disassembling an engine, carefully inspect and note the physical appearance of each of the components. Often the appearance of parts will indicate operation under other than ideal conditions. In observing these indicators, you may be able to suggest improved service and operating techniques which will result in prolonged engine service life. Some of the things to look for are:

1. Excessive sludge and varnish formation.
2. Scoring of the cylinder walls.
3. Severe piston damage.
4. Evidence of external oil leakage.

Sludge is a natural by-product of combustion and a small accumulation is normal. Excessive sludge formation could indicate several things. The most common cause is perhaps too infrequent lubricating oil changes. It can also indicate operation with improper ignition timing or overrich carburetor adjustment or a poorly serviced clogged air cleaner which restricts air intake and also results in an overrich mixture.

### *Scoring of the Cylinder Wall*

Unburnt fuel not only adds to sludge formation but can, in severe cases, cause scuffing and scoring of the cylinder walls. As raw fuel seeps down the cylinder walls, it washes the necessary lubricating oils off the piston and cylinder walls so that the piston rings make metal to metal contact with the walls. Scoring of the cylinder walls can also be caused by localized hot spots resulting from blocked cooling fins or from inadequate or contaminated lubrication.

### *Severe Piston Damage*

Major damage to pistons and rings can take various forms. The top of the piston ring may be burned through or the top groove may be excessively worn and the ring broken or stuck in the groove. This can be attributed to abnormal combustion. If ignition timing is overadvanced, ignition will occur while the piston still has a long distance to travel on its compression stroke. As a result, the combined heat of compression plus the heat of pre-ignited fuel raises temperatures to values comparable to that of an acetylene torch. This, of course, acts mainly on the top land and top ring of the piston and results in early failure.

### *Evidence of External Oil Leakage*

If excessive oil leakage is evident, this may indicate improperly serviced breather systems. Normally, an engine operates internally at pressures under atmospheric or, in other words, with a negative crankcase pressure. If positive pressures build up within the crankcase from a clogged breather or from piston blow-by, oil will be forced out of an engine at oil seals, gaskets or any other available spot.

These are just a few of the more common indicators. Numerous others exist and are obvious to the experienced mechanic. Often the cause will become apparent in view of the particular condition of the part. Always look for these signs when disassembling an engine prior to reconditioning.

## REPAIR-REPLACEMENT METHODS

There are several different methods to choose when repairing a failed single cylinder engine. If you have complete shop facilities to rebore cylinders and regrind crankshafts, you may choose to completely *overhaul* the engine using appropriate oversize and/or undersize replacement parts. If the bore, piston, connecting rod are damaged but the crankshaft and all other parts are in good condition, the *miniblock* may be the best repair method.

If an engine is in bad shape, both internally and externally, consider *replacing* it with a basic catalog engine if available for the engine spec involved. These repair and replacement methods are described briefly in the following.

### *Miniblock*

A miniblock could be considered as a "crankless" short block since it has the same items except that the crankshaft and bearing plate assembly are omitted. Omitting these items not only reduces costs but allows the miniblock to be used in place of a short block in cases where the short block crankshaft is not suitable for the particular application. The crankcase-bearing plate assembly must be in condition to be reused on the miniblock.



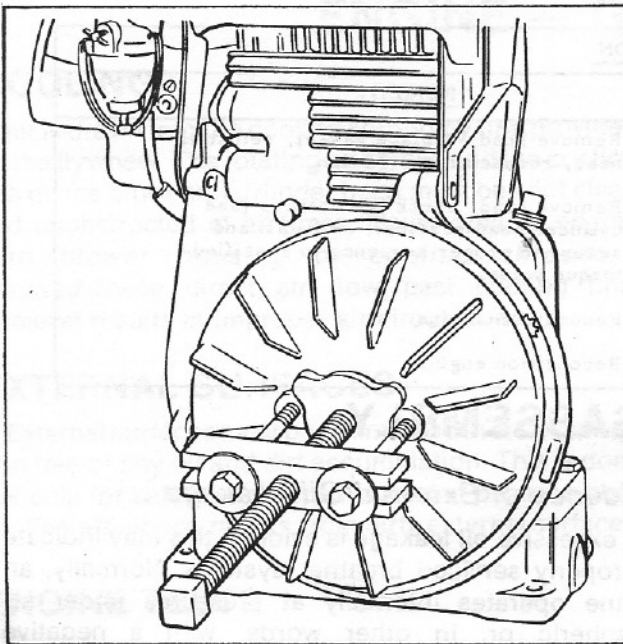

Figure 36 — Removing Flywheel with Puller

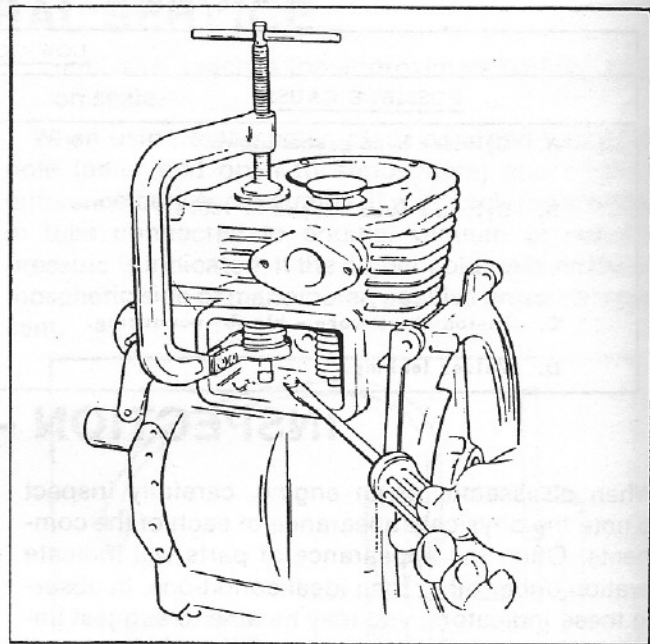

Figure 37 — Using Valve Compressor

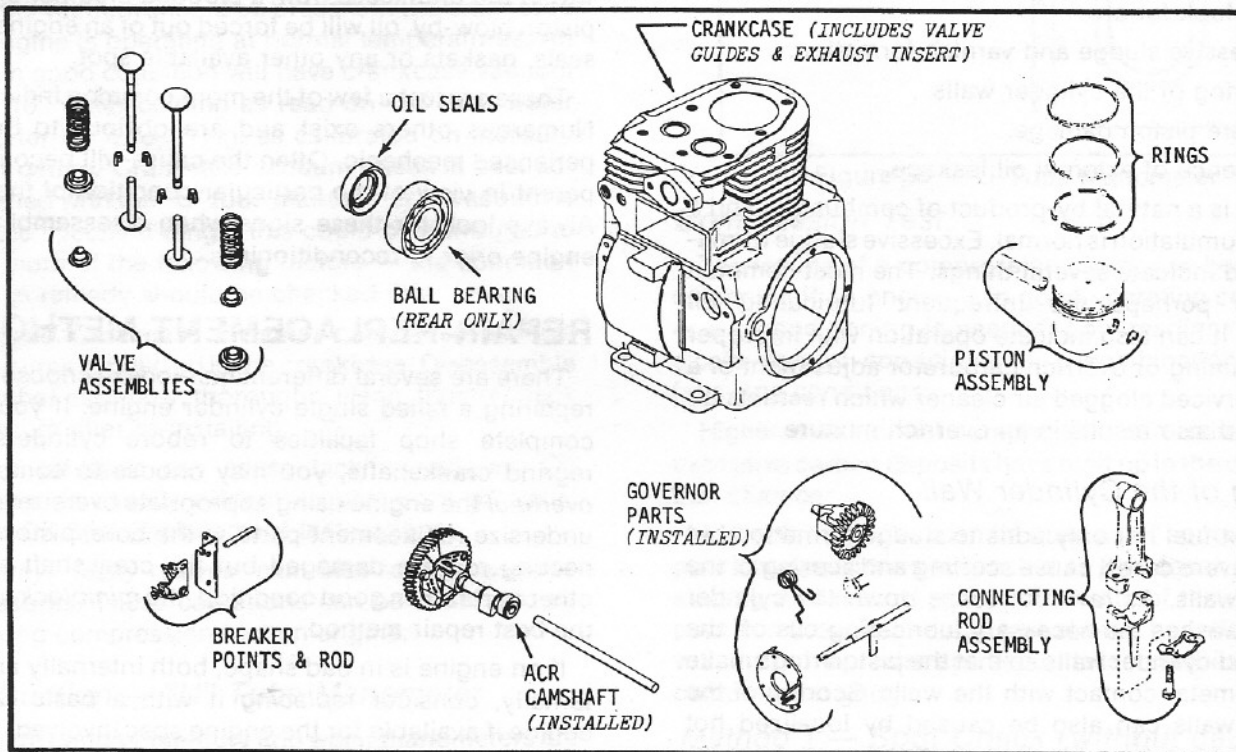

Figure 38 — Components of a Typical Miniblock Assembly

## DISASSEMBLY PROCEDURE

1. Disconnect lead and remove spark plug.
2. Remove fuel line at carburetor.
3. Remove air cleaner from carburetor intake.
4. Remove carburetor.
5. Remove blower housing, cylinder baffle and head baffle.
6. Remove rotating screen and starter pulley.
7. Flywheel is mounted on tapered portion of the crankshaft. Use of a puller is recommended for removing flywheel. Bumping end of crankshaft with hammer to loosen flywheel should be avoided as this can damage crankshaft.
8. Remove breaker point cover, breaker point lead, breaker assembly and push rod.
9. Remove magneto assembly.
10. Remove valve cover and breather assembly.
11. Remove cylinder head.
12. Raise valve springs with a spring compressor and push valve keepers off valve stems. Remove valve spring retainers, springs and valves.

13. Remove oil base and unscrew connecting rod cap. Remove piston assembly from cylinder block.
14. Remove crankshaft, oil seals and, if necessary, anti-friction bearings. It may be necessary to press crankshaft out of cylinder block. Bearing plate should be removed first if this is done.
15. Turn cylinder block upside down and, using a small punch, drive camshaft pin out from power-take-off side of engine. Pin will slide out easily after it is driven free of block.
16. Remove camshaft and valve tappets.
17. Loosen and remove governor arm from governor shaft.
18. Unscrew governor bushing nut and remove governor shaft from inside of cylinder block.
19. Loosen (do not remove) screw located to lower right of governor bushing nut until governor gear is free to slide off stub shaft.

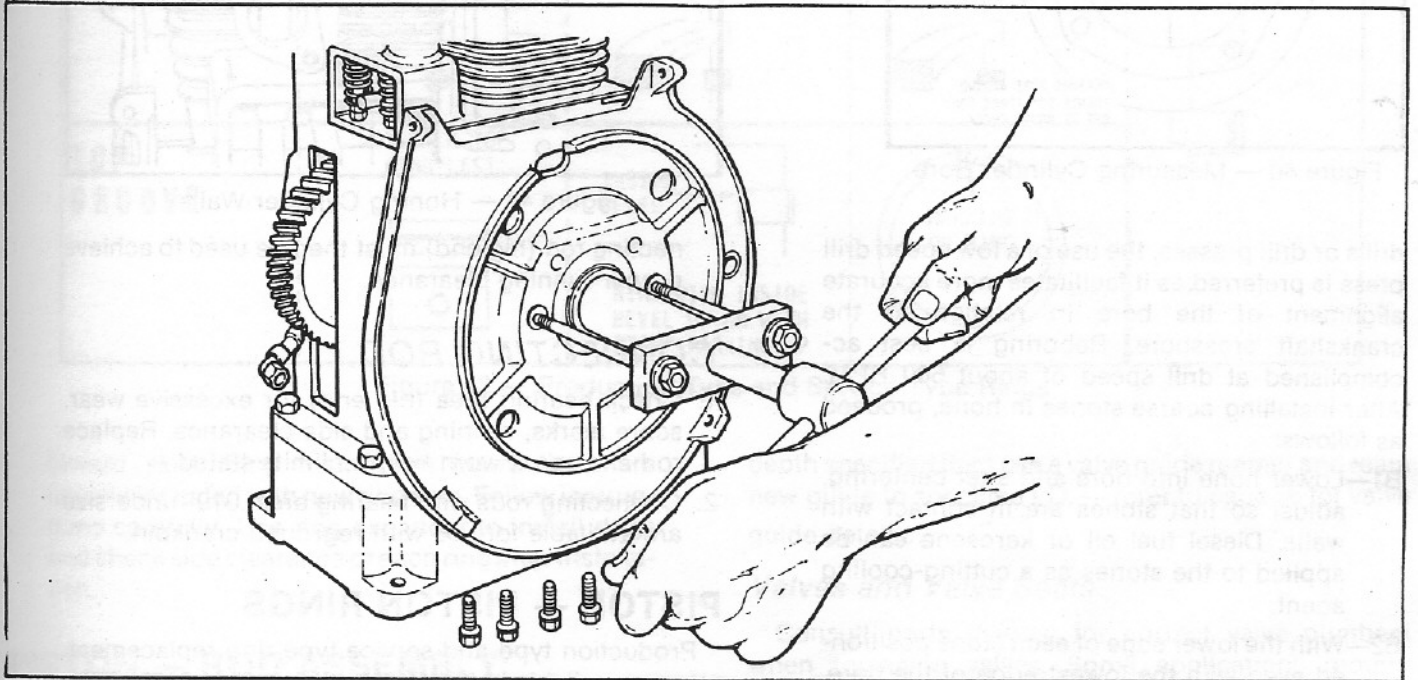

Figure 39 — Removing Bearing Plate with Puller

## ENGINE RECONDITIONING

All parts should be thoroughly cleaned — dirty parts cannot be accurately gauged or inspected properly for wear or damage. There are many commercially available cleaners that quickly remove grease, oil and grime accumulation from engine parts. If such a cleaner is used, make sure that all trace of the cleaner is removed before the engine is reassembled and placed in operation. Even small amounts of these cleaners quickly break down the lubricating properties of engine oils.

### CYLINDER BLOCK

#### 1. Inspection

- A. *Gasket surfaces* — Check all surfaces to make sure that they are free of gasket fragments and sealer materials. Surfaces must also be free of deep scratches or nicks.
- B. *Bearings* — (Crankshaft) — One bearing is pressed into the cylinder block — the other is located in the bearing plate. Do not remove bearings unless they show signs of damage and are to be replaced. (See Reconditioning —

Cylinder Block.) If the bearings turn easily and noiselessly and there is no evidence of scoring or grooving on the races, the bearings can be reused.

- C. *Cylinder bore* — If badly scored, excessively worn or tapered or out of round more than .005, reboring is necessary. Use an inside micrometer to determine amount of wear (See Fits and Clearance Section). If cylinder bore is not damaged and is within tolerances, only light deglazing may be necessary.

#### 2. Reconditioning — Cylinder Block

- A. Remove old oil seal from block but do not install new seal until after crankshaft is reinstalled.
- B. *Reboring procedure* — See Clearance Section for original cylinder bore size. Use an inside micrometer to measure wear then select nearest suitable oversize of either .010, .020 or .030". Reboring to one of these oversizes will allow usage of the available oversize piston and ring assemblies. While most commercially available cylinder bores can be used with either portable

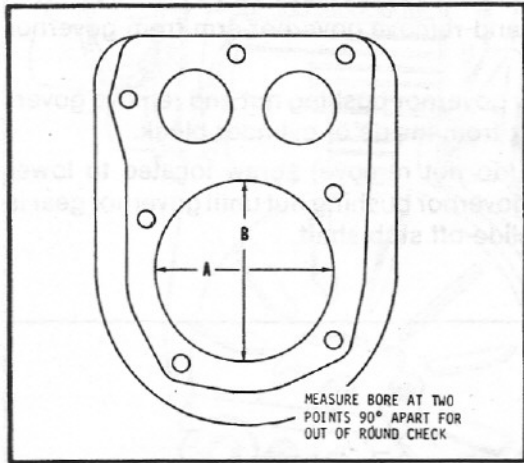

Figure 40 — Measuring Cylinder Bore

drills or drill presses, the use of a low speed drill press is preferred as it facilitates more accurate alignment of the bore in relation to the crankshaft crossbore. Reboring is best accomplished at drill speed of about 600 RPM. After installing coarse stones in hone, proceed as follows:

- B1—Lower hone into bore and after centering, adjust so that stones are in contact with walls. Diesel fuel oil or kerosene can be applied to the stones as a cutting-cooling agent.
- B2—With the lower edge of each stone positioned even with the lowest edge of the bore, start drill and honing process. Move hone up and down while reboring to prevent formation of cutting ridges. Check size frequently.
- B3—When bore is within .0025 of desired size, remove coarse stones and replace with burnishing stones. Continue with burnishing stones until within .0005 of desired size then use finish stones and polish to final size.
- B4—After reboring, carefully clean cylinder wall with soap and water, then after drying thoroughly, apply light coat of SAE 10 oil to prevent rust.

## CRANKSHAFT

1. *Keyways — Gears* — If keyways for flywheel are badly worn or chipped, replacement of the crankshaft may be necessary. Broken or badly worn cam gear teeth will also necessitate replacement of shaft.
2. *Crankpin* — Inspect crankpin for score marks or metallic pickup. Slight score marks can be cleaned with corcus cloth soaked in oil. If wear limits, as stated in Clearance Section, are exceeded by more than .002", it will be necessary to either replace crankshaft or regrind the crankpin to .010" undersize. If wear is moderate, the .010" undersize con-

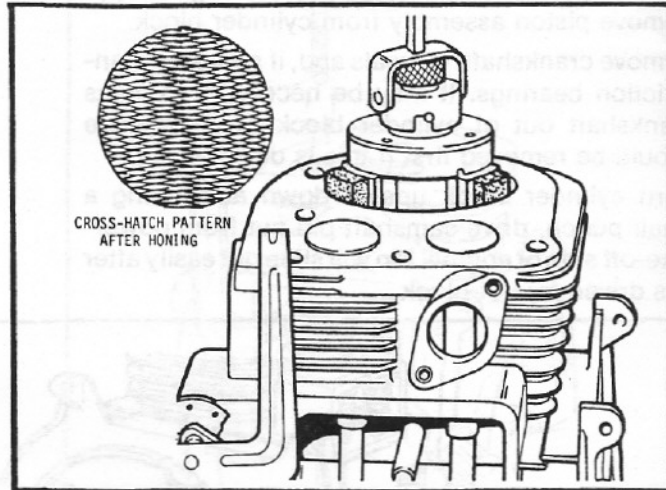

Figure 41 — Honing Cylinder Walls

necting rod (big end) must then be used to achieve proper running clearance.

## CONNECTING ROD

1. Check bearing area (big end) for excessive wear, score marks, running and side clearance. Replace rod and cap if worn beyond limits stated.
2. Connecting rods with bearing area .010" undersize are available for use with reground crankpin.

## PISTON — PISTON RINGS

Production type and service type ring replacement sets are available in the standard size plus .010", .020" and .030" oversize sets. The production standard type set is used only when cylinder is not worn or out of round. Production oversize sets are used only when cylinder has been rebored to the corresponding oversize. Service type sets are used when cylinder is worn but within wear and out of round limits (wear limit .005" oversize, out of round limit .004"). Service sets usually include expanders or other arrangement to provide uniform pressure on ring and better conformity to cylinder wall regardless of wear. Cylinder bore must be deglazed before service ring sets are used. Chrome plated rings, when used, should be installed in the top groove.

1. If the cylinder block does not need reboring and if the old piston is within wear limits and free of score or scuff marks, it may be reused. *Never* reuse old rings, however.
2. Remove old rings and clean up grooves.
3. Before installing new rings on piston, place each ring in turn in its running area in cylinder bore and check end clearance.
4. Rings must be installed according to markings or rings. Generally compression rings must be installed with groove or bevel up when this is on inside diameter of ring. The chrome ring, when used, must be installed in the top groove. When bevel is on outside of ring, install in down position or

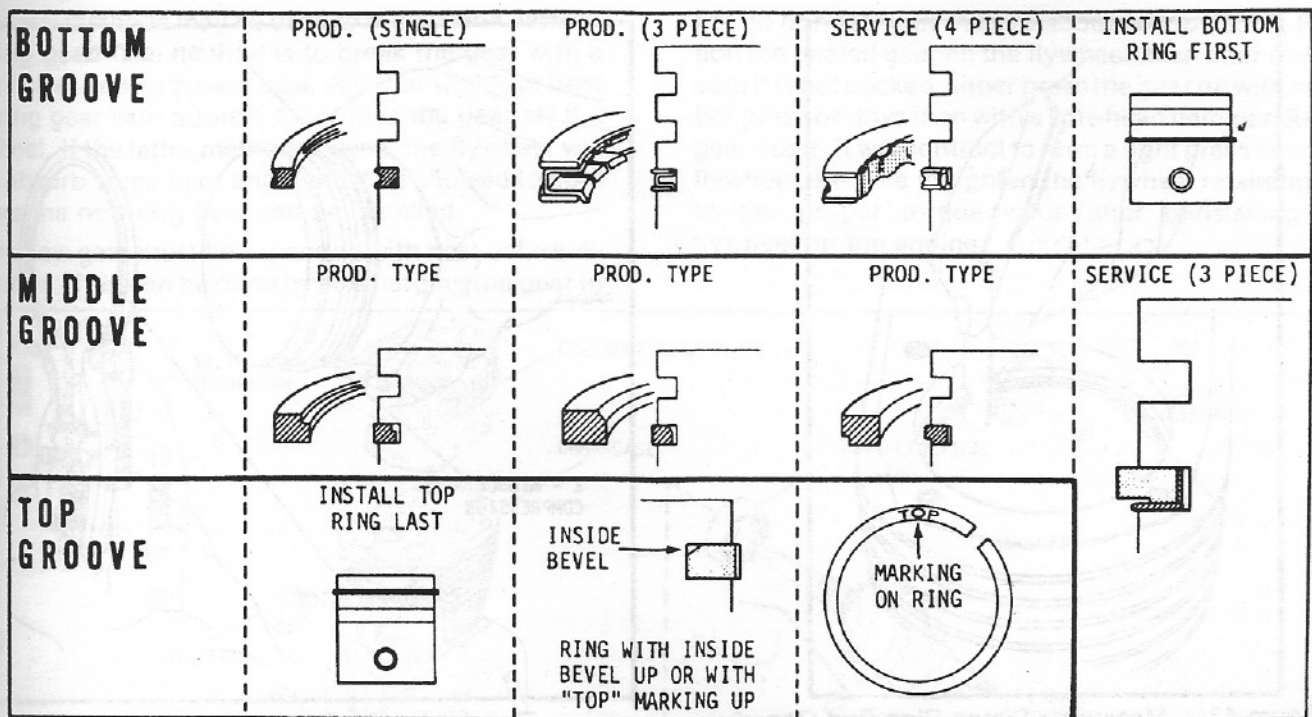

Figure 42 — Production Type and Service Type Rings

toward skirt. Ring installation instructions are usually included with new ring sets. Follow instructions carefully. Use ring expander to install rings and check side clearance of each ring after installation.

## PISTON — ROD ASSEMBLY

Normally very little wear takes place in the piston boss-piston pin area. If the original piston and connecting rod can be reused after reconditioning, the pin will usually not have to be replaced. A new piston pin should be used when a new connecting rod is used with the original piston. After checkin pin, rod and piston boss to make sure proper clearance are available, lubricate pin then assemble piston to rod with pin (light interference to loose fit) and lock pin with *new retainers* — make sure retainers are fully engaged in grooves.

## VALVES — VALVE MECHANISM

Carefully inspect valve mechanism parts. Check valves and valve seat area or inserts for evidence of deep pitting, cracks or distortion. Check clearance of valve stems in guides — refer to page 36 for Valve details.

### Guides

Guides must be replaced if worn sufficiently to allow valve stem-guide clearance to exceed limits stated in the Wear Tolerance Chart on page 36. To remove, press down into valve chamber and carefully break protruding end until guide is completely removed — be careful not to damage block when removing old guide. Use an arbor press to install new guides — press to

depth specified then use a valve guide reamer and ream new guide to specified I.D. — refer to page 36 for valve guide details.

### Valves and Valve Seats

Consult parts manual for correct valve numbers when replacing valves. Some applications require special hard faced valves for both intake and exhaust valves. Exhaust valves are always hard faced. Intake valve seats are usually machined into block although inserts are used in certain applications. Exhaust valves seat on special hardened inserts. Seating surfaces should be held as close as possible to 1/32" width. Seats with more than 1/16" must be reconditioned with 45° and 15° cutters to obtain proper width. Reground or new valve must be lapped in to provide proper fit. Use a hand valve grinder with suction cup for final lapping. Lightly coat valve face with "fine" grade of grinding compound then rotate valve on seat with grinder. Continue grinding until smooth surface is obtained on seat and on valve face.

### Valve Clearance

Valve clearance must be checked after resurfacing and lapping in. Install valves in guides, rotate camshaft to position where cam has no effect on tappet — hold valve firmly on seat and check clearance between valve stem and tappet (See Clearance Section).

Adjustable tappets are used on the K241 and K301 engines. Loosen the locking nut, turn adjusting nut in or out until proper clearance is attained then securely tighten locknut.

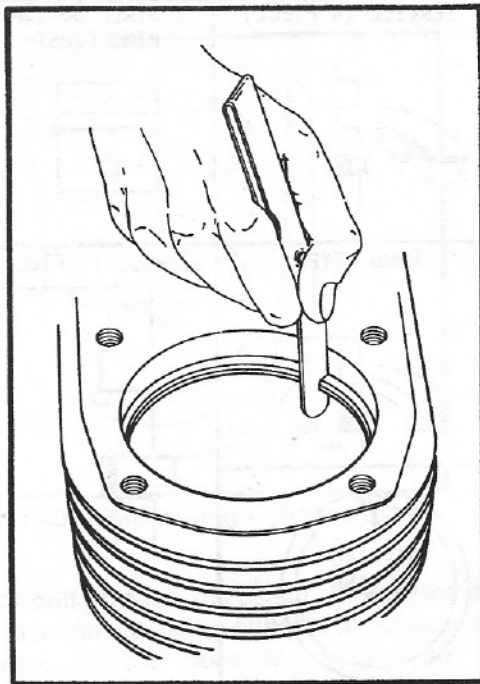

Figure 43 — Measuring Piston Ring End Gap

## CYLINDER HEAD

Blocked cooling fins often cause localized "hot spots" which can result in "blown" cylinder head gaskets. If gasket fails in area surrounding one of the retaining capscrews, high temperature combustion bases can burn away portions of aluminum alloy head. If no evidence of this is found, head should be checked for flatness. A slightly warped head can be resurfaced by simply rubbing it on a piece of sandpaper positioned on a flat surface. Carefully clean carbon deposits from cylinder head if it is to be reused — use putty knife or

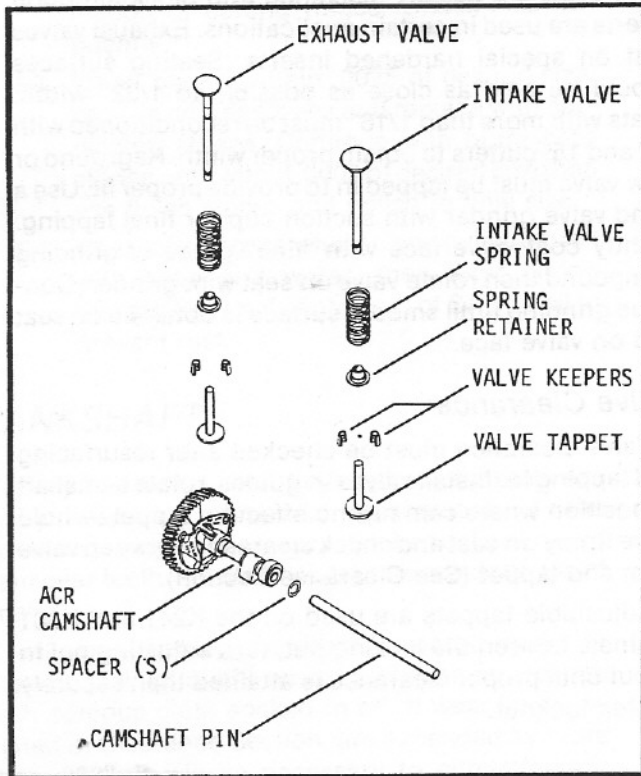

Figure 45 — Camshaft and Valve Mechanism

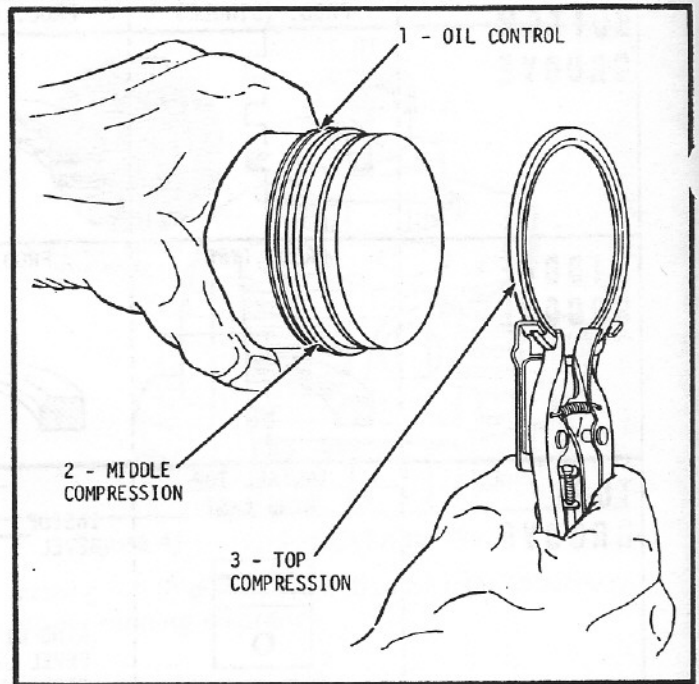

Figure 44 — Ring Installation Sequence

similar blade to scrape deposits. Be careful not to nick or scratch aluminum, especially in gasket seat area.

## RING GEAR

If inspection of the ring gear reveals broken, excessively worn or otherwise damaged teeth, the ring gear must be replaced. The ring gear is press fitted into a recess on the outer perimeter of the flywheel. The flywheel must be off the engine for ring gear replacement.

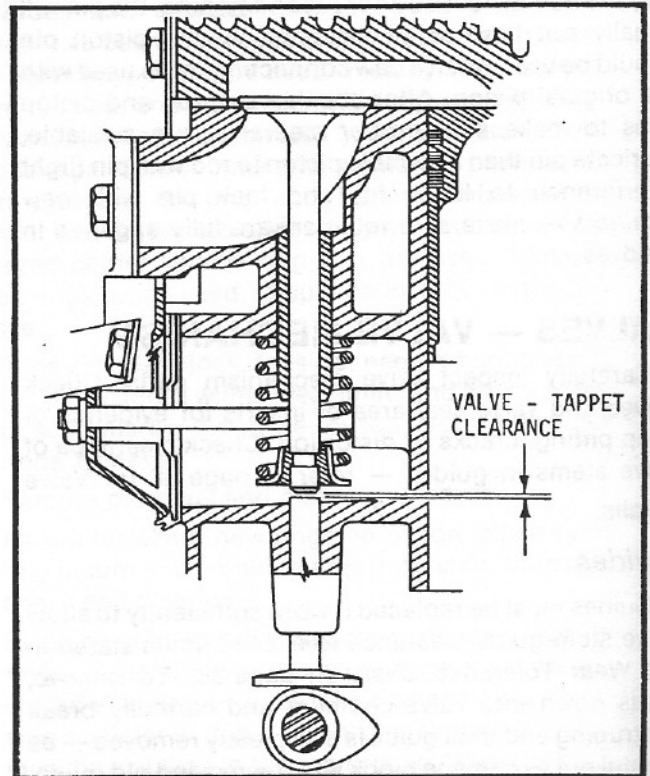

Figure 46 — Valve — Tappet Clearance

Several methods may be used to remove the damaged ring gear. One method is to break the gear with a cold chisel and/or a hack saw. Another way is to heat the ring gear with a torch, then drive the gear off the flywheel. If the latter method is used, the flywheel will also absorb some heat and it must be allowed to cool before the new ring gear can be installed.

The new gear must be expanded with heat before installation. This can be done by submerging the gear in

hot oil or heating in oven to about 400 to 450° F. Position the heated gear on the flywheel, then after making sure it is not cocked, either press the gear on with an arbor press or drive it on with a soft-head hammer. As the gear cools, it will contract to form a tight press fit on the flywheel. Be sure to tighten the flywheel retaining nut to the proper torque value after reinstalling the flywheel on the engine.

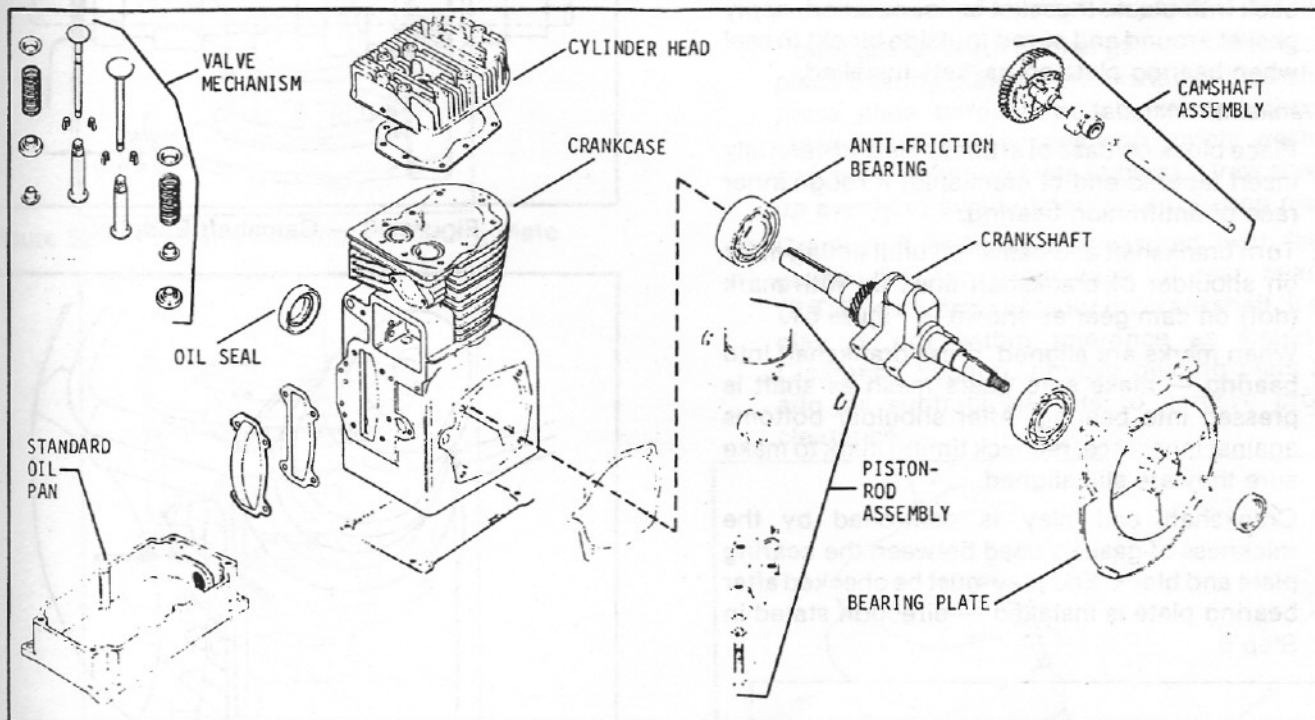

Figure 47 — Exploded View - Major Components of Typical Engine

## REASSEMBLY

### 1. Rear Main Bearing

- a. Install rear main bearing by pressing it into cylinder block with shielded side facing toward inside of block — if using unshielded type bearing, either side of face inside.

### 2. Governor Shaft

- a. Most engines have a cross shaft with an extension riveted in place to line up with governor gear. A needle bearing or bushing on later models is provided in block to hold cross shaft in alignment.

### 3. To Install Governor

- a. Place cylinder block on its side. Slide governor shaft into place from inside of block. Place speed control disc on governor bushing nut and thread bushing nut into block, clamping throttle bracket into place.
- b. The governor shaft can be adjusted for end clearance by moving needle bearing in block. Set bearing to allow a slight back-and-forth movement of the shaft.
- c. Place space washer on stub shaft and slide

governor gear assembly into place.

- d. Tighten holding screw from outside of cylinder block. Screw prevents governor gear from sliding off stub shaft during assembly.
- e. Rotate governor gear assembly to be sure holding screw does not contact weight section of gear.

### 4. Camshaft Installation

- a. Turn cylinder block upside down.
- b. Tappets must be installed before camshaft is placed. Lubricate and insert tappets in valve guides.
- c. Position camshaft inside block.
- d. Lubricate rod then insert into block (bearing plate side). Before pushing rod through camshaft, slip one .005" washer (end play) between end of camshaft (opposite gear end) and block. Push rod through camshaft and tap lightly until rod just starts into bore at P.T.O. end of block. Check end play with feeler gauge — if within tolerance press rod into final posi-

tion or remove rod and add (or subtract) .005 and .010" thick washers as necessary to attain proper end play (See Fits and Clearance Section).

- e. While rod is a tight press fit at P.T.O. end of block, a light to loose fit is necessary at the bearing plate end. New bearing plate gaskets have notch to allow any oil that may leak past to drain back into block. If gasket is not notched, apply gasket around end of rod (outside block) to seal when bearing plate and gaskets installed.

5. Crankshaft Installation

- a. Place block on base of arbor press and carefully insert tapered end of crankshaft through inner race of antifriction bearing.
- b. Turn crankshaft and camshaft until timing mark on shoulder of crankshaft lines up with mark (dot) on cam gear as shown in Figure 51.
- c. When marks are aligned, press crankshaft into bearing — make sure gears mesh as shaft is pressed into bearing. After shoulder bottoms against inner race, recheck timing mark to make sure they are still aligned.
- d. Crankshaft end play is controlled by the thickness of gaskets used between the bearing plate and block. End play must be checked after bearing plate is installed — direction stated in Step 6.

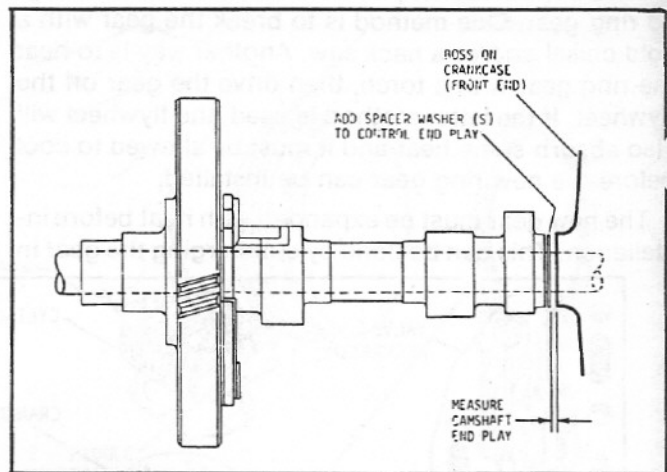

Figure 50 — Camshaft Endplay

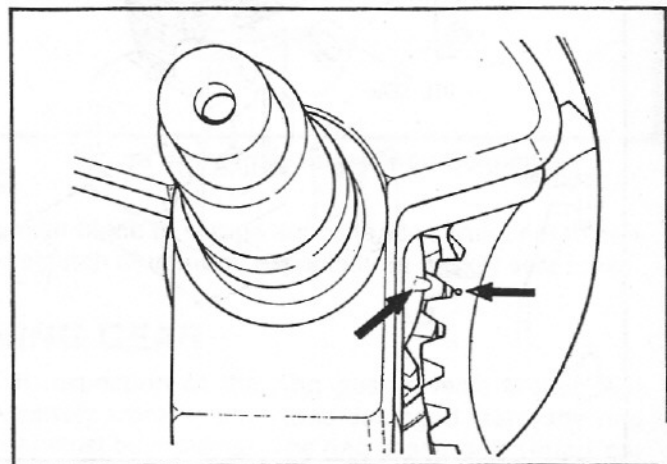

Figure 51 — Timing Marks on Crankshaft and Camshaft

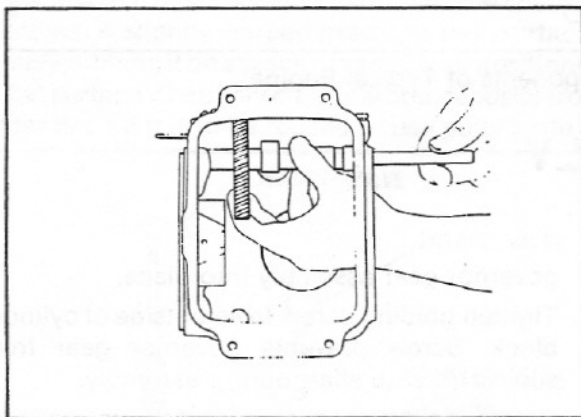

Figure 48 — Installing Camshaft

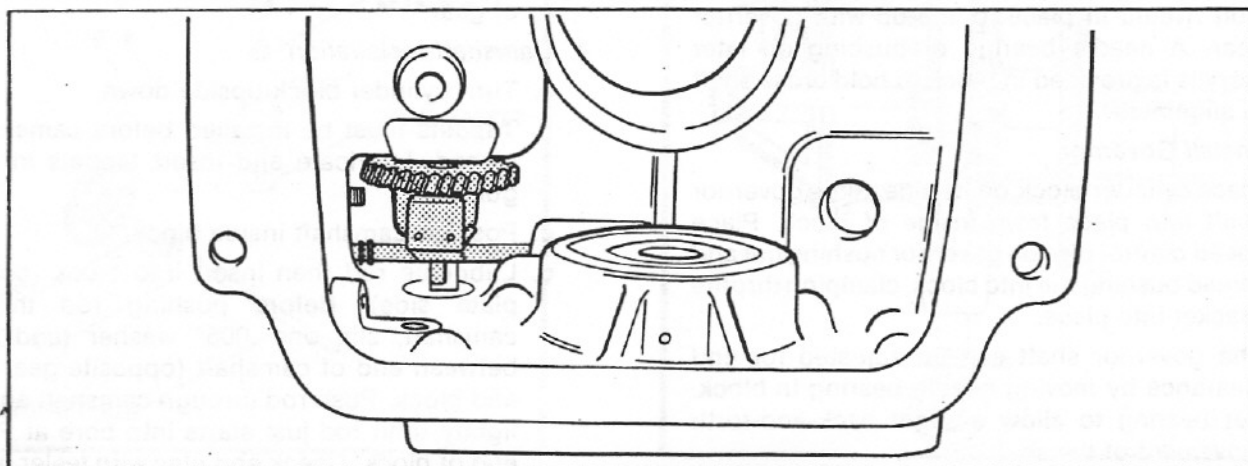

Figure 49 — Governor Gear Assembly in Crankcase

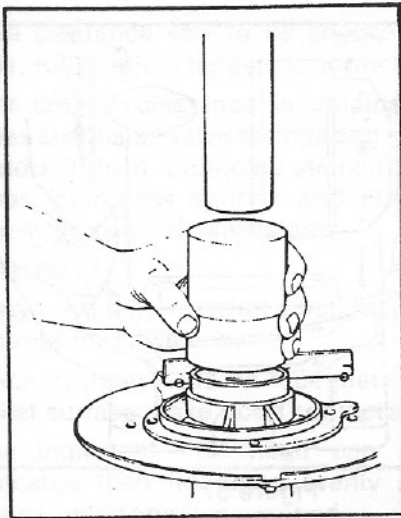

Figure 52 — Pressing Bearing in Bearing Plate

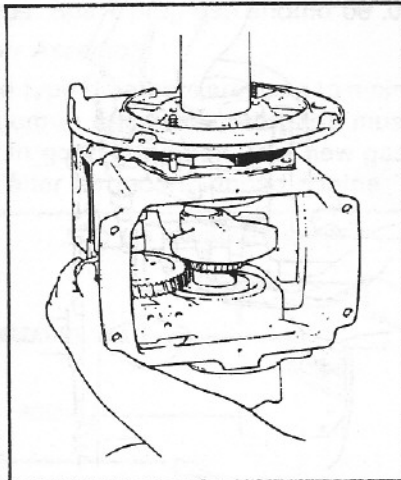

Figure 53 — Installing Bearing Plate

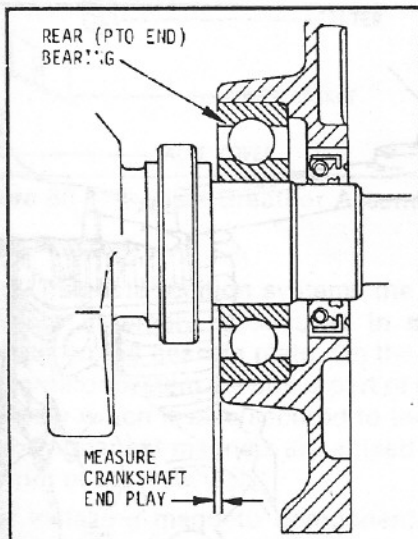

Figure 54 — Crankshaft End Clearance

## 6. Bearing Plate

- a. Press front main bearing into bearing plate. Make sure bearing is straight and true in bore and bottomed properly. If cocked, crankshaft end play will be adversely affected.
- b. Crankshaft end play is determined by thickness of gaskets used between block and bearing plate. Initial use of one .020" and one .010" gasket *should* bring end play within limits — this must be checked after bearing plate is installed.
- c. Install gaskets with thicker gasket next to block, place bearing plate on crankshaft and carefully press plate onto shaft and into position on block. Install cap screws with copper washers and secure bearing plate to block. Draw screws up evenly to avoid distortion of bearing plate.
- d. Crankshaft end play is measured (with feeler gauge between inner race of rear bearing (P.T.O. end) and shoulder on crankshaft. If end play is not within tolerance as stated in Clearance Section, remove bearing plate and add or subtract gaskets to achieve proper clearance.

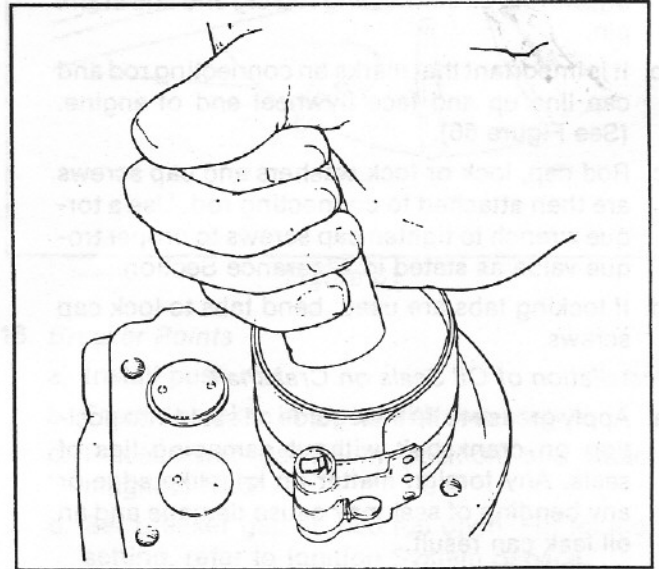

Figure 55 — Installing Piston-ring Assembly

## 7. Piston and Rod Assembly

- a. Lubricate pin then assemble piston to connecting rod and secure piston pin with retainer rings. Always use new retainer rings. Be sure retainer rings are fully engaged in grooves in piston bosses.
- b. After making sure rings are in proper position in correct grooves, oil complete assembly, stagger rings gaps so they are not in line and insert complete assembly into cylinder bore. Be sure connecting rod marking is toward flywheel side of engine. Use a ring compressor to prevent ring breakage during installation. Gently push piston into bore with hammer handle — *do not pound*.



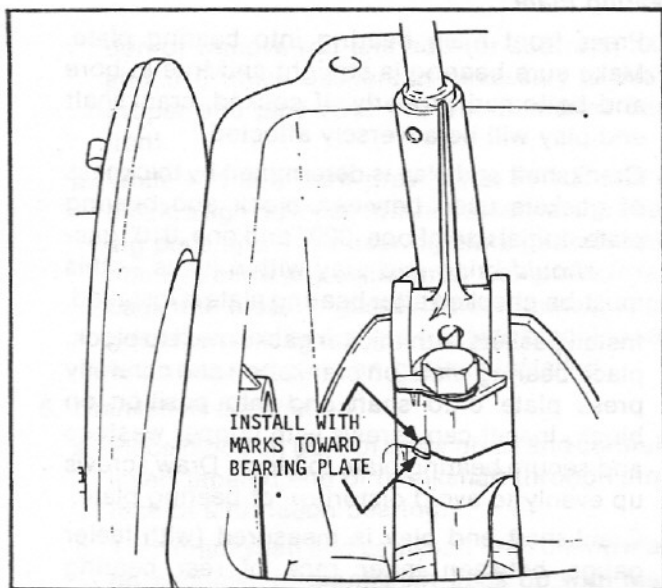

Figure 56

### 8. Attaching Rod to Crankshaft

- a. After piston assembly is installed, place block on end and oil connecting rod big end and crank pin.
- b. It is important that marks on connecting rod and cap line up and face flywheel end of engine. (See Figure 56).
- c. Rod cap, lock or lock washers and cap screws are then attached to connecting rod. Use a torque wrench to tighten cap screws to proper torque value as stated in Clearance Section.
- d. If locking tabs are used, bend tabs to lock cap screws.

### 9. Installation of Oil Seals on Crankshaft

- a. Apply grease to lip then guide oil seals into position on crankshaft without damaging lips of seals. Any foreign matter on knifelike edge or any bending of seal may cause damage and an oil leak can result.
- b. After oil seals are started on shaft, place block on its side. The oil seals may now be driven squarely into bearing plate and cylinder block.

### 10. Oil Base

- a. Use pilot studs to align cylinder block, gasket and oil base.
- b. A new gasket must be used to prevent oil leakage.
- c. Assemble oil base to block with four screws.
- d. Torque pan bolts.

### 11. Installing and Setting Valves

- a. Valves, valve seats and ports should be thoroughly cleaned. Valves should be ground and lapped-in to obtain a good valve seat. Keep valve seat from 1/32" to 1/16" in width.

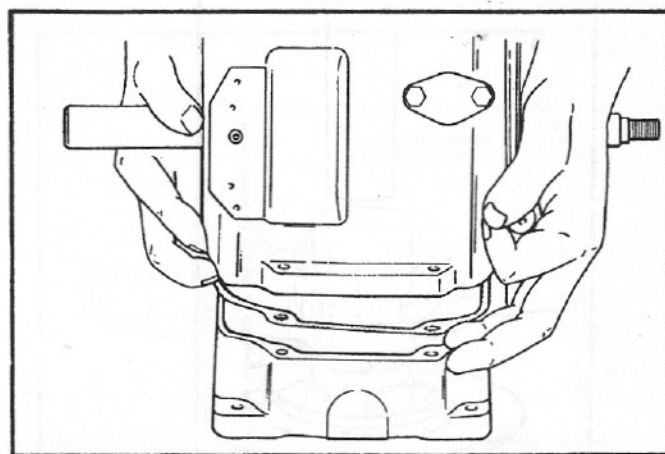

Figure 57

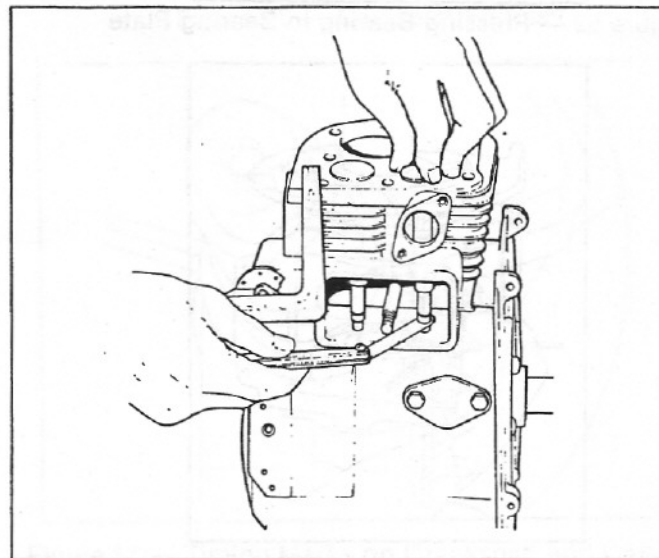

Figure 58 — Checking Valve Tappett Clearance

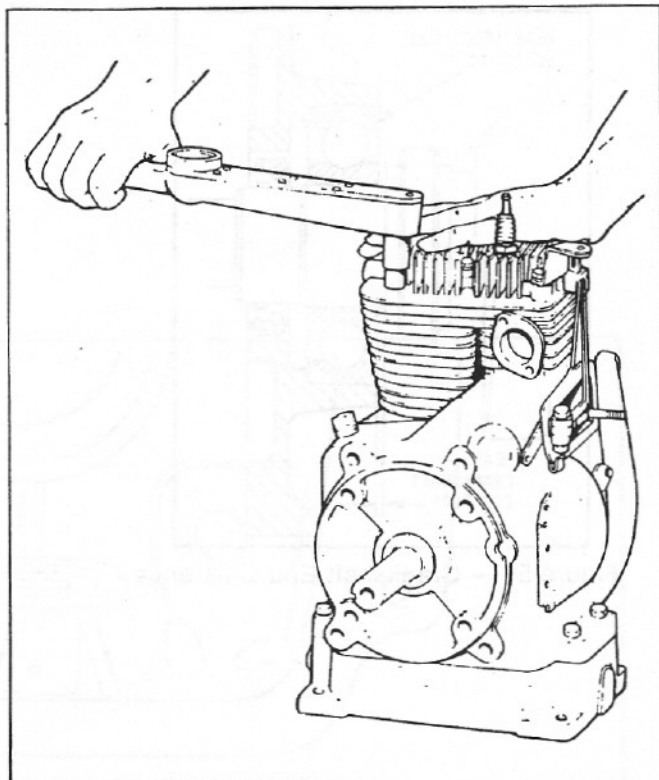

Figure 59 — Tightening Cylinder Head Capscrews

- b. Valve clearance should be checked cold. On K241, K301 adjust tappets to correct clearance.
- c. After correct clearance is obtained, remove valves and install valve springs and retainer and rotators if used. Lubricate stems then replace valves, compress springs and place locking keys in grooves of valve stems.

#### 12. Cylinder Head

- a. Always use a new gasket when head has been removed for service work.
- b. Check cylinder head on face plate to be sure gasket surface make good contact at all points. It is important that head cap screws be lubricated then tightened evenly and in sequence until torque is reached.
- d. Install new spark plug and tighten to specified torque. Spark plug gap should be .025.

#### 13. Breather Assembly

Reed type breathers are used to maintain slight vacuum in crankcase. All parts must be clean and in good condition. Use new gaskets, reed and filter for reconditioned engine.

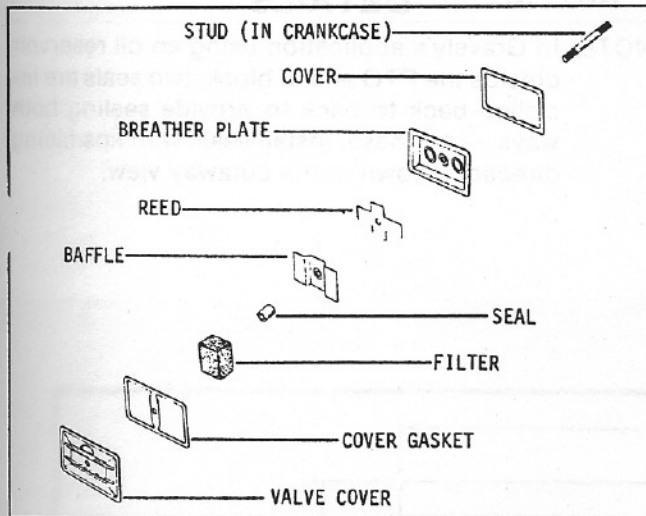

Figure 60 — Typical Breather Assembly

#### 14. Magneto

- a. On all magneto ignition systems the magneto coil-core assembly is secured in stationary position on the bearing plate. On the magneto — alternator system the coil is part of the stator assembly which is also secured to the bearing plate. Permanent magnets are affixed to the inside rim of the flywheel.
- b. After installing magneto components, run all leads out through hole provided (in 11 o'clock position) on bearing plate.

#### 15. Flywheel

- a. Place wave washer on crankshaft and place flywheel in position. The square key holds flywheel on shaft.
- b. Install starter pulley, lock washer and holding

nut. Insert a bar between flywheel fins and tighten holding nut to torque value specified in Clearance Section.

- c. The rotating screen is fastened to starter pulley with screws and spacers.

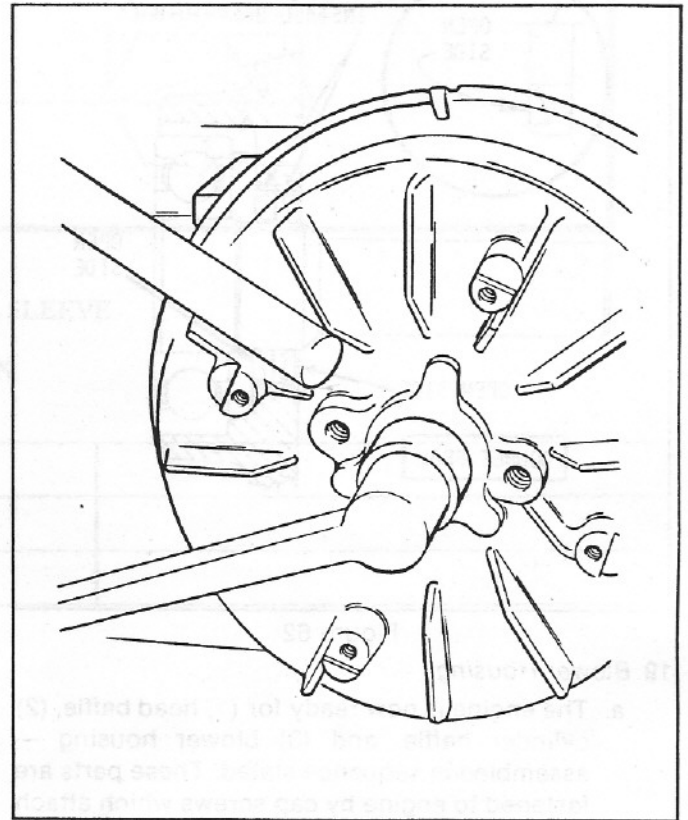

Figure 61

#### 16. Breaker Points

- a. Install push rod.
- b. Fasten breaker in place with two screws.
- c. Place cover gasket in position and attach magneto lead.
- d. Set breaker gap at .020 full open. For ignition setting, refer to Ignition System Service.
- e. Make preliminary adjustments before installing breaker point cover. Be sure breaker lead grommet is in place.

#### 17. Carburetor

- a. Insert a new gasket and assemble carburetor to intake port with two screws.
- b. Refer to Service Section on carburetor adjustment procedure.

#### 18. Governor Arm and Linkage

- a. Insert carburetor linkage in throttle arm.
- b. Connect governor arm to carburetor linkage and slide governor arm onto governor shaft.
- c. Before tightening clamp bolt, turn shaft counter clockwise as far as possible with a pair of pliers, pull arm as far as possible to left (away from carburetor), tighten nut and check for freedom of movement.

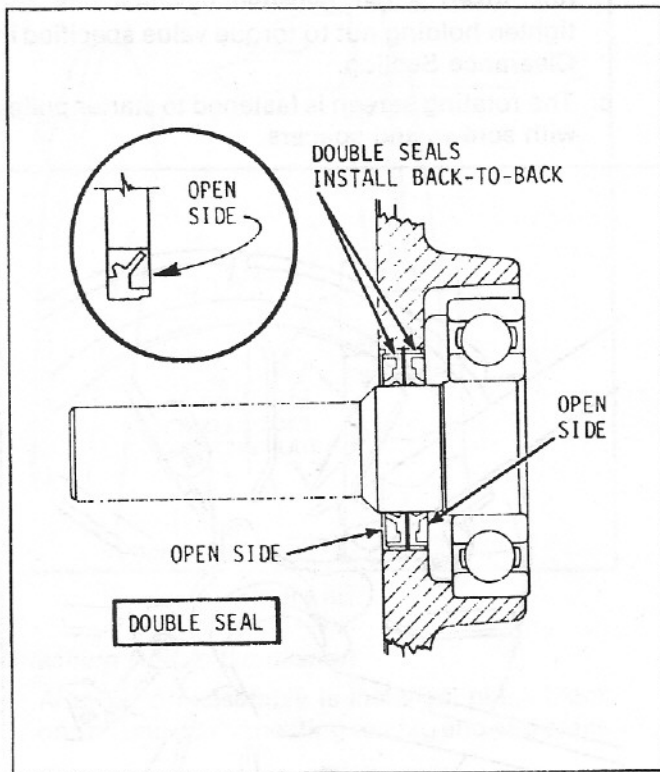

Figure 62

#### 19 Blower Housing

- a. The engine is now ready for (1) head baffle, (2) cylinder baffle, and (3) blower housing — assembled in sequence stated. These parts are fastened to engine by cap screws which attach to cylinder head and bearing plate. Caution:

Shorter screws go into lower portion of blower housing.

- b. Connect fuel line between pump and carburetor.

#### Final Adjustments

Follow instructions in Service Procedure Section for final adjustment of engine.

#### Run-In Procedures (Reconditioned Engines)

After an engine has been reconditioned and reassembled, it must be "run-in" on *non-detergent* oil and *under load* for a period of about 5 hours. This should be sufficient time to seat the piston rings.

After the initial run-in period, drain the non-detergent type oil and refill with *detergent type API Service SC* oil of proper weight. (See Page 4.) *Do not continue* using non-detergent oil after the first 5 hours of operation.

#### REAR OIL SEAL INSTALLATION DETAILS

**NOTE:** In Gravely's application using an oil reservoir outside the PTO end of block, two seals are installed back to back to provide sealing both ways — on these, install seals with lips facing direction shown in the cutaway view.

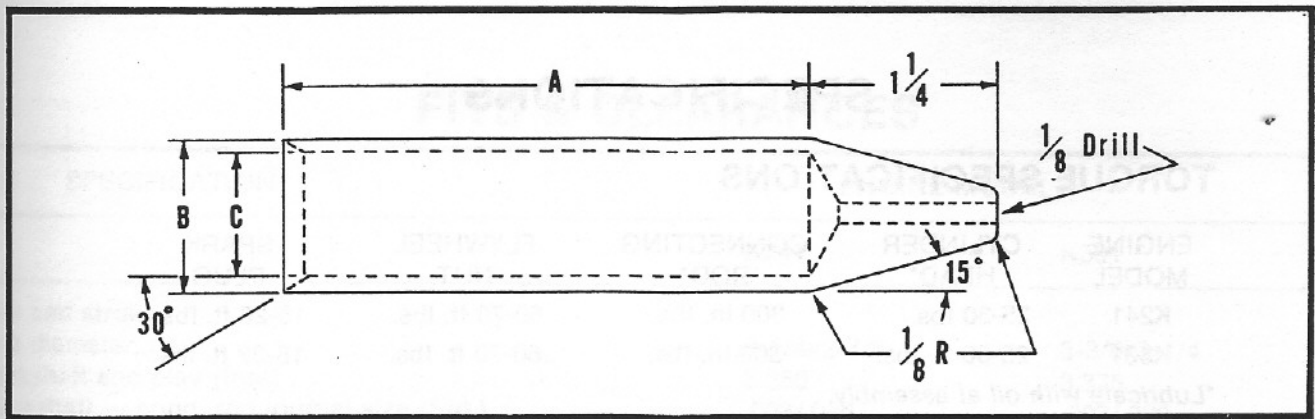

DIMENSIONAL DIAGRAM – SEAL SLEEVE

SEAL SLEEVE DIMENSION

K241, K301

A	7-5/16"	
B	1.245/1.250"	
C	1.002/1.003"	

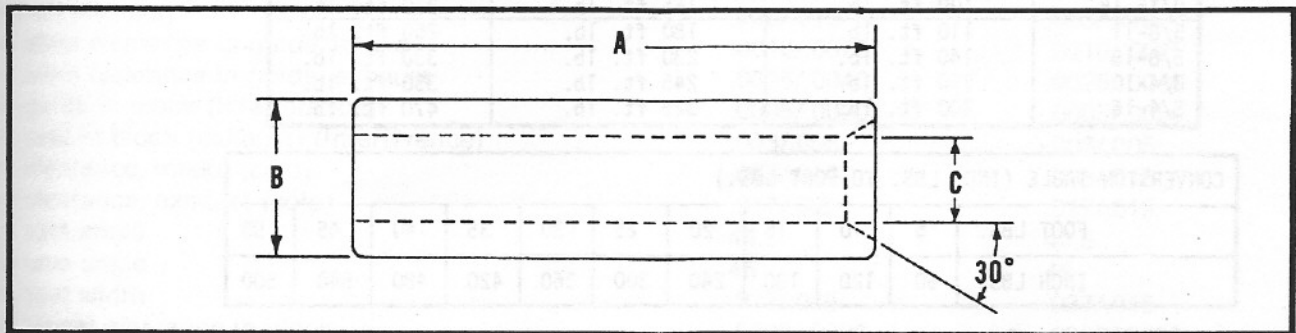

DIMENSIONAL DIAGRAM – SEAL DRIVER

SEAL DRIVER DIMENSION

K241, K301

A	8-13/16"	
B	1-11/16"	
C	1.248/1.253"	



# SPECIFICATIONS

## TORQUE SPECIFICATIONS

ENGINE MODEL	CYLINDER HEAD*	CONNECTING ROD*	FLYWHEEL NUT	SPARK PLUG
K241	25-30 lbs.	300 in. lbs.	60-70 ft. lbs.	18-22 ft. lbs.
K301	25-30 ft. lbs.	300 in. lbs.	60-70 ft. lbs.	18-22 ft. lbs.

\*Lubricate with oil at assembly.

## STANDARD BOLTS, SCREWS & NUTS

Size	Tightening Torque		
	Grade 2 	Grade 5 	Grade 8 
1/4-20	70 in. lb.	115 in. lb.	165 in. lb.
1/4-28	85 in. lb.	140 in. lb.	200 in. lb.
5/16-18	150 in. lb.	250 in. lb.	350 in. lb.
5/16-24	165 in. lb.	270 in. lb.	30 ft. lb.
3/8-16	260 in. lb.	35 ft. lb.	50 ft. lb.
3/8-24	300 in. lb.	40 ft. lb.	60 ft. lb.
7/16-14	35 ft. lb.	55 ft. lb.	80 ft. lb.
7/16-20	45 ft. lb.	75 ft. lb.	105 ft. lb.
1/2-13	50 ft. lb.	80 ft. lb.	115 ft. lb.
1/2-20	70 ft. lb.	105 ft. lb.	165 ft. lb.
9/16-12	75 ft. lb.	125 ft. lb.	175 ft. lb.
9/16-18	100 ft. lb.	165 ft. lb.	230 ft. lb.
5/8-11	110 ft. lb.	180 ft. lb.	260 ft. lb.
5/8-18	140 ft. lb.	230 ft. lb.	330 ft. lb.
3/4-10	150 ft. lb.	245 ft. lb.	350 ft. lb.
3/4-16	200 ft. lb.	325 ft. lb.	470 ft. lb.

FOOT LBS.	5	10	15	20	25	30	35	40	45	50
INCH LBS.	60	120	180	240	300	360	420	480	540	600

CYLINDER HEAD TIGHTENING SEQUENCE

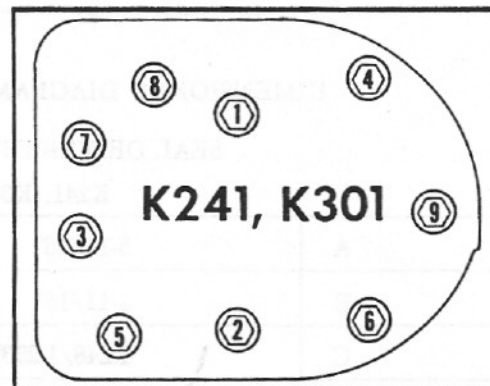

# FITS & CLEARANCES

SPECIFICATION	ENGINE MODEL	
	K241	K301
Bore and stroke		
Bore diameter, new	3-1/4x2-7/8	3-3/8x3-1/4
crankshaft end play (free)	3.250	3.375
Crankshaft — conn. rod journal size (Std.)	.003/.020	.003/.020
Crankpin — conn. rod side clearance	1.500/1.4995	1.5000/1.4995
Crankpin length	.007/.016	.007/.016
Main bearing journal diameter	1.187-1.180	
Connecting rod to crankpin running clearance	1.575	1.575
Connecting rod to piston pin clearance	.001/.002	.001/.002
Piston pin to piston boss	.0003/.0008	.0003/.0008
	.0000/.0003	One Thumb
	Select	Push
Piston to cylinder bore (thrust face)	Fit	Fit
Piston to cylinder bore (top of skirt)	.003/.004	.003/.004
Piston pin diameter (Std.)	.0075/.0085	.0065/.0095
Ring side clearance, top ring	.8592	.8753
Ring side clearance, middle ring	.002/.004	.002/.004
Ring side clearance, oil ring	.002/.004	.002/.004
Ring end gap	.001/.003	.001/.003
Ring width, top ring	.010/.020	.010/.020
Ring width, middle ring	.093	.093
Ring width, oil ring	.093	.093
	.005/.010	.005/.010
Camshaft pin to camshaft clearance	.001/.0035	.001/.0035
Camshaft pin to block (Bearing plate end)	.0005/.002	.0005/.002
Camshaft pin to block (P.T.O.E.) (Int.)	.0015/.003	.0015/.003
Camshaft pin to breaker cam	.0010/.0025	.0010/.0025
Camshaft end play	.005/.010	.005/.010
Valve stem clearance in guide, intake	.0010/.0025	.0010/.0025
Valve stem clearance in guide, exhaust	.0025/.0040	.0025/.0040
Valve guide in block (Interference)	.0005/.0020	.0005/.0020
Valve seat in block (exhaust) (Interference)	.003/.005	.003/.005
Valve clearance, intake (cold)	.008/.010	.008/.010
Valve clearance, exhaust (cold)	.017/.019	.017/.019
Valve seat angle	44.5	44.5
Valve face angle	45	45
Valve seat width	.037/.045	.037/.045
Valve tappet clearance in block	.0008/.0023	.0008/.0023
Governor bushing to gov. cross shaft clear.	.001/.0025	.0010/.0025
Governor gear to governor shaft	.0005/.0020	.0005/.0020
Governor cross shaft end play	.005/.030	.005/.030
Ball bearing to cylinder block (Inference)	.0006/.0022	.0006/.0022
Ball bearing to bearing plate (Interference)	.0012/.0028	.0012/.0028
Ball bearing to crankshaft (Int. to loose)	.0004/.0005	.0004/.0005

# TRANSMISSION TROUBLE SHOOTING

Unless internal damage is evident, check all external adjustments, and check for bent control rods before opening transmission.

1. Tractor has Forward drive, but no Reverse drive in High/Low range. Check for missing woodruff key on 18024PI clutch hub on Reverse clutch side.
2. Tractor has reverse drive, but no Forward drive in High/Low range. Check for missing woodruff key on 18024PI clutch hub on Forward clutch side.
3. Unable to shift High to Low range, or Low to High range. Check for broken roll pin, or linkage. It could also be caused by a badly burred High/Low shifting gear.
4. Hard shifting Forward to Reverse. Check for lubrication on clutch assembly. This often contributes to broken clutch support studs. Lack of lubrication on clutch rollers can also cause this problem.
5. Hard shifting in High and Low range. Check for broken shifting fork.
6. No Forward or Reverse in any gear or range. Check for sheared axle key. Check for broken axle. This is done by raising the rear wheels clear of the ground, and pull on each wheel. If axle is broken, axle will move in and out.
7. P.T.O. will not run power driven attachment. P.T.O. clutch has failed. Lining on clutch cone assembly is badly worn. This would be indicated by no free travel on P.T.O. control lever, which should be from 1-3/8" (3.5cm) to 1-1/2" (3.81 cm). Woodruff keys left out on clutch cups on P.T.O. shaft, or P.T.O. drive shaft gear. Clutch cup hanging on woodruff key near shifting yoke.
8. P.T.O. will not disengage. Check free travel of control lever. There should be 1-3/8" (3.5cm) to 1-1/2" (3.81 cm) of free travel of the control lever. Make adjustment if necessary.

If this does not eliminate the problem, the probable cause is the clutch cones sticking to the clutch lining, caused by rough or burred clutch cones. Disassemble the P.T.O. and polish the inside of the clutch cones.

9. Differential Failure. Check sliding gear shaft in Forward and Reverse. If shaft turns, the problem is inside the differential housing and will have to be disassembled. Could also be broken axle. Check P.T.O. in Forward and Reverse. If P.T.O. does not turn, the problem could be the woodruff key is sheared or missing on the engine crank shaft. Also check condition of beveled gears. Raise both rear wheels clear of the ground and rotate one wheel. The other wheel should rotate in the opposite direction; if it doesn't, the problem is either in the differential or an axle is broken. (See No. 7 above for broken axle check).
10. Oil leaks. Oil leaks generally occur from a damaged "O" ring, oil seal, gasket or improper installation of these. When these items are damaged they should be replaced with new material. Never attempt a repair of these items. When installing new "O" rings or oil seals, be extremely careful not to cut these on sharp edges, such as the shoulder on the wheel axle. When installing oil seals and gaskets, use Permatex #3.
11. If an oil leak occurs along the bottom of the transmission, and a new gasket has been installed, check the 3/8" and 1/2" plugs at the four speed shifting fork area. (See Illustrated Parts List). If either of these plugs leak oil they will have to be replaced. Use "Locktite" when replacing these plugs.

NOTE: When ordering a new transmission housing, these plugs will have to be ordered separately. They are not installed in the replacement housing.

# TRANSMISSION

The wheel makes an excellent stand. However a spacer must be placed on the left axle between the bearing retainer and wheel hub. A spacer can easily be made using a piece of 1¼ inch (3.2 mm) pipe, 1½ (3.8 cm) to 2 inches (5.1 mm) long. Remove burrs from edges of pipe.

Raise the left wheel and remove wheel, hub, axle key. Place spacer on axle. Reinstall wheel and hub.

## REMOVAL:

Note: Remove engine as covered on page 6.

1. Remove hydraulic lines from the pump and drain hydraulic reservoir, if so equipped.
2. Remove the forward clutch rod from the right clutch cam.
3. Remove the reverse clutch rod from the left clutch cam.
4. Remove the two speed rod from the shifter arm.
5. Remove the shifting rods from the 1-3 and 2-4 shifter arms.
6. Remove the PTO rod from the PTO lever.
7. Remove the lift rod from the cross shaft weldment.
8. Remove the brake rod from the brake band assembly.
9. Remove the bolts securing the cross shaft weldment to the transmission case.

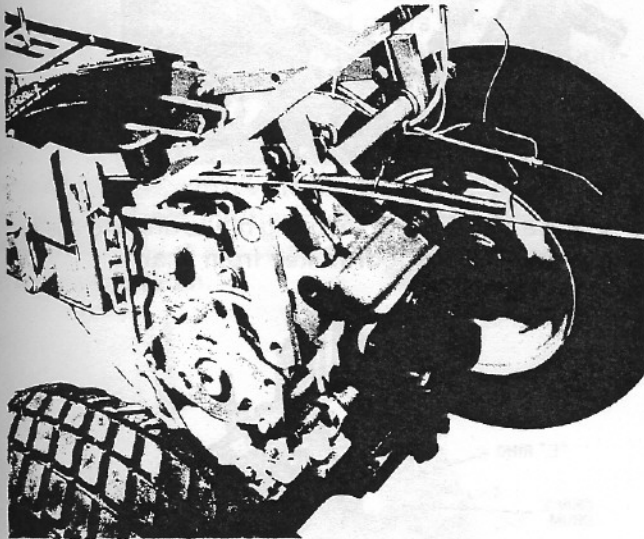

10. Raise the crossshaft weldment up to clear the transmission case.
11. Block tires from rolling and support transmission case in front of wheels.
12. Remove the bolts and nuts securing the transmission case to the frame.
13. Lift and roll frame forward and out of the way.

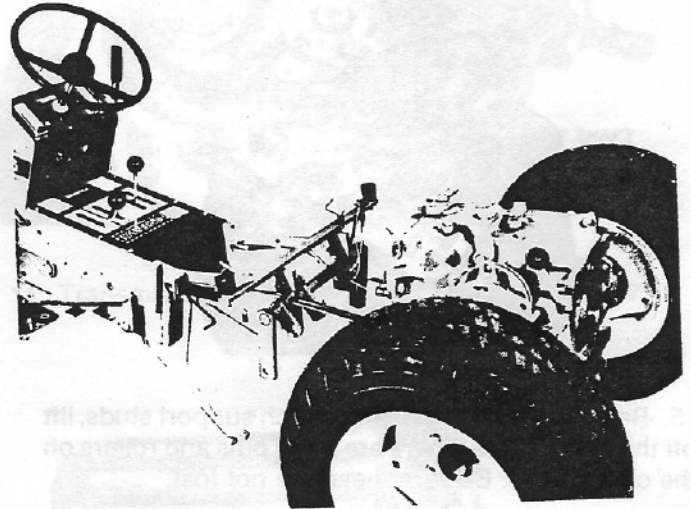

## DISASSEMBLY

1. When the transmission has been disconnected and clear of frame, turn the transmission up on the left wheel.
2. Remove right wheel from hub.
3. Remove the "E" ring securing the wheel hub to the axle. Lift hub and woodruff key from the axle.

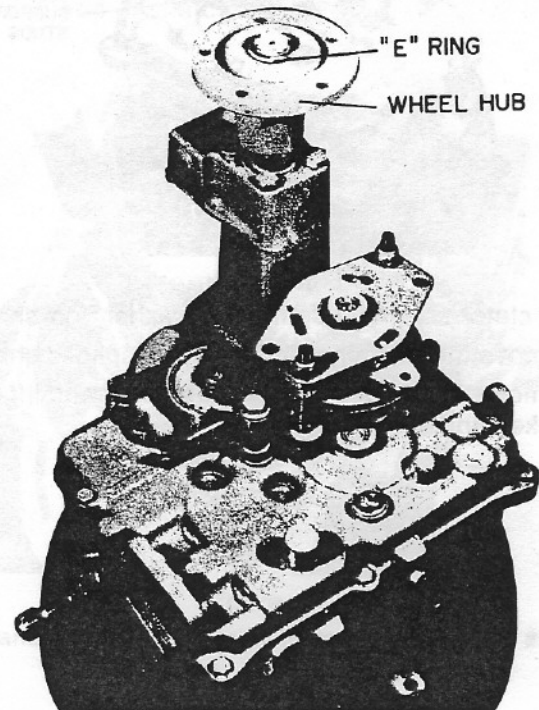

Figure 1



4. Remove the four bolts securing the axle bearing retainer and lift retainer from axle.

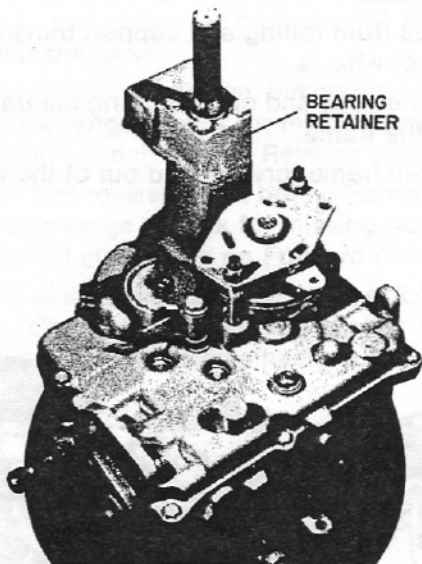

Figure 2

5. Remove the nuts from the clutch support studs, lift off the clutch plate. There are three pins and rollers on the clutch plate. Be sure these are not lost.

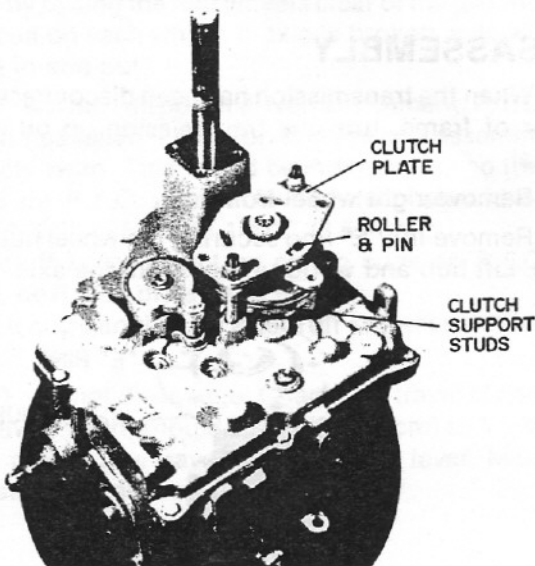

Figure 3

6. Lift clutch assembly, spring and washer from shaft.
7. Remove the retaining ring from the splined shaft.
8. Remove the brake band mounting bolt, and lift off brake band.

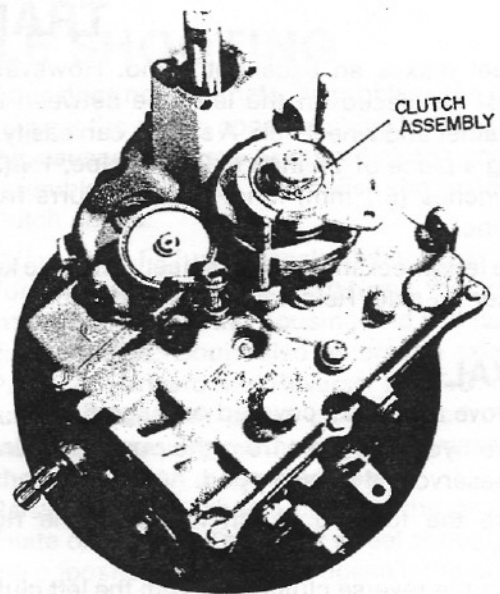

Figure 4

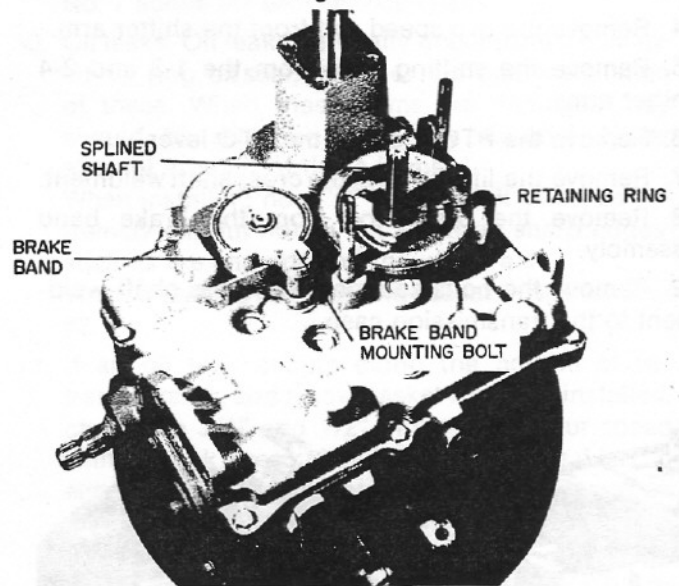

Figure 5

9. Remove the "E" ring securing brake drum to shaft. Remove drum and woodruff key from shaft.

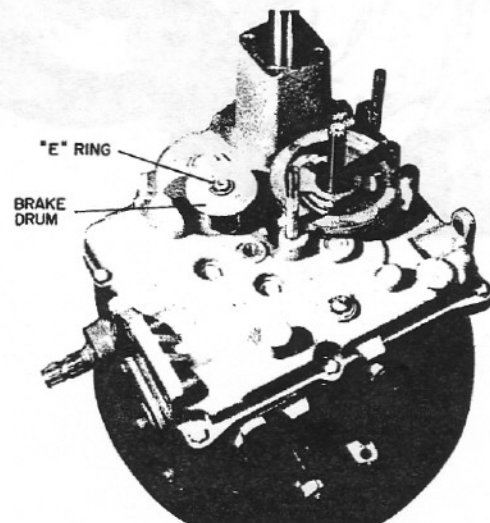

Figure 6

10. Remove the "E" ring shown in fig. 7. Remove the bolts securing the transmission cover to transmission case and lift the cover from the case. If difficulty is experienced in removing the cover, tap the protruding nafts with a soft hammer.

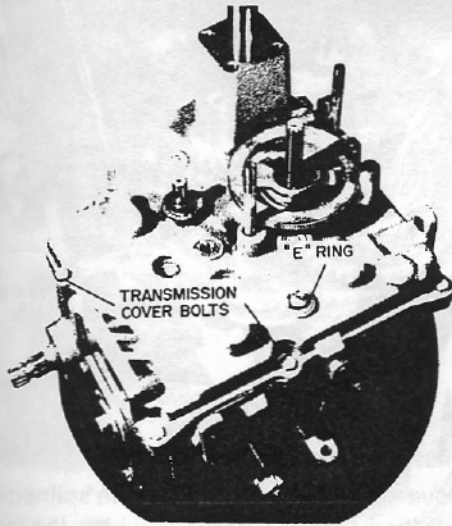

Figure 7

11. When cover is removed, carefully examine the transmission for damage or abnormalities. When removing the shafts, examine the splined shafts for burring and chipped or broken gears. Shifting ranges with the tractor in motion will cause the gears to burr and not mesh. If this happens the tractor will have no power in forward, but power in reverse.

12. When removing the gear assemblies, it is good practice to keep the gears, shaft, race and bearings on the shaft being removed where possible. When removing the shafts note the beveled gears. (Bevel meshes with bevel.) Carefully examine the assembly for burring, chipped gears, worn bearings and race.

13. Note figure 8. The shafts are numbered for identification *only*. The shafts are pictured and described in removal sequence to give the least amount of difficulty in removing from the transmission case. The shafts may be removed in any sequence as required for repair of the transmission.

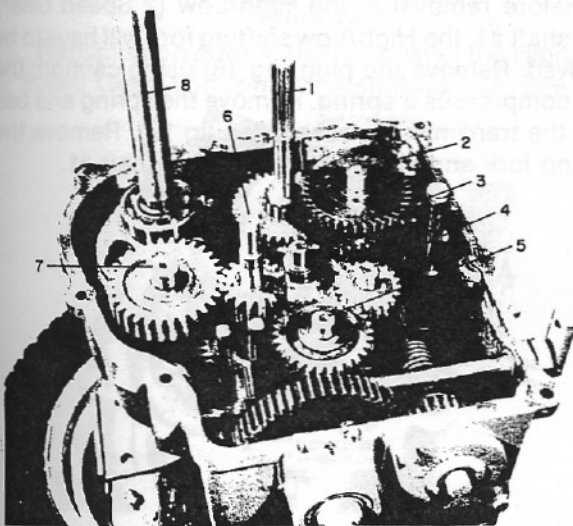

Figure 8

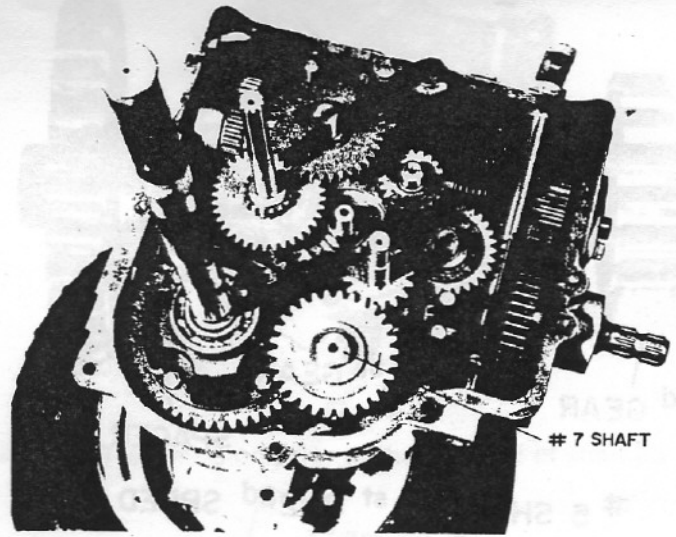
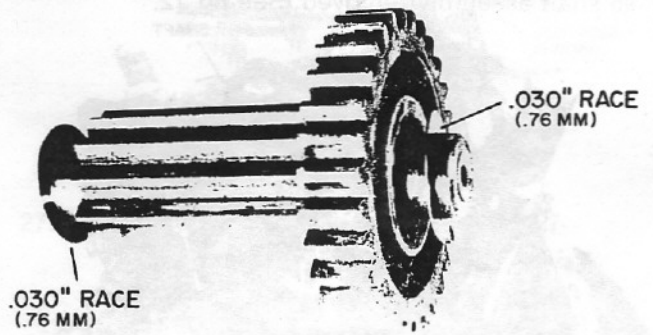

Figure 9

14. Transmission case prior to removal of shaft #7.



# 7 SHAFT - PINION & FINAL DRIVE

Figure 10

15. #7 shaft assembly removed. A .030" (.76 mm) race is on each end of shaft. See fig 10.

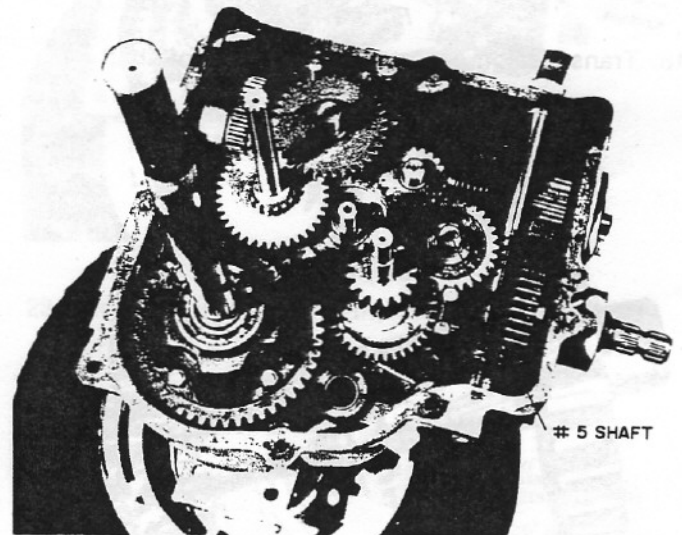

Figure 11

16. Transmission case prior to removal of shaft #5.

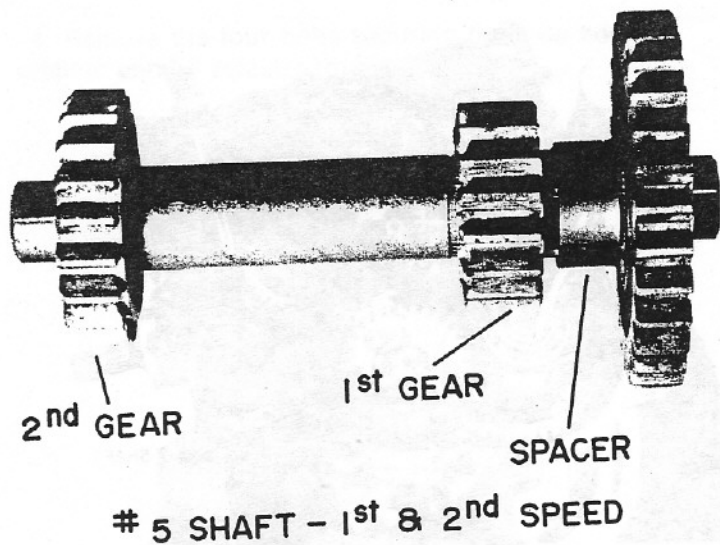

Figure 12

17 #5 shaft assembly removed. See fig 12.

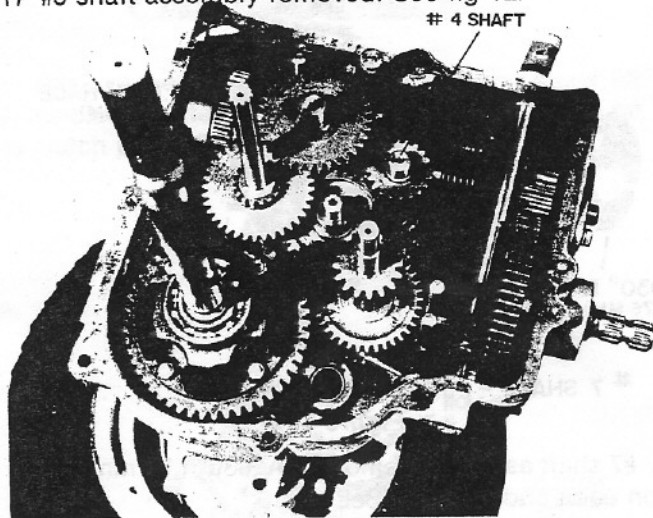

Figure 13

18. Transmission case prior to removal of shaft #4.

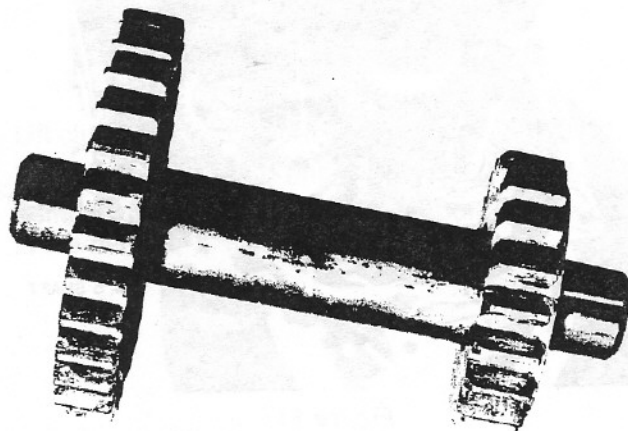

Figure 14

19. #4 shaft assembly removed. See fig 14.

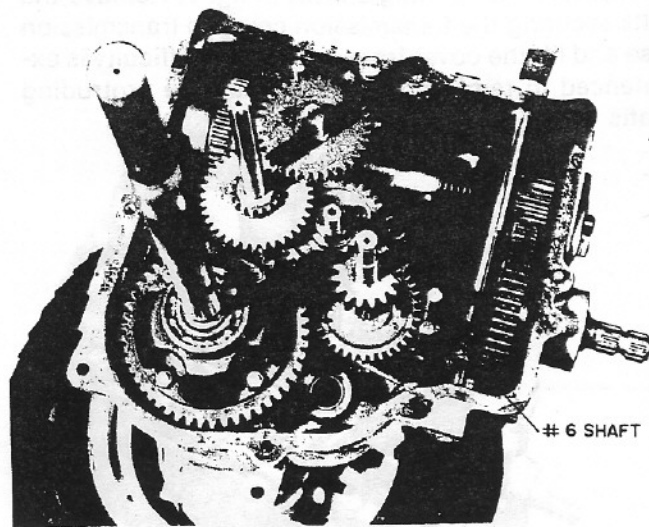
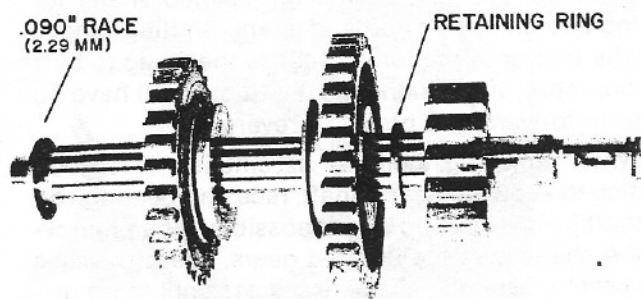

Figure 15

20. Transmission case prior to removal of shaft #6.

21. To remove shaft #6, first remove the splined shaft. Swing the shifting fork to a position where the remaining gears can be removed. Place these back on the shaft in order. There is a .090" (2.29 mm) race against the transmission case. Put this on the shaft.



# 6 SHAFT - BRAKE & SLIDING GEARS

Figure 16

22. #6 shaft assembly removed. See fig 16.

23. Transmission case prior to the removal of the High/Low (2 Speed Gear) from shaft #1, and the Idler Gear from shaft #2.

24. Before removal of the High/Low (2 Speed Gear) from shaft #1, the High/Low shifting fork will have to be removed. Remove the plug (fig 18) using caution; the plug compresses a spring. Remove the spring and ball from the transmission case. (See fig 19). Remove the shifting fork and High/Low gear from shaft #1.

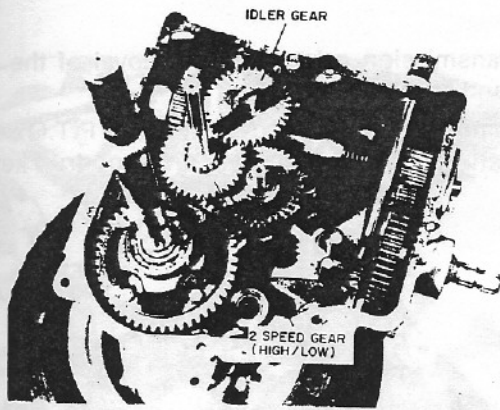

Figure 17

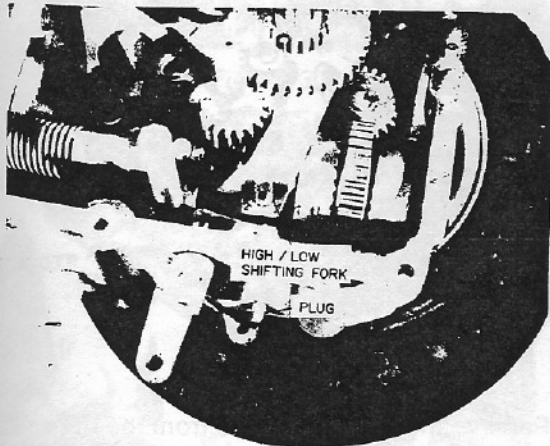

Figure 18

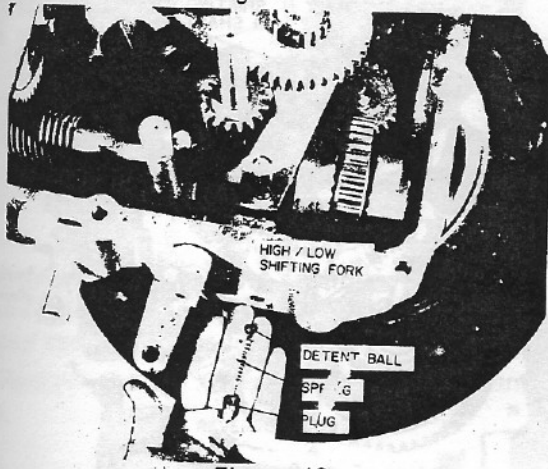

Figure 19

25. Transmission prior to the removal of the High/Low (2 Speed Gear) and High/Low shifting fork. See fig. 20.

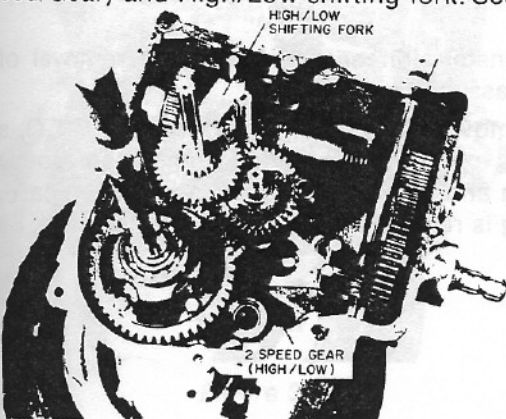

Figure 20

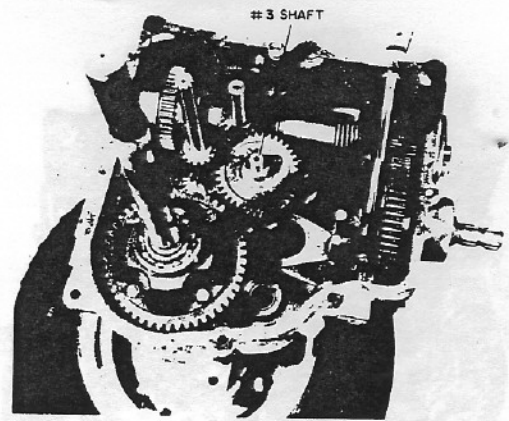
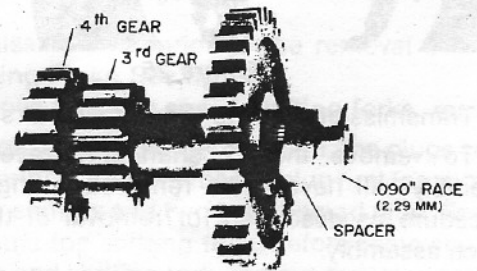

Figure 21

26. Transmission prior to the removal of shaft #3.



# 3 SHAFT - 3<sup>rd</sup> & 4<sup>th</sup> SPEED

Figure 22

27. #3 shaft assembly removed. See fig 22.

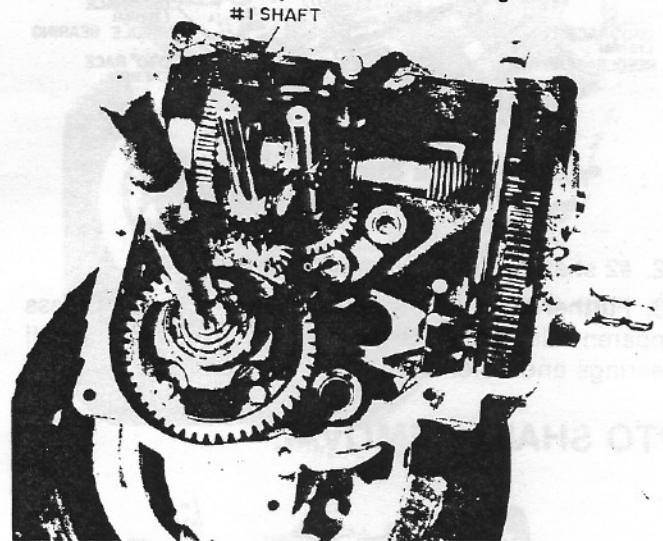
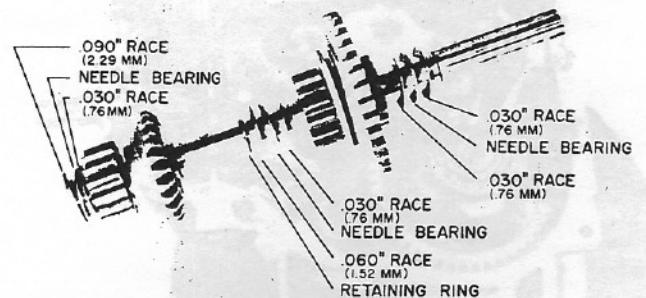

Figure 23

28. Transmission prior to the removal of shaft #1.



# 1 SHAFT - FORWARD CLUTCH

Figure 24

29. #1 shaft assembly removed. See fig 24.

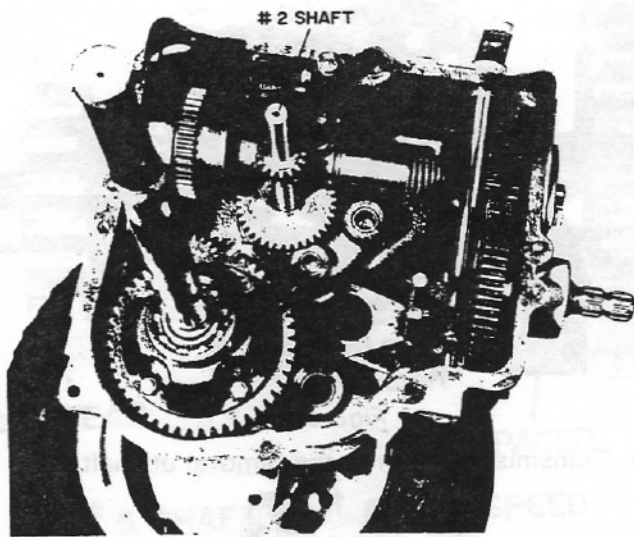
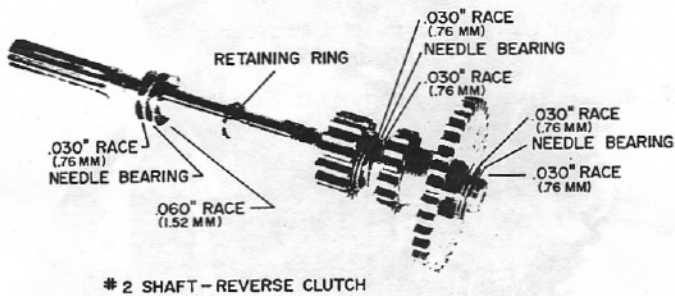

Figure 25

30. Transmission prior to the removal of shaft #2.

31. To remove the #2 shaft, the reverse clutch assembly will have to be removed, using the same procedure as described for removal of the forward clutch assembly.



# 2 SHAFT - REVERSE CLUTCH

Figure 26

32. #2 shaft assembly removed. See fig 26.

33. Further disassembly is usually unnecessary unless apparent damage is evident. Carefully examine all bearings and other components for damage.

## PTO SHAFT REMOVAL

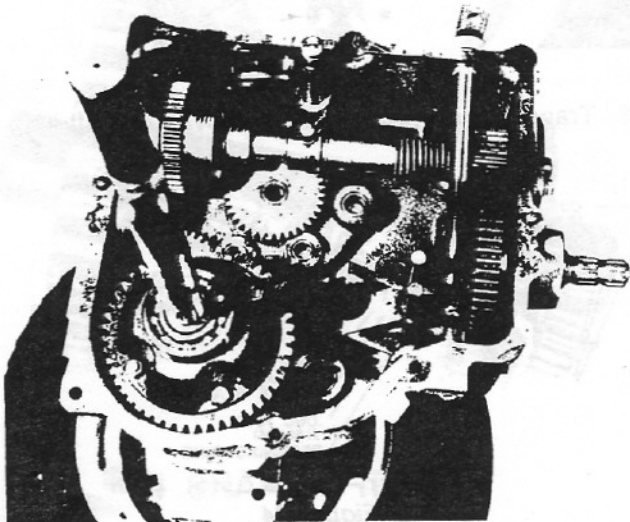

Figure 27

34. Transmission prior to the removal of the P.T.O. shaft and shifting yoke.

35. Remove the "E" ring securing the P.T.O. lever to the shaft. Remove P.T.O. lever and woodruff key from shaft.

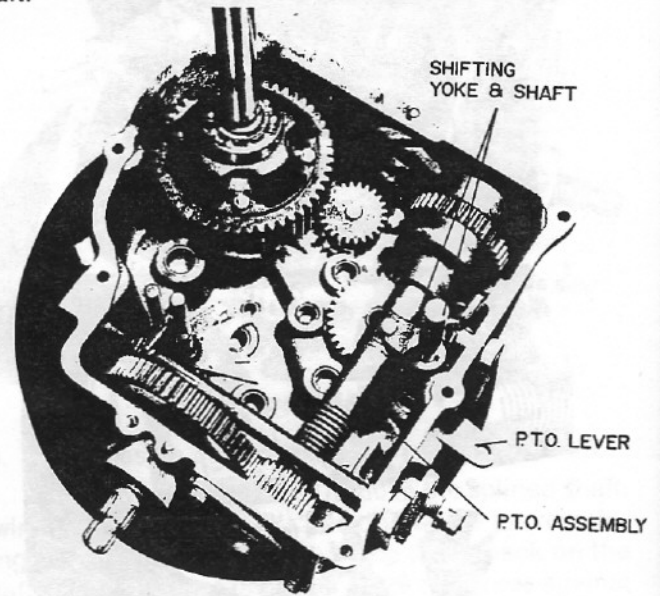

Figure 28

36. Remove the shaft and yoke from the transmission case.

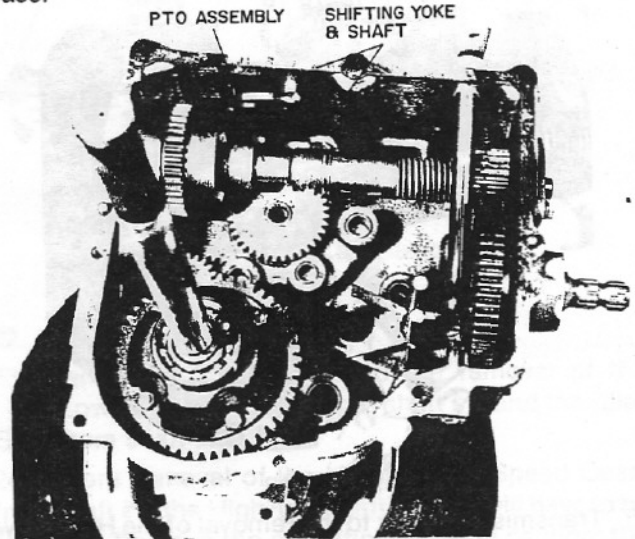

Figure 29

37. Transmission case prior to the removal of the P.T.O. assembly.

38. Remove the retaining ring from the P.T.O. shaft. Using a punch and hammer, gently tap around the bearing and remove from the transmission case. The bearing is removed to the outside of the case. See fig 30.

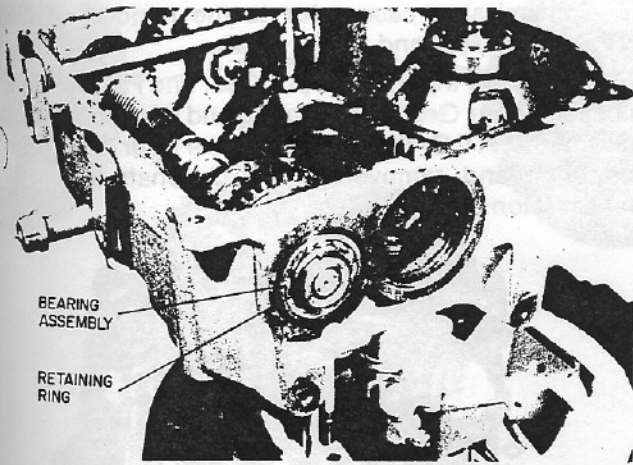

Figure 30

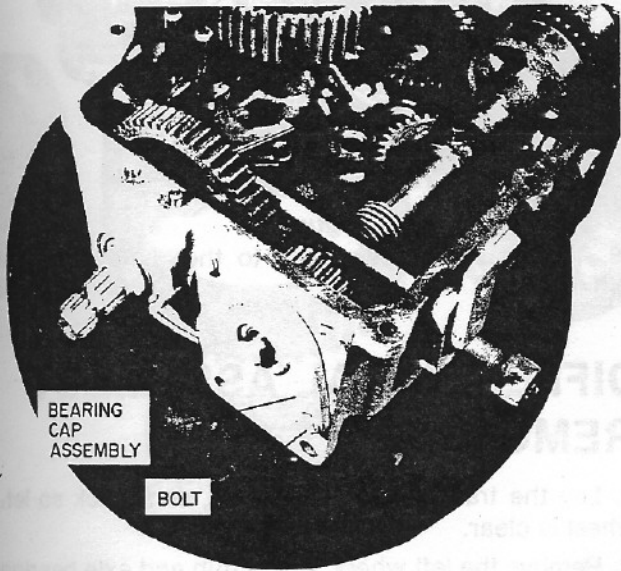

Figure 31

39. Remove the two bolts securing the bearing cap assembly to the transmission case. Remove the bearing cap assembly. See fig 31.

40. Remove the P.T.O. assembly from transmission case.

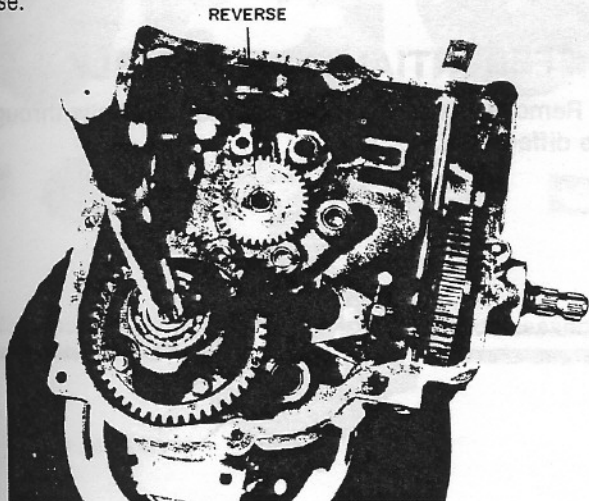

Figure 32

41. Transmission case prior to the removal of the Reverse Gear.

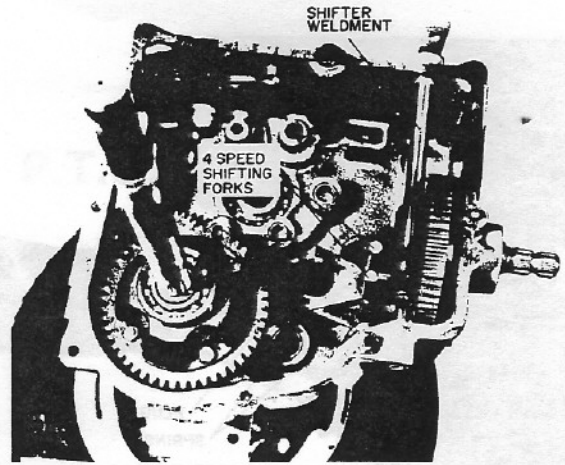

Figure 33

42. Transmission case prior to the removal of the 4 speed Shifting Forks. See fig. 33.

43. To remove the four speed shifting forks, remove the two plugs. See fig 34. Use caution, the plugs compress two springs. Remove the top plug first (as shown) and the two springs and two balls behind plug. See fig 35. Lift out the top shifting fork. Before removing the bottom plug and shifting fork, remove the interlock pin from the transmission case located between the two shifting forks. See fig 36.

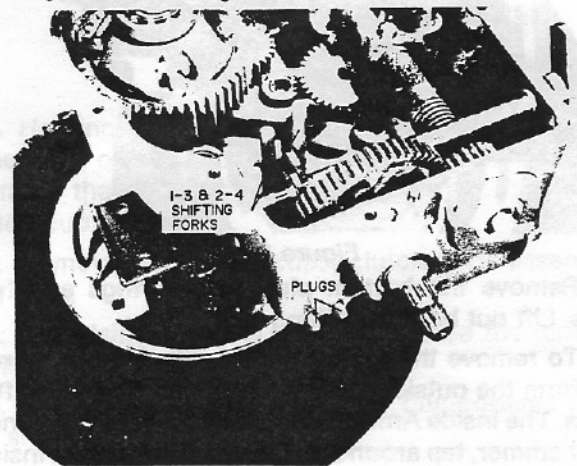

Figure 34

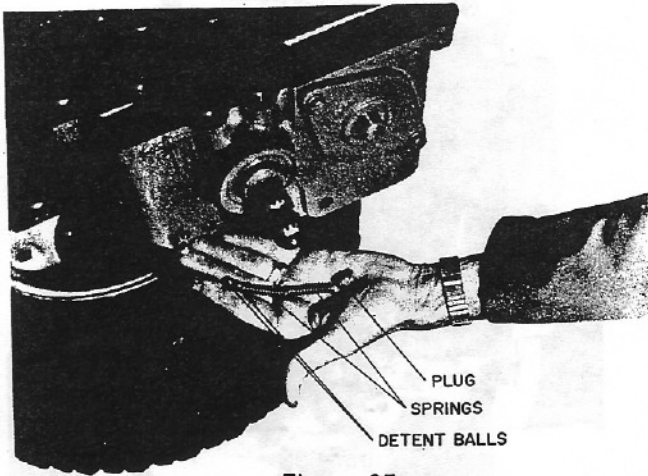

Figure 35

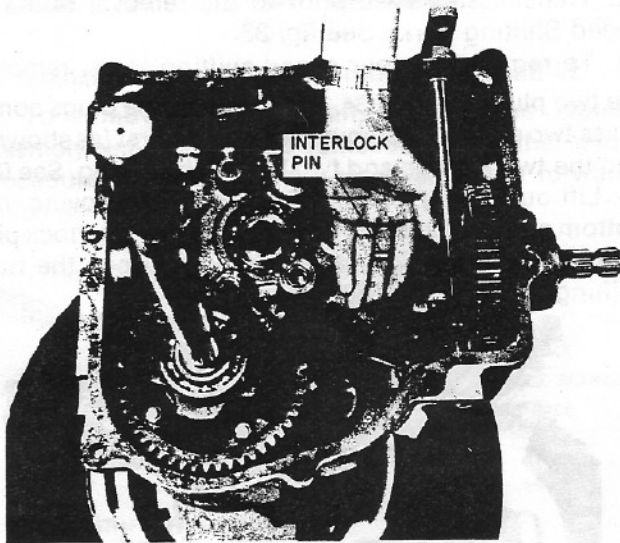

Figure 36

44. Remove the bottom plug, two springs and two balls. Lift out bottom shifting fork.

45. To remove the Shifter Weldment, remove the roll pin from the outside Shifter Arm. Remove the Shifter Arms. The inside Arm has a woodruff key. With a punch and hammer, tap around the brass bushing from inside to out and remove the bushing from the transmission case. Pull the Shifter Weldment through the transmission case.

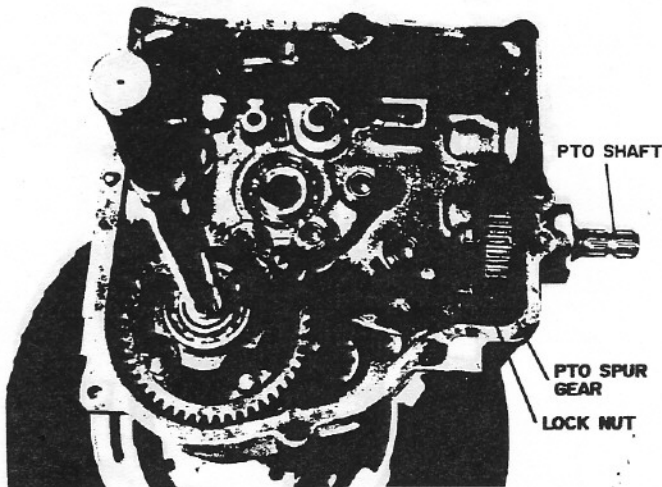

Figure 37

46. Transmission case prior to the removal of the P.T.O. Spur Gear and P.T.O. Shaft.

47. To remove the P.T.O. Spur Gear and P.T.O. Shaft block the Spur Gear from turning and remove the lock nut from the P.T.O. Shaft. Remove the Spur Gear from the Shaft and remove the P.T.O. Shaft from the transmission case.

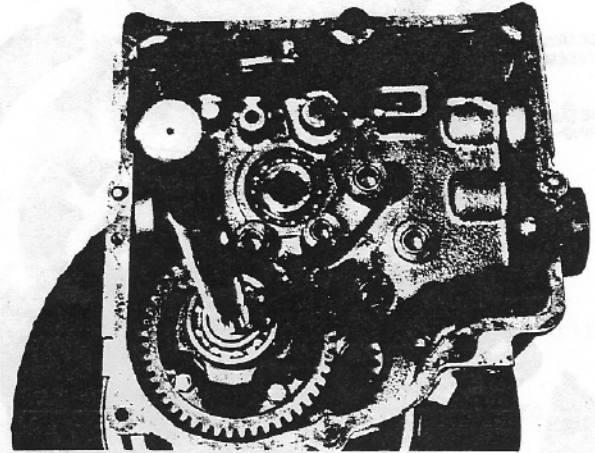

Figure 38

48. Transmission case prior to the removal of the Differential.

## DIFFERENTIAL ASSEMBLY REMOVAL

1. Lay the transmission case over, and block so left wheel is clear.
2. Remove the left wheel, wheel hub and axle bearing retainer from the axle as described in removal of the right side.
3. Remove the differential assembly from the transmission case.
4. Carefully examine the differential gears and bearings for wear or damage.

## DIFFERENTIAL DISASSEMBLY

5. Remove the four nuts from the four bolts through the differential.

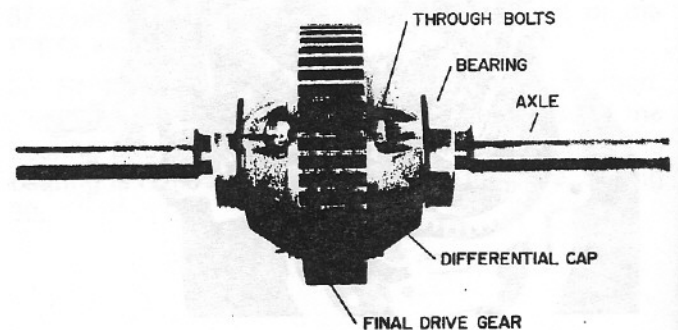
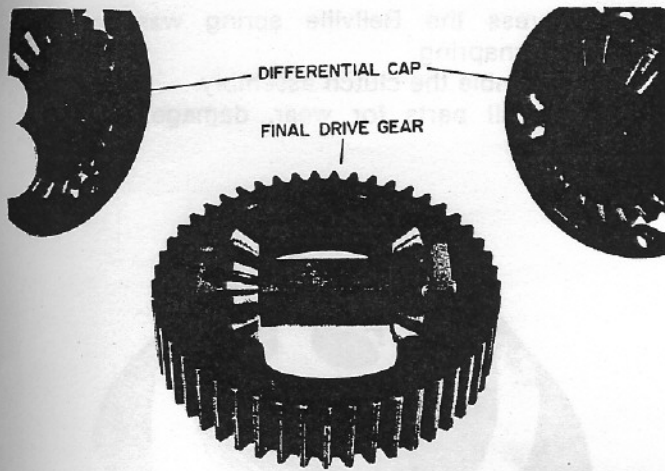

Figure 39

6. Separate the differential cap from the final drive gear



DIFFERENTIAL CAP  
FINAL DRIVE GEAR

Figure 40

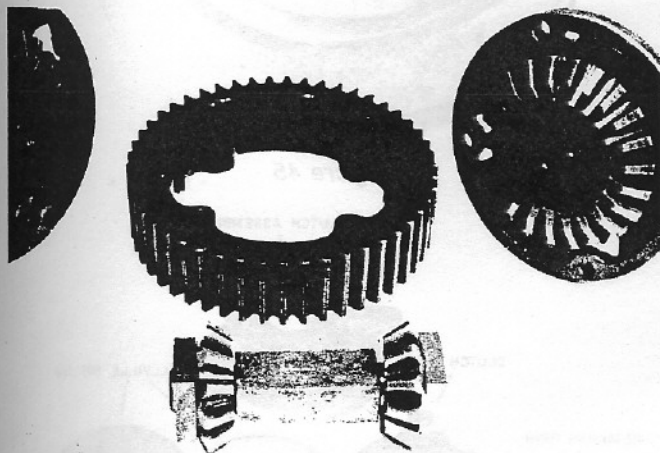

Figure 41

7. Carefully examine the assembly for wear or damage. Also, check the axle for splitting.

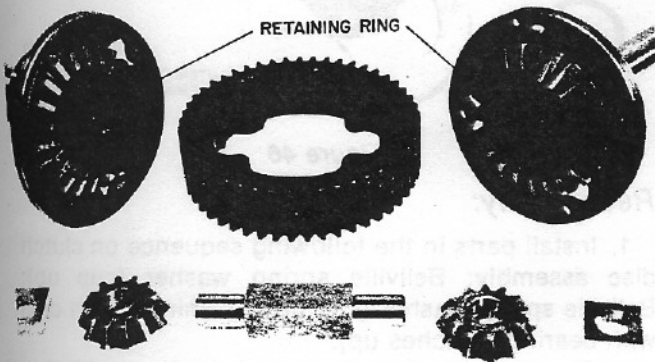

Figure 42

8. Replace any damaged or worn parts and reassemble.

## P.T.O. DISASSEMBLY

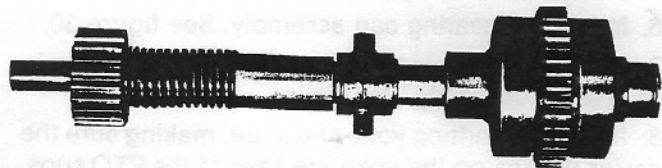

Figure 43

1. Holding the shifting collar assembly, press the exposed end of the PTO shaft and compress the spring. Remove the snapping on the PTO shaft inside the clutch cup.

2. Remove the clutch cups, clutch cone assembly and keys.

3. Exercising extreme caution, release the tension on the spring.

4. Remove the spring and other components from the shaft.

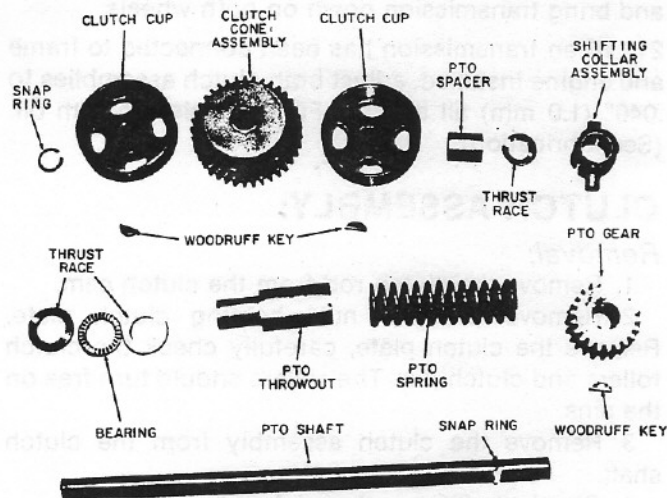

Figure 44

5. Carefully check part for wear on damage. Replace any part showing wear or damage.



## ASSEMBLY

1. Before reassembling the transmission carefully check the bearings and case for damage. Replace any bearings that are worn or damaged.

2. Coat the machined areas and bearings in the case with grease.

3. Install the differential assembly in the transmission case.

4. Install the left axle bearing retainer, wheel hub, woodruff key and wheel. Turn the transmission up on the left wheel.

5. Install the PTO assembly in the transmission case.

6. Install the bearing cap assembly. See figure 30.

7. Install the retaining ring on the PTO clutch cup in the bearing assembly. See figure

8. Install the shifting yoke and shaft, making sure the heavier prongs on the yoke are toward the PTO cups.

9. Install PTO lever, woodruff key and "E" ring.

10. Install the gear and shaft assemblies. Install High/Low shifting fork when installing #1 shaft.

11. Install detent ball, spring and plug securing the High/Low shifting fork.

12. Install transmission case cover.

13. Install transmission case cover bolts and "E" ring.

14. Install woodruff key, brake drum and "E" ring securing brake drum.

15. Install brake band and mounting bolt.

16. Install retaining ring on splined clutch shaft.

17. Install clutch assembly with cam toward top of transmission.

18. Install clutch plate, making sure the three (3) rollers and pins are in place. Install clutch plate with the roller on the long edge toward the top of the transmission. See figure 3 page 40.

19. Install the bearing retainer and four (4) bolts.

20. Install woodruff key, wheel hub, "E" ring, wheel and bring transmission down on both wheels.

21. When transmission has been connected to frame and engine installed, adjust both clutch assemblies to .040" (1.0 mm) all around. Fill transmission with oil. (See lubrication).

## CLUTCH ASSEMBLY:

### Removal:

1. Remove the clutch rod from the clutch cam.

2. Remove the two nuts holding clutch plate. Remove the clutch plate, carefully check the clutch rollers and clutch pin. The rollers should turn free on the pins.

3. Remove the clutch assembly from the clutch shaft.

4. Check shaft for rust or debris buildup.

To disassemble the clutch assembly:

1. Remove the spring and snapping from the bore of clutch disc assembly.

2. Compress the Bellville spring washers and remove the snapping.

3. Disassemble the clutch assembly.

4. Check all parts for wear, damage or debris buildup.

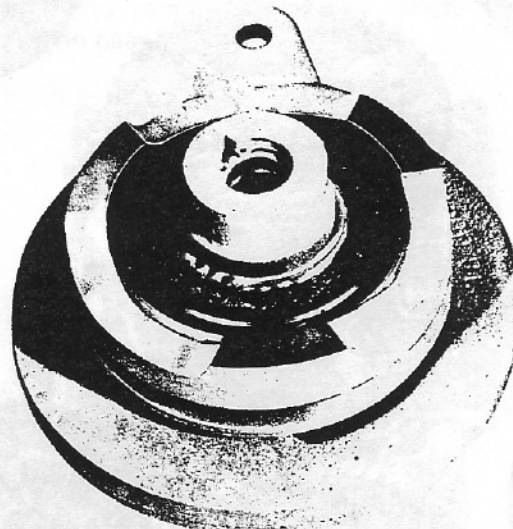

Figure 45

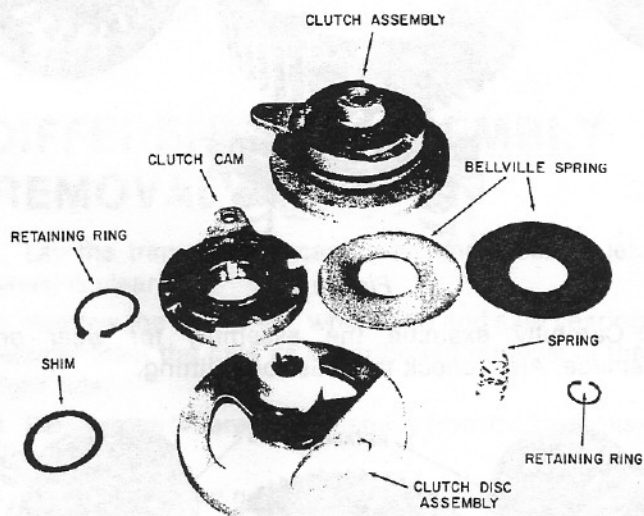

Figure 46

### Reassembly:

1. Install parts in the following sequence on clutch disc assembly: Bellville spring washer (cup up); Bellville spring washer (cup down); shim, clutch cam with bearing (notches up).

2. Compress the Bellville spring washer and install snapping.

3. Install spring and snapping in bore of clutch disc assembly.

### Installation:

1. Be sure shaft is clean and key is in place, slide the clutch assembly on shaft.

2. Place the clutch plate over the studs being sure the clutch pin and rollers remain in place.

3. Tighten the two nuts down until they are on or about .050" gap all around.