

**GRAVELLY®**

*18, 19, 22, 25, 29, 32*

**8000 SERIES  
GROUNDS  
MAINTENANCE  
TRACTORS  
PARTS CATALOG**

Form: 31185 (8/79)  
Printed in U.S.A.

TO CONTINUE ITS PROGRAM OF QUALITY AND DESIGN IMPROVEMENT, THE MANUFACTURER  
RESERVES THE RIGHT TO CHANGE SPECIFICATIONS, DESIGNS AND PRICES WITHOUT NOTICE  
AND WITHOUT INCURRING OBLIGATION



1 Gravelly Lane  
Clemmons, N. C. 27012

# TABLE OF CONTENTS

	Page
Transmission .....	1
Number One Shaft and Forward Clutch .....	2
Number Two Shaft and Reverse Clutch .....	3
Number Four Shaft and Idler Gears .....	4
Number Five Shaft, First Gear and Second Gear .....	4
Number Six Shaft, Brake Band and Sliding Gears .....	5
Number Seven Shaft, Pinion Shaft and Final Drive Gear .....	6
Number Eight Shaft and Differential .....	6
Number Nine Shaft and PTO Clutch .....	7
Number Ten Shaft and PTO Drive Gear .....	8
Number Eleven - Forward and Reverse Clutch .....	8
Number Twelve - Transmission Case .....	9
Number Thirteen - Transmission Cover .....	10
Manual Lift .....	11
Hydraulic System .....	12
Steering - Commercial Tractor .....	14
Steering - Consumer Tractor .....	15
Transmission Controls and Brake Lever Controls .....	16
Tractor Frame .....	18
Rear Hitch for Models 8102, 8122, 8123, 8129, 8162-B, 8163-B and 8169 .....	20
Rear Hitch for Models 8162-T, 8183-T, 8163-T, 8179 and 8199 .....	20
Engine, Fuel System and Exhaust System for Models 8102, 8122, 8128 and 8129 .....	21
Engine, Fuel System and Exhaust System for Models 8162-T, 8163-T, and 8183-T .....	22
Engine, Fuel System and Exhaust System for Models 8162-B, 8163-B and 8169 .....	23
Engine, Fuel System and Exhaust System for Model 8199 .....	24
Engine, Fuel System and Exhaust System for Model 8179 .....	25
Electric System for Models 8122 and 8123 .....	26
Electric System for Model 8102 .....	27
Electric System for Model 8128 and 8129 .....	28
Electric System for Models 8162-T, 8163-T and 8183-T .....	29
Electric System for Model 8169 .....	30
Electric System for Model 8199 .....	31
Electric System for Model 8179 .....	32
Electric System for Models 8162-B and 8163-B .....	33
Front and Rear Wheel .....	34
Wiring Diagram for 8102 .....	35
Wiring Diagram for 8122 and 8123 .....	35
Wiring Diagram for 8162-B, 8163-B, 8128 and 8129 .....	36
Wiring Diagram for 8162-T, 8163-T and 8183-T .....	36
Wiring Diagram for 8128-B, 8129, 8162-B and 8163-B .....	37
Wiring Diagram for 8199 .....	37
Wiring Diagram for 8169 .....	38
Wiring Diagram for 8179 .....	38

# TRANSMISSION

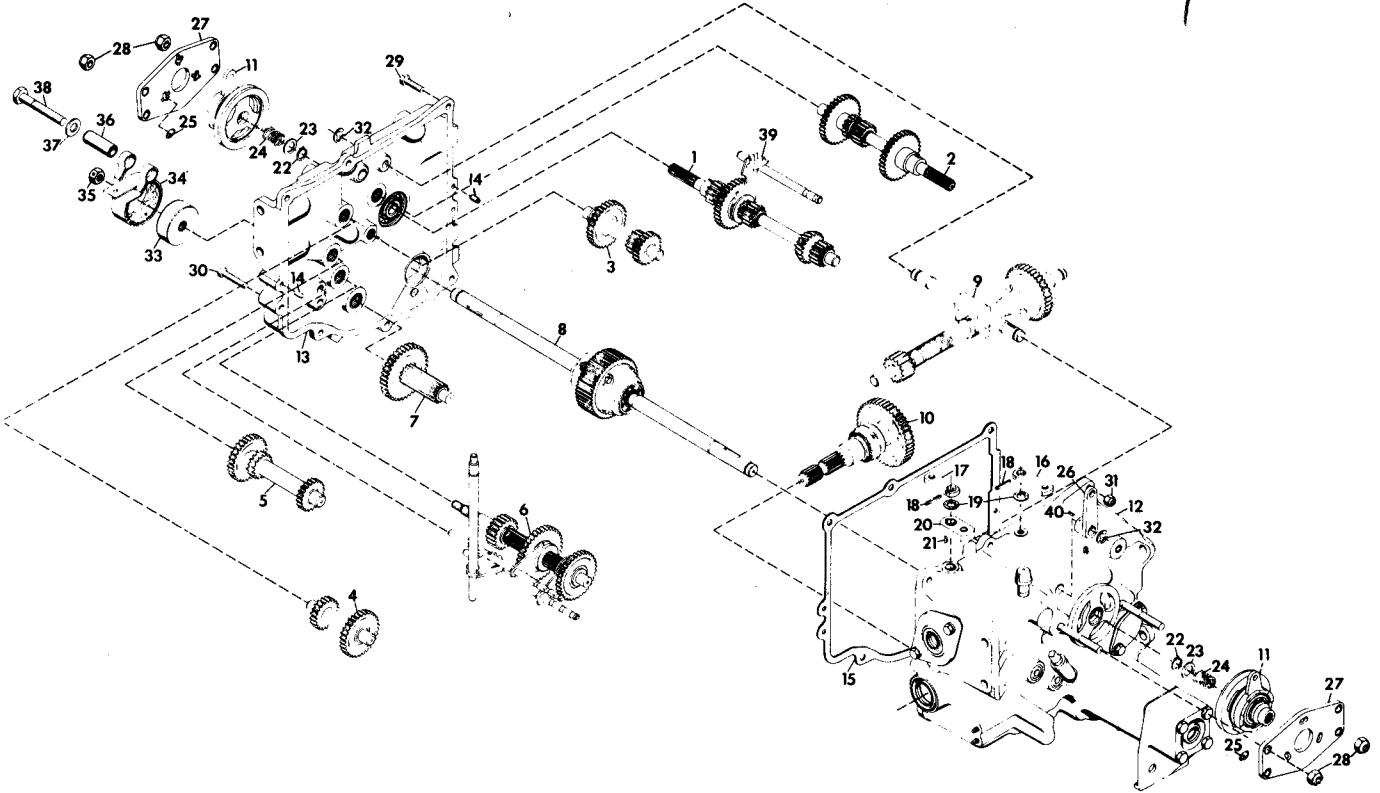

Item No.	Part No.	Qty.	Description
1	Refer To:		Number 1 Shaft, Forward Clutch
2	Refer To:		Number 2 Shaft, Reverse Clutch
3	Refer To:		Number 3 Shaft, 3rd and 4th Gear
4	Refer To:		Number 4 Shaft, Idler
5	Refer To:		Number 5 Shaft, 1st and 2nd Gear
6	Refer To:		Number 6 Shaft, Brake and Sliding Gear
7	Refer To:		Number 7 Shaft, Pinion and Final Drive
8	Refer To:		Number 8 Shaft, Differential Assembly
9	Refer To:		Number 9 Shaft, PTO Clutch Assembly
10	Refer To:		Number 10 Shaft, PTO Drive Assembly
11	Refer To:		Number 11, Forward-Reverse Clutch Assembly
12	Refer To:		Number 12, Transmission Case Assembly
13	Refer To:		Number 13, Transmission Cover Assembly
14	18089	2	Pin, Dowel; .375 x .625
15	18027	1	Gasket, Transmission Cover
16	17929	1	Arm, Shifter
17	17945	1	Arm, Shifter
18	421202	2	Pin, Spring; 3/16 x 1
19	21141	2	Washer, Felt; (Special for Trans.)
20	17944	1	Arm, Shifter
21	271089	1	Key, Woodruff; .125 x .375 Hard
22	11135	2	Ring, Retaining; .750 Shaft
23	11223	2	Race, Bearing Thrust; .752 x 1.240 x .030
24	20444	2	Spring, Comp Type; 1.0 x .80 x 36 Lb/in
25	23370	6	Roller, Clutch
26	18019	1	Lever, PTO
27	18047	2	Plate, Clutch
28	190171	4	Nut, Lock; 1/2-20 Washer Insert
29	180126	6	Bolt, Hex; 3/8-16 x 1-1/2
30	180132	2	Bolt, Hex; 3/8-16 x 2-1/4
31	456004	6	Nut, Lock; 3/8-16 Washer Insert Hex
32	11270	2	E-Ring; .750 Shaft
33	21371	1	Drum, Brake
34	18162	1	Band, Brake Asm.
35	124589	1	Nut, Hex; 5/8-11
36	18165	1	Bushing; .530 x .750 x 2.06
37	120396	1	Washer, Flat; .500 x 1.062 x .095
38	180188	1	Bolt, Hex; 1/2-13 x 2-3/4
39	17926	1	Weldment, Shifter
40	124549	1	Key, Woodruff; .187 x .750 Hard

# NUMBER ONE SHAFT AND FORWARD CLUTCH

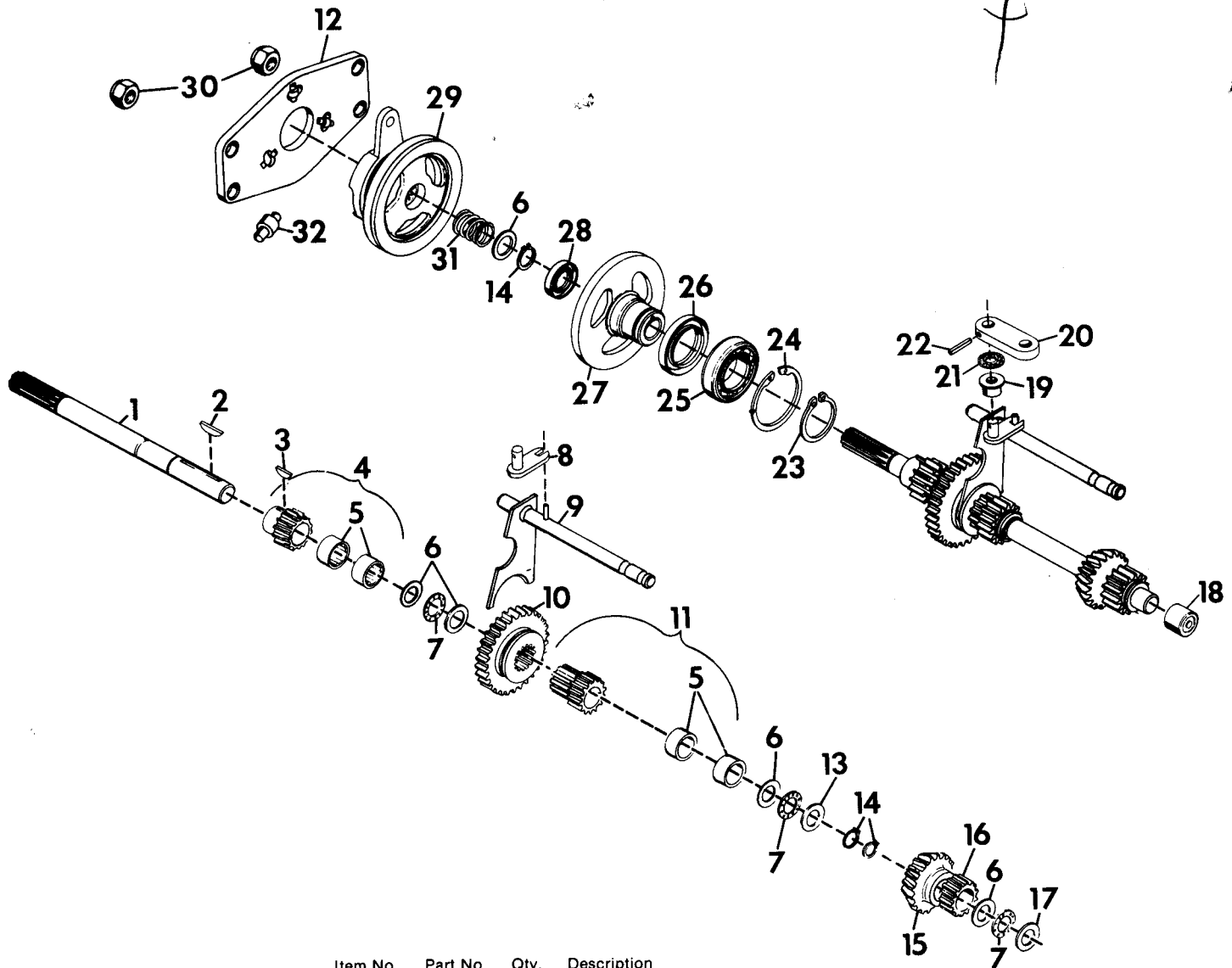

Item No.	Part No.	Qty.	Description
1	20447	1	Shaft, Splined Fwd Clutch
2	117989	1	Key, Woodruff; 3/16 x 1-1/4 Hard No. 19
3	431787	1	Key, Woodruff; .188 x .625 Hard
4	18025	1	Gear and Bearing Asm.
5	17949	4	Bearing Needle; 3/4 x 1 x 1/2
6	11223	5	Race, Bearing Thrust; .752 x 1.240 x .030
7	6741	3	Bearing, Needle Thrust; .752 x 1.240 x .078
8	17926	1	Weldment, Shifter
9	20755	1	Weldment, Shift Rail
10	18011	1	Gear, Spur; 2-Speed
11	18007	1	Gear and Bearing Asm.
12	18047	1	Plate, Clutch
13	6742	1	Race, Bearing Thrust; .060
14	11135	3	Ring, Retaining; .750 Shaft
15	18006	1	Gear, Bevel
16	18003	1	Gear, 10 DP 16 Teeth x .750 Standard
17	14998	1	Race, Bearing Thrust; .752 x 1.240 x .095
18	17913	1	Bearing, Needle; 3/4 x 1 x 3/4
19	17925	1	Bushing, 2-Speed
20	17929	1	Arm, Shifter
21	21141	1	Washer, Felt; (Special for Trans.)
22	421202	1	Pin, Spring; 3/16 x 1
23	17919	1	Ring, Retaining; 1.969 Shaft
24	18872	1	Ring, Retaining; 3.156 Bore
25	17915	1	Bearing, Ball; 1.968 x 3.149 x .629
26	17917	1	Seal, Oil; 2.250 x 3.005 x .375
27	18024	1	Hub, Clutch
28	18035	2	Seal, Oil; 3/4 x 1-5/8 x 1/4
29			Number 11, Forward-Reverse Clutch Assembly
30	190171	2	Nut, Lock; 1/2-20 Washer Insert
31	20444	1	Spring, Comp Type; 1.0 x .80 x 36 Lb/in
32	23370	3	Roller, Clutch

## NUMBER TWO SHAFT AND REVERSE CLUTCH

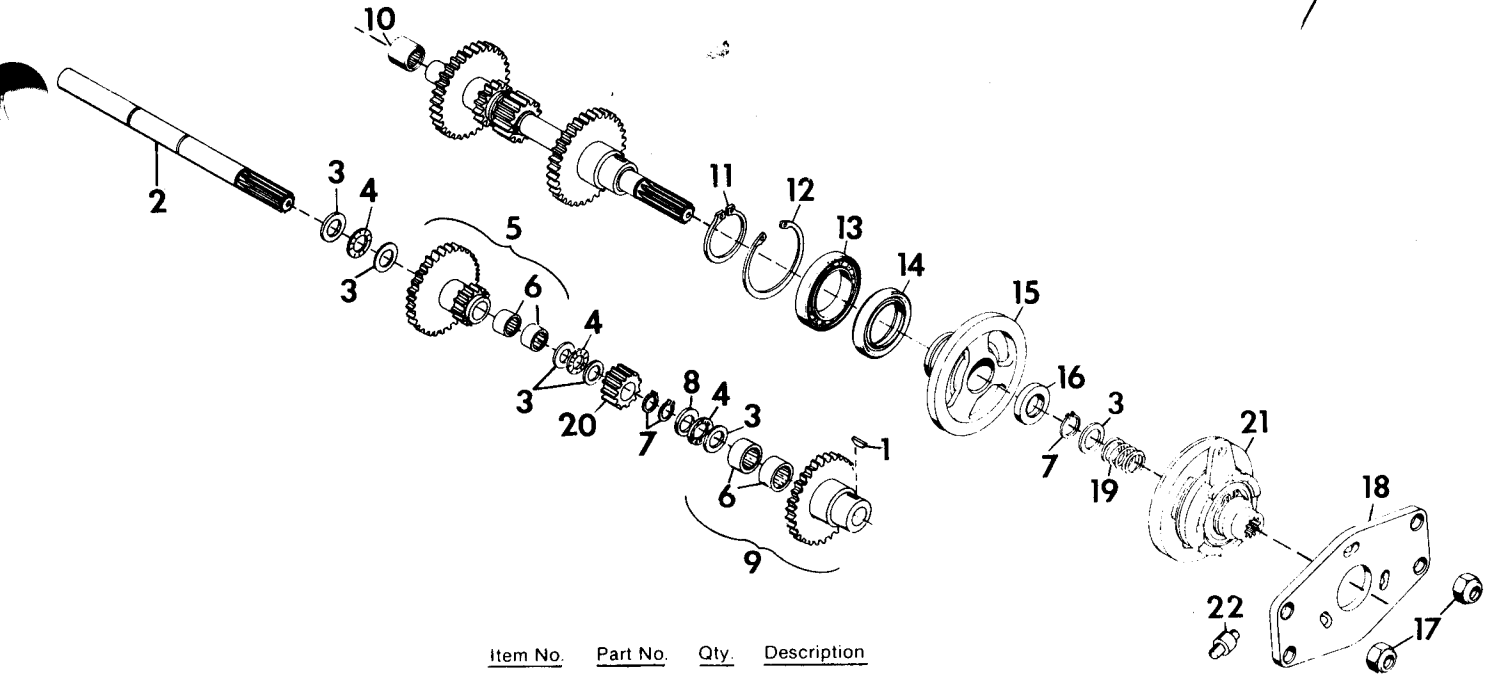

Item No.	Part No.	Qty.	Description
1	431787	1	Key, Woodruff; .188 x .625 Hard
2	20448	1	Shaft, Splined Rev Clutch
3	11223	6	Race, Bearing Thrust; .752 x 1.240 x .030
4	6741	3	Bearing, Needle Thrust; .752 x 1.240 x .078
5	18020	1	Gear, Idler Asm.
6	17949	4	Bearing, Needle; 3/4 x 1 x 1/2
7	11135	3	Ring, Retaining; .750 Shaft
8	6742	1	Race, Bearing Thrust; .060
9	17947	1	Assembly, Reverse Gear and Bearing
10	17913	1	Bearing, Needle; 3/4 x 1 x 3/4
11	17919	1	Ring, Retaining; 1.969 Shaft
12	18872	1	Ring, Retaining; 3.156 Bore
13	17915	1	Bearing, Ball; 1.968 x 3.149 x .629
14	17917	1	Seal, Oil; 2.250 x 3.005 x .375
15	18024	1	Hub, Clutch
16	18035	1	Seal, Oil; 3/4 x 1-5/8 x 1/4
17	190171	2	Nut, Lock; 1/2-20 Washer Insert
18	18047	1	Plate, Clutch
19	20444	1	Spring, Comp Type; 1.0 x .80 x 36 Lb/in
20	18003	1	Gear, 10 DP 16 Teeth x .750 Standard
21		1	Number 11, Forward-Reverse Clutch Assembly
22	23370	3	Roller, Clutch

## NUMBER THREE SHAFT, THIRD GEAR AND FOURTH GEAR

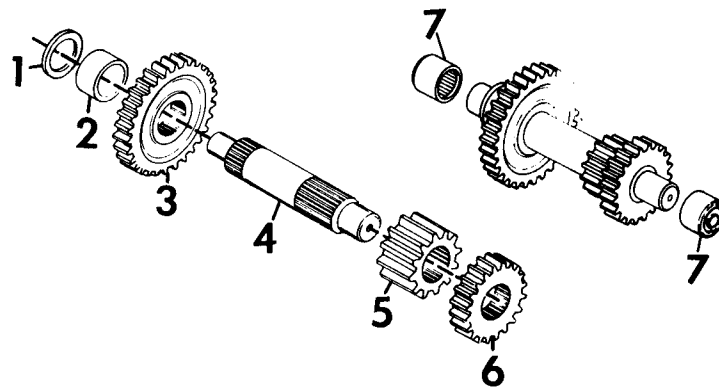

Item No.	Part No.	Qty.	Description
1	18000	1	Bearing, Thrust Race Torr Trc-1018
2	17999	1	Spacer, 1.027 x 1.125 x .457
3	19535	1	Gear
4	17997	1	Shaft, Splined
5	17992	1	Gear, 10 DP 16 Teeth x .750
6	15118	1	Gear, 10 DP 20 Teeth x .600
7	17914	2	Bearing, Needle; 5/8 x 13/16 x 3/4

## NUMBER FOUR SHAFT AND IDLER GEARS

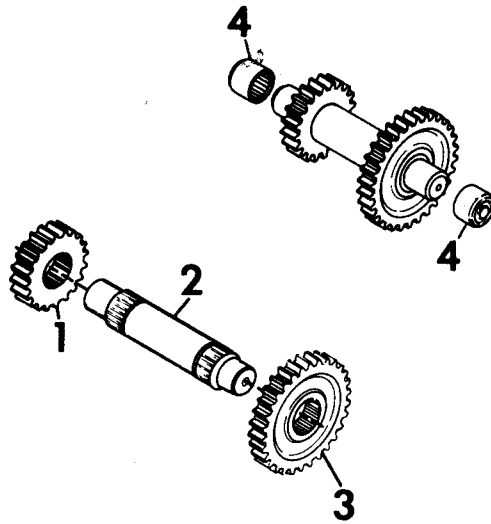

Item No.	Part No.	Qty.	Description
1	15118	1	Gear, 10 DP 20 Teeth x .600
2	17995	1	Shaft, Splined
3	15115	1	Gear, 10 DP 30 Teeth x .500
4	17913	2	Bearing, Needle; 3/4 x 1 x 3/4

## NUMBER FIVE SHAFT, FIRST GEAR AND SECOND GEAR

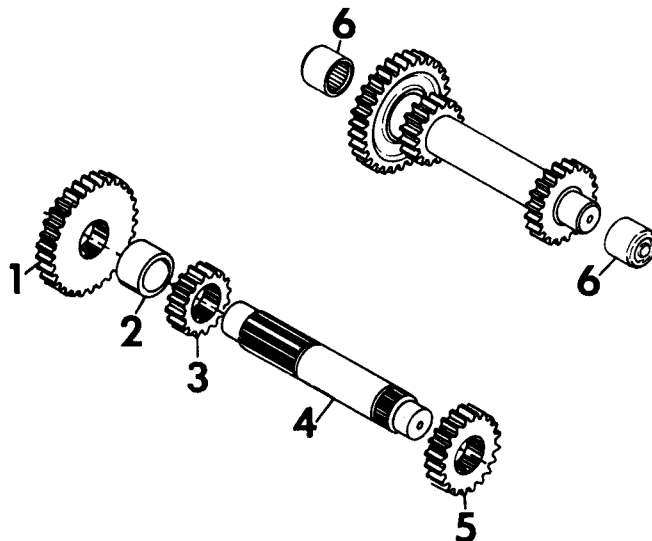

Item No.	Part No.	Qty.	Description
1	15115	1	Gear, 10 DP 30 Teeth x .500
2	17993	1	Spacer, 1.057 x 1.250 x .550
3	17992	1	Gear, 10 DP 16 Teeth x .750
4	17989	1	Shaft, Splined
5	15118	1	Gear, 10 DP 20 Teeth x .600
6	17913	2	Bearing, Needle; 3/4 x 1 x 3/4

# NUMBER SIX SHAFT, BRAKE BAND AND SLIDING GEARS

x

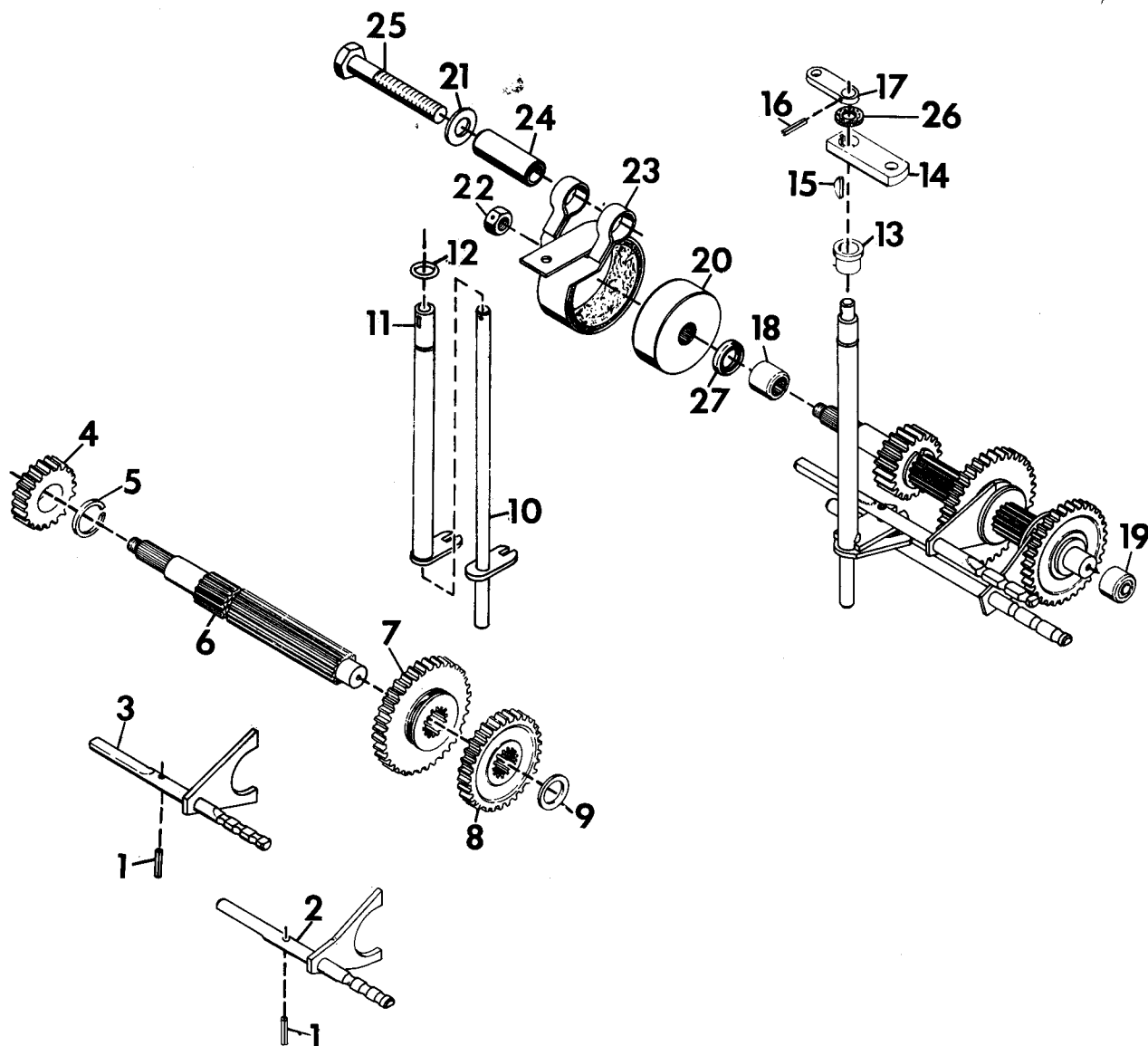

Item No.	Part No.	Qty.	Description
1	456390	2	Pin, Spring; 1/4 x 3/4
2	20762	1	Weldment, Rail Shift Fork 2 & 4 Range
3	20761	1	Weldment, Rail Shift Fork 1 & 3 Range
4	14988	1	Gear, 8 DP 16 Teeth x .850
5	14987	1	Ring, Retaining; 1.00 Shaft
6	21370	1	Shaft, Slide Gear
7	14989	1	Gear, Sliding; 10 DP, 30 Teeth x .594
8	14995	1	Gear, Sliding; 10 DP, 36 Teeth x .594
9	14998	1	Race, Bearing Thrust; .752 x 1.240 x .095
10	17937	1	Weldment, 2nd and 4th Shifter
11	17940	1	Weldment, 1st and 3rd Shifter
12	18018	1	O-Ring; 5/8 x 3/4 x 1/16
13	17943	1	Bushing; .756 x 1.125 x .75
14	17944	1	Arm, Shifter
15	271089	1	Key, Woodruff; .125 x .375 Hard
16	421202	1	Pin, Spring; 3/16 x 1
17	17945	1	Arm, Shifter
18	11063	1	Bearing, Needle; 3/4 x 1 x 3/4
19	17913	1	Bearing, Needle; 3/4 x 1 x 3/4
20	21371	1	Drum, Brake
21	120396	1	Washer, Flat; .500 x 1.062 x .095
22	124589	1	Nut, Hex; 5/8-11
23	18162	1	Band, Brake Asm.
24	18165	1	Bushing; .530 x .750 x 2.06
25	180188	1	Bolt, Hex; 1/2-13 x 2-3/4
26	21141	1	Washer, Flat; (Special for Trans.)
27	15137	1	Seal, Oil; .750 x 1.254 x .188





# NUMBER NINE SHAFT AND PTO CLUTCH

X

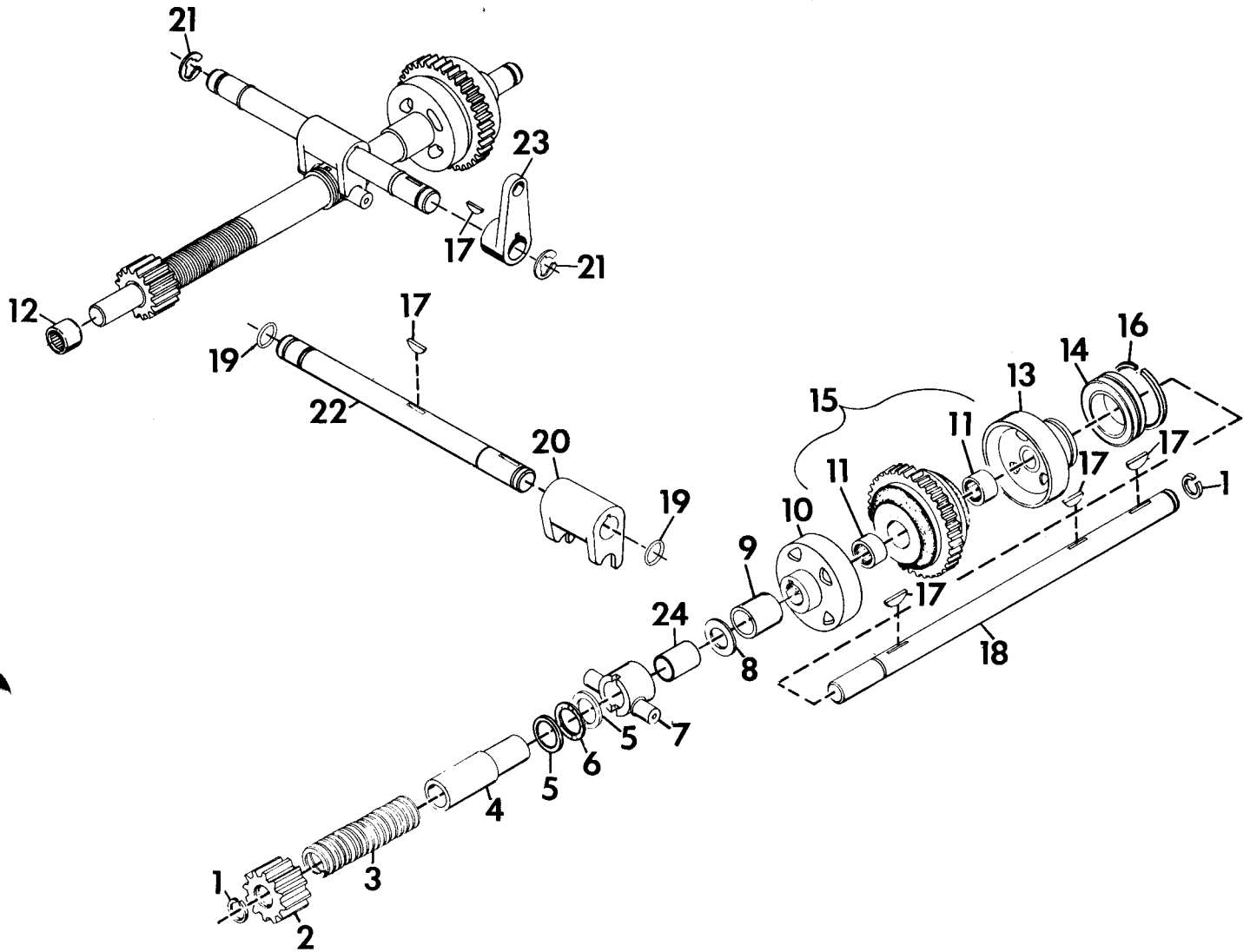

Item No.	Part No.	Qty.	Description
1	15733	2	Ring, Retaining; .750 Shaft
2	17965	1	Gear, Spur PTO; 10 DP 22 Teeth x 1.200 Std.
3	17964	1	Spring, Comp Type; 5 x 1.50 x 200 Rate
4	17963	1	Throw-Out, PTO
5	17959	2	Bearing, Thrust Race
6	11225	1	Bearing, Needle Thrust; 1.002 x 1.552
7	17960	1	Assembly, Shifting Collar
8	14998	1	Race, Bearing, Thrust; .752 x 1.240 x .095 Torr Trc-1220
9	17958	1	Spacer, PTO
10	17957	1	Cup, Clutch
11	17949	2	Bearing, Needle; 3/4 x 1 x 1/2
12	9960	1	Bearing, Torrington B-128 (B-128-OH)
13	17952	1	Cup, Clutch
14	17967	1	Bearing, Ball; 1.378 x 2.440 x .551
15	17953	1	Cone, Clutch Brg. Assy.
16	17966	1	Ring, Retaining; 1-3/8 Eaton 340-1
17	124549	5	Key, Woodruff; .187 x .750 Hard
18	17951	1	Shaft, PTO Clutch
19	18018	2	O-Ring; 5/8 x 3/4 x 1/16
20	18016	1	Yoke, PTO
21	11270	2	E-Ring; .750 Shaft
22	18017	1	Shaft, PTO Yoke
23	18019	1	Lever, PTO
24	17962	1	Bushing

## NUMBER TEN SHAFT AND PTO DRIVE GEAR

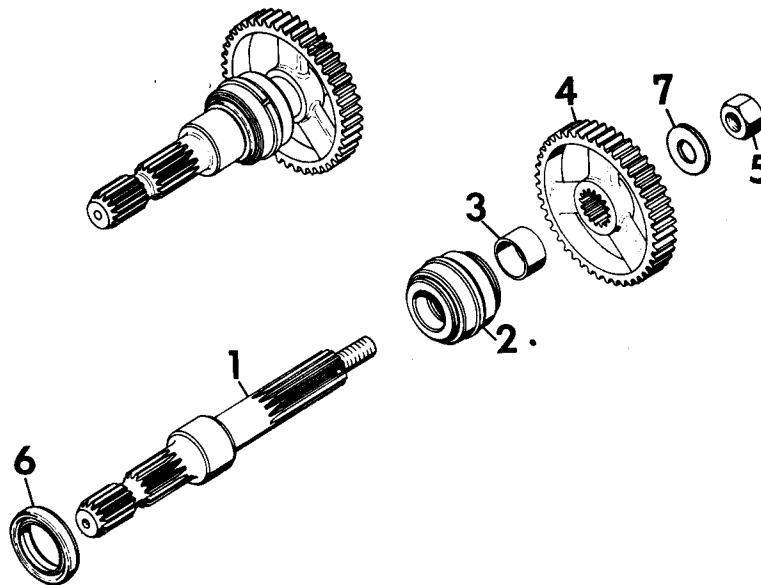

Item No.	Part No.	Qty.	Description
1	19538	1	Shaft, PTO
2	14640	1	Assembly, Bearing; 1.000 x 1.980 x 1.243
3	17924	1	Spacer; 1.060 x 1.250 x .450
4	17922	1	Gear, Spur PTO; 10 DP 56 Teeth x .750 Std.
5	124589	1	Nut, Hex; 5/8-11
6	17923	1	Seal, Oil; 1.375 x 2.129 x .312
7	421879	1	Washer, Flat .656 x 1.250 x .100

## NUMBER ELEVEN - FORWARD AND REVERSE CLUTCH

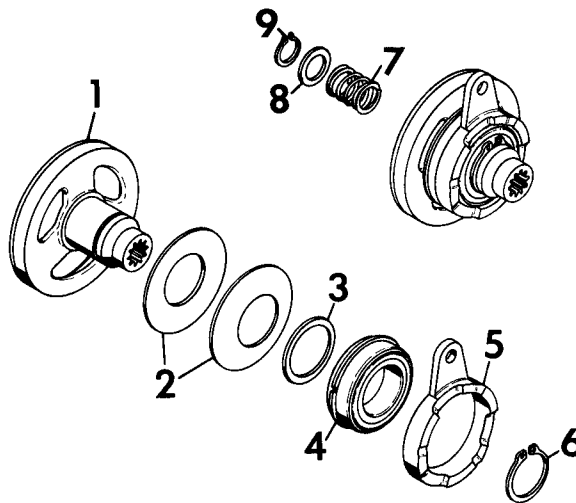

Item No.	Part No.	Qty.	Description
1	20449	1	Assembly, Clutch Disc
2	18041	2	Spring, Belleville
3	18548	1	Shim (.030) Fwd-Rev Clutch
4	18042	1	Bearing, Ball; 1.574 x 3.149 x .708
5	19063	1	Cam, Clutch
6	18043	1	Ring, Retaining; 1.562 Shaft
7	20444	1	Spring, Comp Type; 1.0 x .80 x 36 LB/IN
8	11223	1	Race, Bearing Thrust; .752 x 1.240 x .030
9	11135	1	Ring, Retaining; .750 Shaft

# NUMBER TWELVE - TRANSMISSION CASE

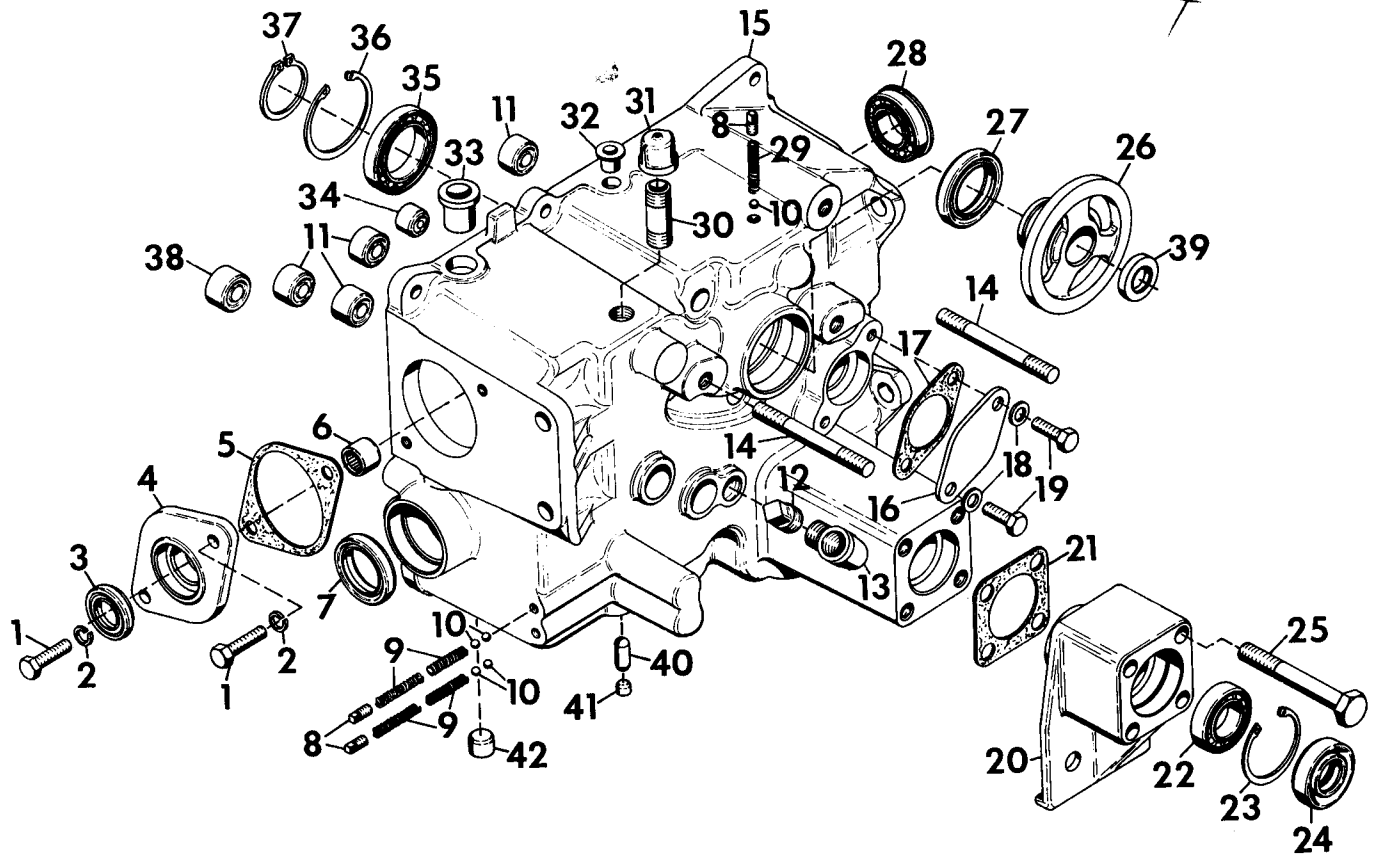

Item No.	Part No.	Qty.	Description
1	180079	2	Bolt, Hex; 5/16-18 x 1
2	120214	2	Washer, Lock; 5/16 SP
3	15137	1	Seal, Oil; .750 x 1.254 x .188
4	18859	1	Cap, Front PTO
5	18857	1	Gasket, Front Cap
6	9660	1	Bearing, Torrington B-128 (B-128-OH)
7	17923	1	Seal, Oil; 1.375 x 2.129 x .312
8	103877	3	Plug, Pipe; 1/8 In. SQ HD Steel
9	17936	4	Spring, Compression; 1.50 x .30 x 26 LB/IN
10	274301	5	Ball, Steel; 5/16
11	17913	4	Bearing, Needle; 3/4 x 1 x 3/4
12	103880	1	Plug, Pipe; 1/2 In. SQ HD Steel
13	108686	1	Elbow, 1/2 90 Degree Street
14	18036	2	Stud, Clutch
15	17910	1	Assembly, Transmission Case
16	18421	1	Plate, Cover
17	18422	1	Gasket, Cover Plate
18	120394	2	Washer, Flat; .406 x .812 x .065
19	180120	2	Bolt, Hex; 3/8-16 x .750
20	18810	1	Retainer, Axle Brg. L.H.
21	18030	1	Gasket
22	18029	1	Bearing, Ball; 1.250 x 2.250 x .500
23	18812	1	Ring, Retaining
24	18031	1	Seal, Oil Axle
25	180191	4	Bolt, Hex; 1/2-13 x 3-1/4 x .551
26	18024	1	Hub, Clutch
27	17917	1	Seal, Oil; 2.250 x 3.005 x .375
28	17967	1	Bearing, Ball; 1.378 x 2.440
29	24772	1	Spring
30	121664	1	Nipple, Pipe; 1/2 x 2-1/2
31	19472	1	Cap, Pipe; 1/2 NPT
32	17925	1	Bushing, 2-Speed
33	17943	1	Bushing; .756 x 1.125 x .75
34	17914	1	Bearing, Needle; 5/8 x 13/16 x 3/4
35	17915	1	Bearing, Ball; 1.968 x 3.149 x .629
36	18872	1	Ring, Retaining; 3.156 Bore
37	17919	1	Ring, Retaining; 1.969 Shaft
38	17912	1	Bearing, Needle; 1.000 x 1.250 x .750
39	18035	1	Seal, Oil; 3/4 x 1-5/8 x 1/4
40	18200	1	Pin, Interlock
41	421743	1	Plug, Cup; 3/8
42	17946	1	Plug

# NUMBER THIRTEEN - TRANSMISSION COVER

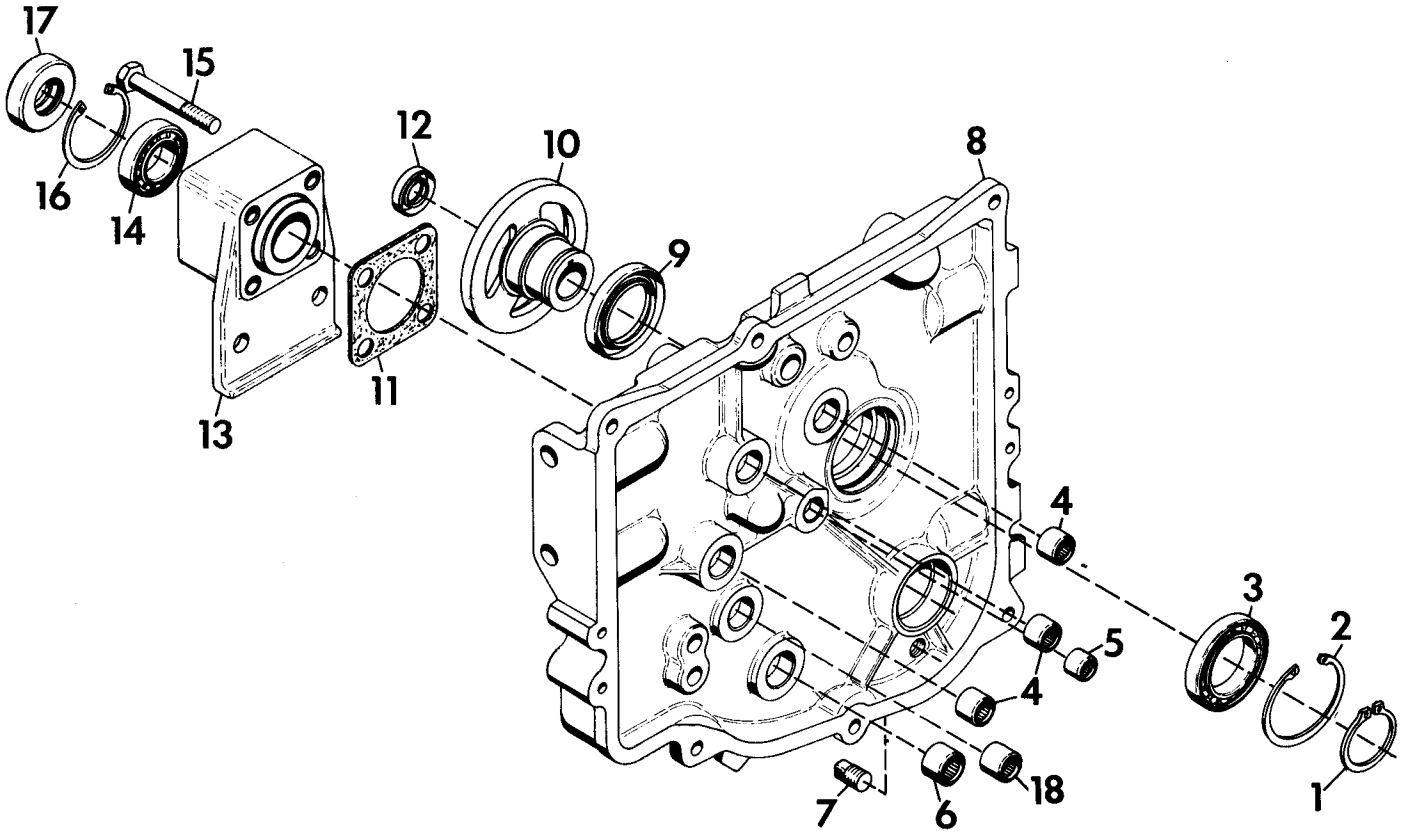

Item No.	Part No.	Qty.	Description
1	17919	1	Ring, Retaining; 1.969 Shaft
2	18872	1	Ring, Retaining; 3.156 Bore
3	17915	1	Bearing, Ball; 1.968 x 3.149 x .629
4	17913	3	Bearing, Needle; 3/4 x 1 x 3/4
5	17914	1	Bearing, Needle; 5/8 x 13/16 x 3/4
6	17912	1	Bearing, Needle; 1.000 x 1.250 x .750
7	103879	1	Plug, Pipe; 3/8 IN SQ HD Steel
8	18022	1	Trans, Cover Assy.
9	17917	1	Seal, Oil; 2.250 x 3.005 x .375
10	18024	1	Hub, Clutch
11	18030	1	Gasket
12	18035	1	Seal, Oil; 3/4 x 1-5/8 x 1/4
13	18810	1	Retainer, Axle Brg. L.H.
14	18029	1	Bearing, Ball; 1.250 x 2.250 x .500
15	180191	4	Bolt, Hex; 1/2-13 x 3-1/4
16	18812	1	Ring, Retaining
17	18031	1	Seal, Oil Axle
18	11063	1	Bearing, Needle; 3/4 x 1 x 3/4

# MANUAL LIFT

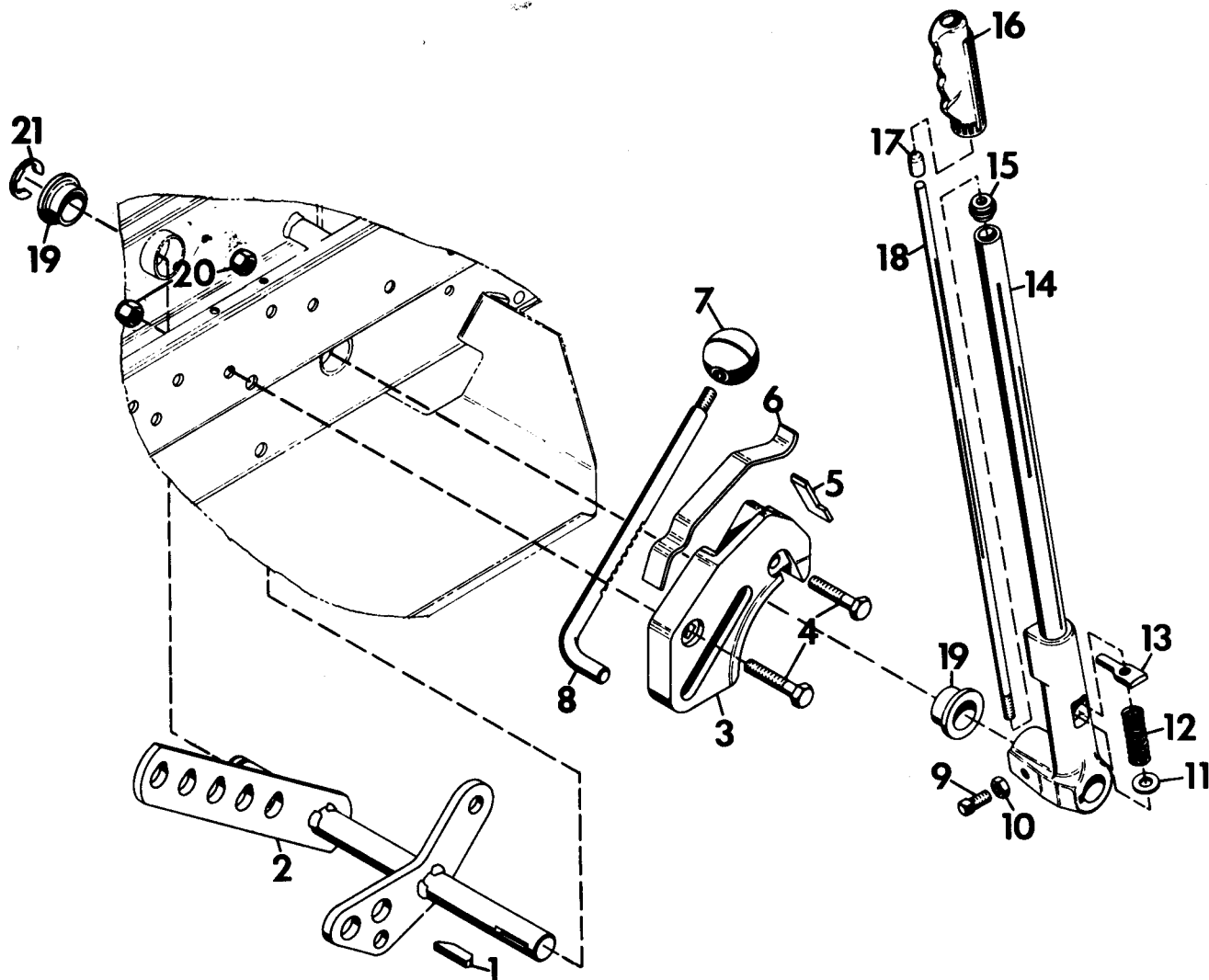

Item No.	Part No.	Qty.	Description
1	187184	1	Key, Woodruff; .250 x 2.125 Soft
2	18404	1	Shaft, Lift Lever Weldment
3	11103	1	Casting, Locator
4	180124	2	Bolt, Hex; 3/8-16 x 1-1/4
5	11106	1	Stop, Lever
6	11105	1	Spring, Stop
7	10670	1	Knob, Control
8	18732	1	Rod, Lever Stop
9	102897	1	Screw, Set; 3/8-16 x 1-1/4 SQ HD Cup Point
10	124829	1	Nut, Jam; 3/8-16 Hex
11	11670	1	Washer, Special Flat; .45 x .99 x .10
12	10682	1	Spring, Compression; 2 x .720 x 15.5 LB/IN
13	11116	1	Pawl, Lever
14	11113	1	Assembly, Lever Lift
15	11117	1	Guide, Push Rod
16	11119	1	Grip, Flex
17	19367	1	Tip, Push Rod
18	11118	1	Rod, Lever Push
19	18355	2	Bushing, Pivot
20	456004	2	Nut, Lock; 3/8-16 Washer Insert Hex
21	11112	1	E-Ring; 1.000 Shaft Copper

# HYDRAULIC SYSTEM

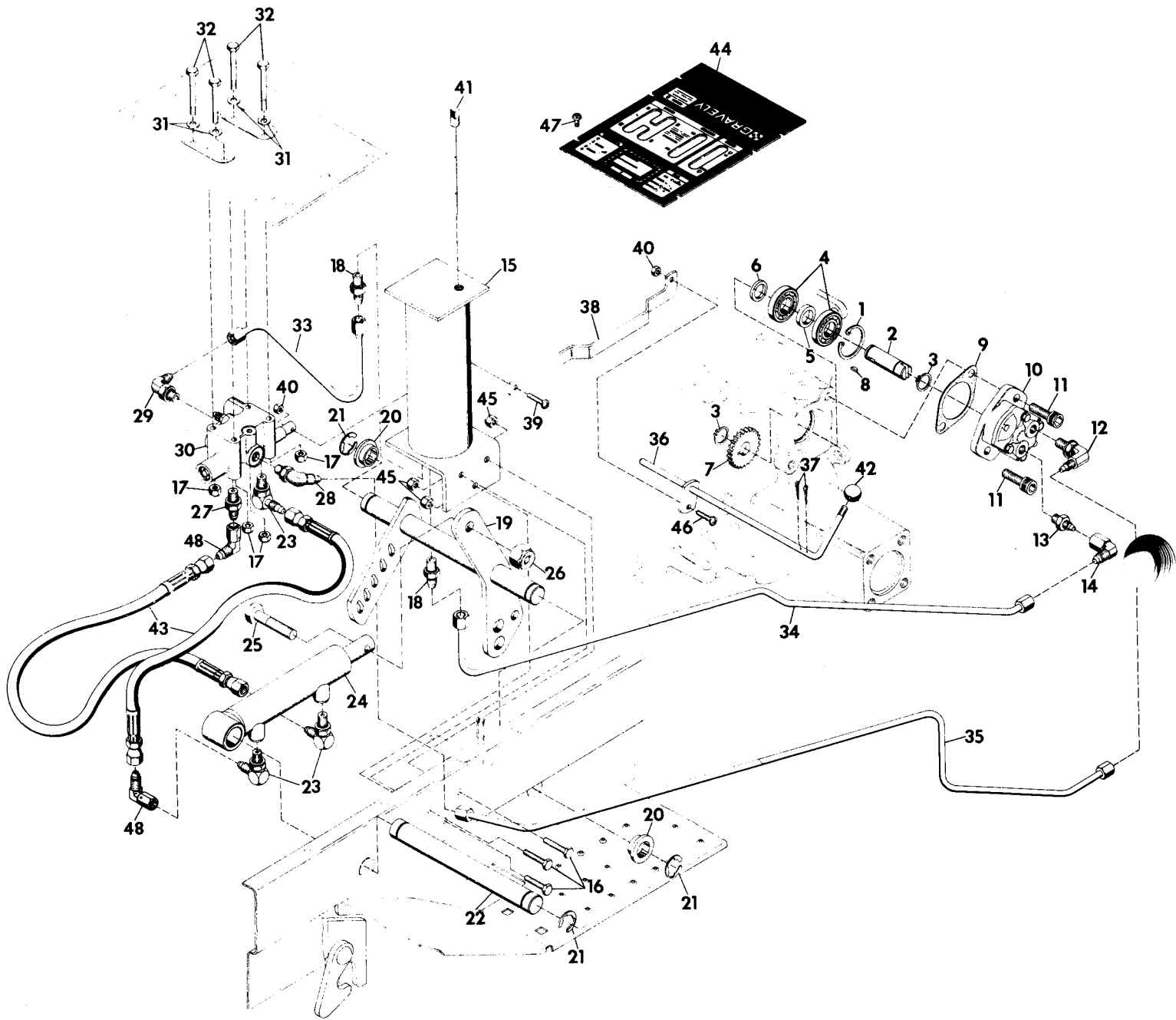

X

<u>Item No.</u>	<u>Part No.</u>	<u>Qty.</u>	<u>Description</u>
1	18799	1	Ring, Retaining; 1.378 Bore
2	18797	1	Shaft, Hyd Pump
3	18809	2	Ring, Retaining; .594 Shaft
4	12626	2	Bearing, Ball; .590 x 1.3780 x .433
5	18807	1	Spacer, .588 x .620 x .750
6	18798	1	Spacer, .620 x .750 x .364
7	18808	1	Gear, Hyd Pump
8	271089	1	Key, Woodruff; .125 x .375 Hard
9	18422	1	Gasket, Cover Plate
10	18813	1	Pump, Hydraulic
11	426370	2	Screw, Cap; 3/8-16 Hex Socket HD
12	18816	1	Adapter (P-H #2503-8-6)
13	18817	1	Adapter (P-H #0503-10-6)
14	18818	1	Adapter (P-H #3903-6-6)
15	22460	1	Weldment, Hyd Tank
16	180122	3	Bolt, Hex; 3/8-16 x 1
17	419454	4	Nut, Lock; 1/4-20 Washer Insert
18	19167	2	Adapter (P-H #050-6-6)
19	18822	1	Weldment, Lift Lever Shaft
20	18355	2	Bushing, Pivot
21	11112	2	E-Ring; 1.000 Shaft Cover
22	18830	1	Shaft, Hyd. Cyl.
23	18826	3	Adapter (P-H #2503-4-4)
24	31284	1	Cylinder, Hydraulic
25	180181	1	Bolt, Hex; 1/2-13 x 2
26	435507	1	Nut, Lock; 1/2-13 Washer Insert
27	21286	1	Adapter (P-H #0503-4-4)
28	18829	1	Adapter (P-H #3503-6-6)
29	18828	1	Adapter (P-H #2503-6-6)
30	18825	1	Valve, Hydraulic
31	120392	4	Washer, Flat; .281 x 6.25 x .065
32	180050	4	Bolt, Hex; 1/4-20 x 2-3/4
33	19165	1	Line, Return Valve to Tank
34	19166	1	Line, Hyd. (in) Tank to Pump
	31283	1	Line, Hyd. (in) Tank to Pump Com.
35	18843	1	Line, Hyd. (out) Valve to Pump
	31282	1	Line, Hyd. (out) Valve to Pump Com.
36	18833	1	Rod, Weldment Hyd Valve
37	121224	2	Pin, Cotter; .094 x 1.000
38	18836	1	Rod, Hyd. Control
	31303	1	Rod, Hyd. Control Com.
39	132848	1	Screw, Machine; 10-24 x 1 RD HD
40	190254	2	Nut, Lock; 10-24 Washer Insert
41	22457	1	Gauge, Hyd Tank Level
42	11261	1	Knob, Adj. Control
43	18845	2	Hose, Hyd 14.5 66
44	31165	1	Plate, Control Cover Hyd.
	31276	1	Plate, Control Cover Hyd. Com.
45	456004	3	Nut, Lock; 3/8-16 Washer Insert Hex
46	120910	1	Screw, Machine; 10-24 x 3/4 RD HD
47	167257	6	Screw, Tapping; 1/4-20 x 1/2 Pan HD C-Recess
48	21287	1	Adapter (P-H #3903-4-4)



# STEERING - COMMERCIAL TRACTOR

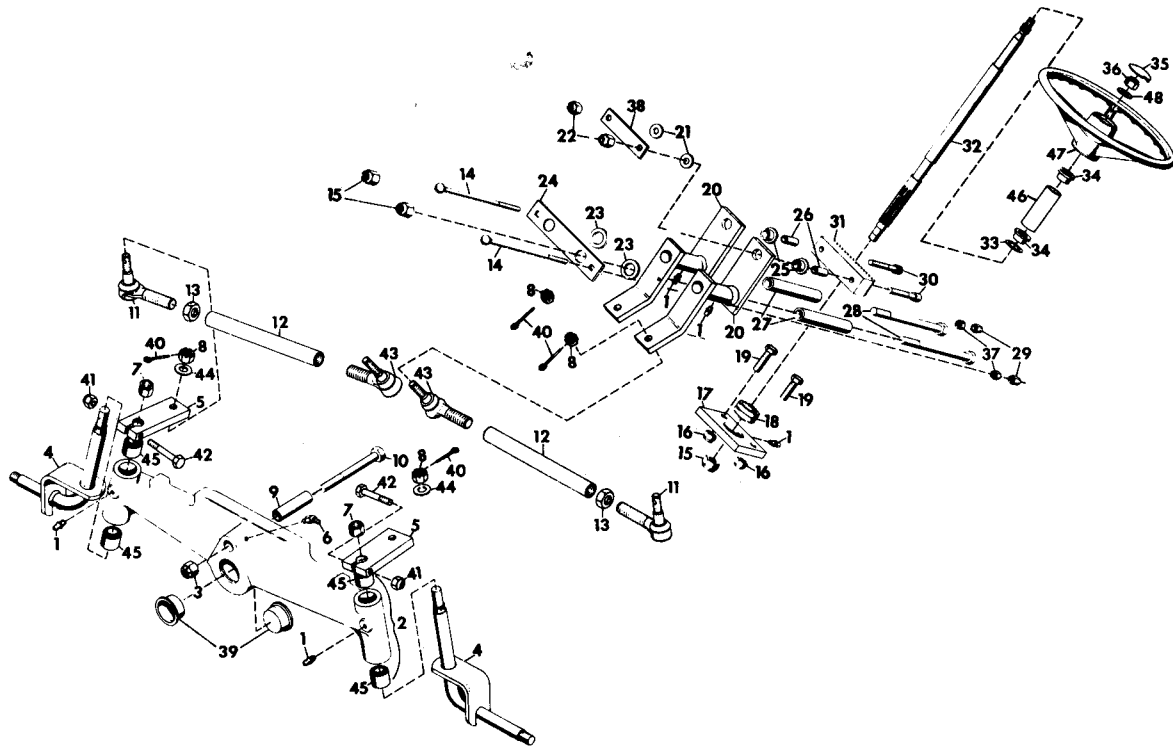

Item No.	Part No.	Qty.	Description
1	411027	5	Fitting, Lube; 1/4-28
2	23312	1	Assembly, Steering Axle
3	456007	1	Nut, Lock; 3/4-10 Washer Insert
4	18463	2	Weldment, King Pin
5	31270	2	Arm, Axle Tie Rod
6	411031	1	Fitting, Lube; 1/4-28 45 Deg. Elbow
7	124589	2	Nut, Hex; 5/8-11
8	125233	4	Nut, Hex Slotted; 3/8-24
9	23237	1	Tube, Axle Pivot
10	271781	1	Bolt, Hex; 3/4-10 x 4-1/2
11	21668	2	Assembly, Rod End; RH
12	23209	2	Tube, Tie Rod
13	124934	2	Nut, Jam; 1/2-20
14	126952	2	Bolt; 5/16-18 x 5-1/2 RD HD SQ NK
15	435507	3	Nut, Lock; 1/2-13 Washer Insert
16	419456	2	Nut, Lock; 7/16-14 Washer Insert Hex
17	21148	1	Block Bearing Support
18	21147	1	Bearing, Spherical
19	180149	2	Bolt, Hex; 7/16-14 x 1-1/2
20	31304	2	Weldment, Steering Arm
21	446470	2	Washer, Flat; .375 x 1.125 x .065
22	456004	2	Nut, Lock; 3/8-16 Washer Insert Hex
23	14998	2	Race, Bearing Thrust; .752 x 1.240 x .095
24	21079	1	Plate, Adjustment
25	21077	2	Bearing, Flange (P/M Bronze)
26	21076	2	Bushing; .391 x .622 x .670
27	21078	2	Sleeve, Pivot
28	443734	2	Bolt, Hex; 1/2-13 x 6
29	419455	2	Nut, Lock; 5/16-18 Washer Insert Hex
30	454473	2	Screw, Cap; 3/8-16 x 2 Hex Socket HD
31	21075	1	Gear, Rack
32	24442	1	Shaft, Steering Wheel
33	20273	1	Ring, Retaining; Int. Tooth 1.000 Shaft
34	10174	2	Bushing, Nylon; .760 x 1.000 x .600 Flange
35	23376	1	Insert, Steering Wheel Models 8128, 8129 & 8169
	31426	1	Insert, Steering Wheel Models 8179 & 8199
36	418692	1	Nut, Lock; 5/8-11 Washer Insert Hex
37	120376	2	Nut, Hex; 5/16-18
38	21246	1	Strap, Rack and Pinion
39	18785	2	Cap, Front Axle
40	121222	4	Pin, Cotter; .09 x .75
41	190139	2	Nut, Lock; 5/16-24 Washer Insert
42	181018	2	Bolt, Hex; 5/16-24 x 1-3/4
43	21669	2	Assembly, Rod End; L.H.
44	120388	2	Washer, Flat; .438 x 1.000 x .038
45	23241	4	Bushing; .877 x 1.004 x 1.0
46	24438	1	Bushing, Steering Wheel
47	24490	1	Wheel, Steering Models 8128, 8129 & 8169
	31281	1	Wheel, Steering Models 8179 & 8199
48	131016	1	Nut, Lock; 5/8-11 Washer Insert Hex

# STEERING - CONSUMER TRACTOR

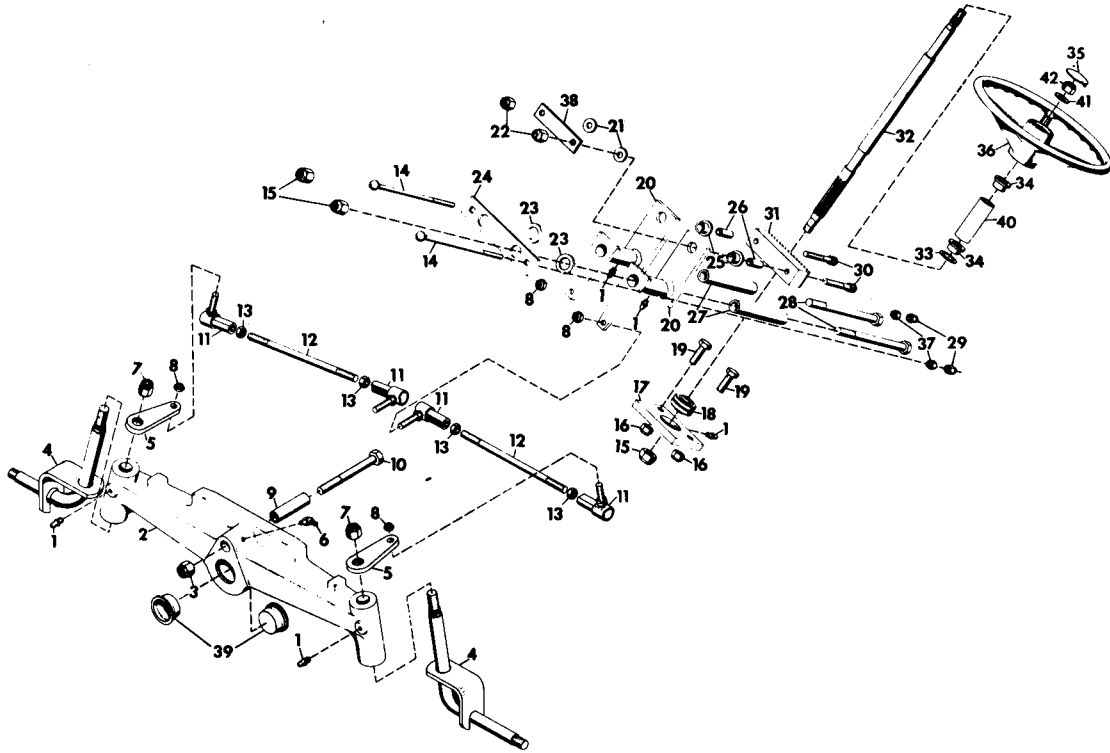

Item No.	Part No.	Qty.	Description
1	411027	5	Fitting, Lube; 1/4-28
2	23312	1	Assembly, Steering Axle
3	456007	1	Nut, Lock; 3/4-10 Washer Insert
4	18463	2	Weldment, King Pin
5	18461	2	Arm, Tie Rod
6	411031	1	Fitting, Lube; 1/4-28 45 Deg. Elbow
7	124589	2	Nut, Hex; 5/8-11
8	192481	4	Nut, Lock; 3/8-24 Washer Insert Hex
9	23237	1	Tube, Axle Pivot
10	271781	1	Bolt, Hex; 3/4-10 x 4-1/2
11	21084	4	Ball Joint, Steering
12	21085	2	Rod, Steering Tie
13	120369	4	Nut, Hex; 3/8-24
14	126952	2	Bolt; 5/16-18 x 5-1/2 RD HD SQ NK
15	435507	3	Nut, Lock; 1/2-13 Washer Insert
16	419456	2	Nut, Lock; 7/16-14 Washer Insert Hex
17	21148	1	Block Bearing Support
18	21147	1	Bearing, Spherical
19	180149	2	Bolt, Hex; 7/16-14 x 1-1/2
20	21071	2	Weldment, Steering Arm
21	446470	2	Washer, Flat; .375 x 1.125 x .065
22	456004	2	Nut, Lock; 3/8-16 Washer Insert Hex
23	14998	2	Race, Bearing Thrust; .752 x 1.240 x .095
24	21079	1	Plate, Adjustment
25	21077	2	Bearing, Flange (P/M Bronze)
26	21076	2	Bushing; .391 x .622 x .670
27	21078	2	Sleeve, Pivot
28	443734	2	Bolt, Hex; 1/2-13 x 6
29	419455	2	Nut, Lock; 5/16-18 Washer Insert Hex
30	454473	2	Screw, Cap; 3/8-16 x 2 Hex Socket HD
31	21075	1	Gear, Rack
32	24442	1	Shaft, Steering Wheel
33	20273	1	Ring, Retaining; Int. Tooth 1.000 Shaft
34	10174	2	Bushing, Nylon; .760 x 1.000 x .600 Flange
35	23376	1	Insert, Steering Wheel
36	24490	1	Wheel, Steering
37	120376	2	Nut, Hex; 5/16-18
38	21246	1	Strap, Rack and Pinion
39	18785	2	Cap, Front Axle
40	24438	1	Bushing, Steering Wheel
41	131016	1	Washer, Flat; .656 x 1.312 x .095
42	418692	1	Nut, Lock; 5/8-11 Washer Insert Hex

# TRANSMISSION CONTROLS AND BRAKE LEVER CONTROLS

f

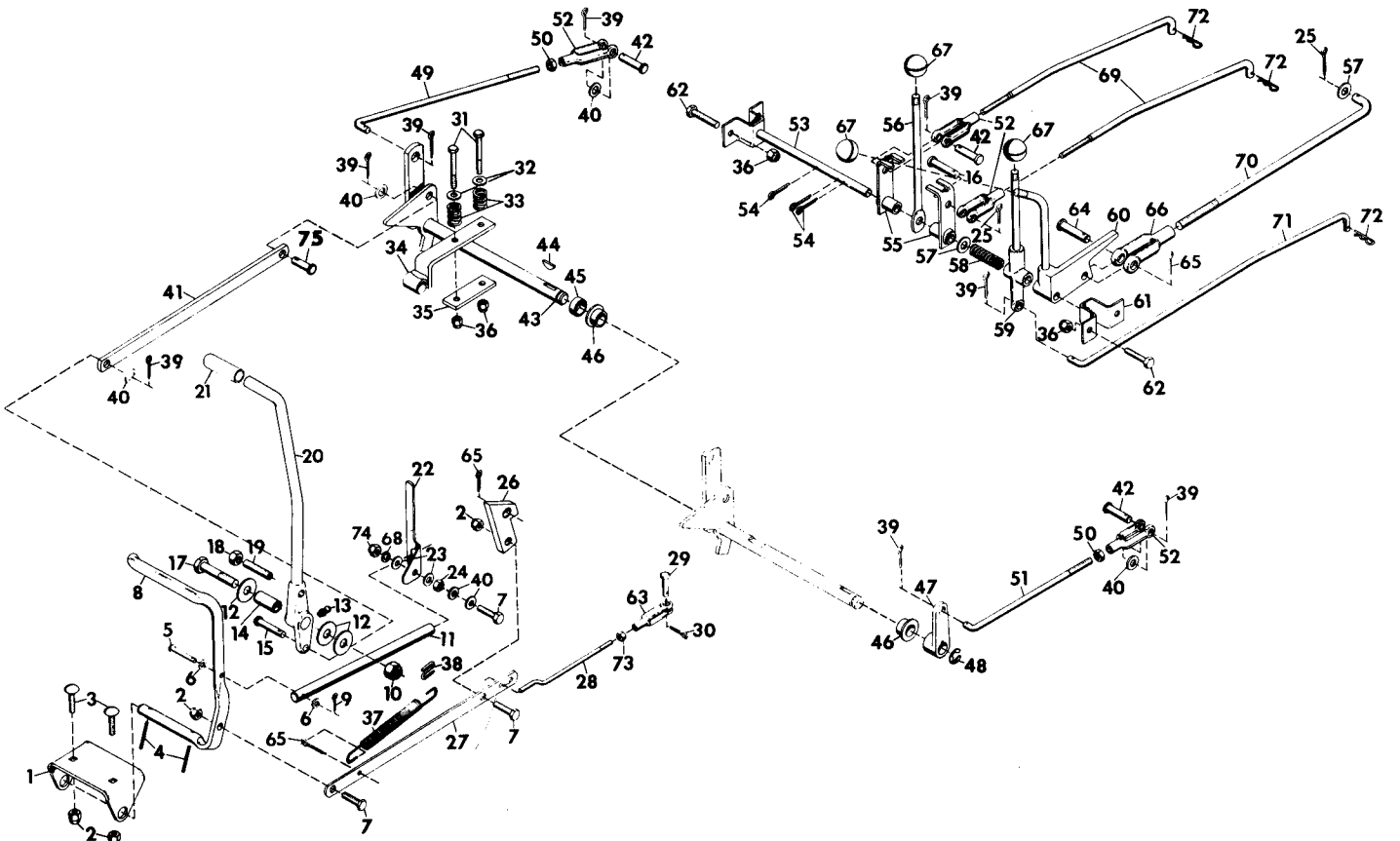
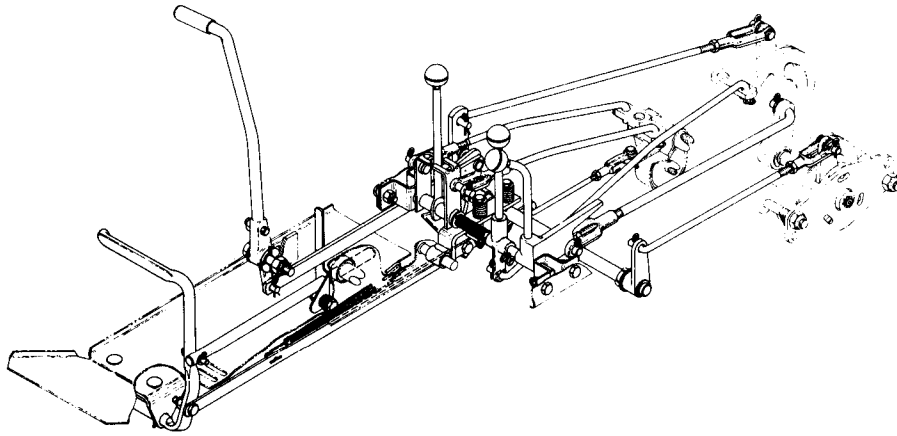

<u>Item No.</u>	<u>Part No.</u>	<u>Qty.</u>	<u>Description</u>
1	11021	1	Bracket, Brake Pedal
2	456004	4	Nut, Lock; 3/8-16 Washer Insert Hex
3	126227	2	Bolt; 3/8-16 x 3/4 RD HD SQ NK
4	454668	2	Pin, Spring; 3/16 x 1-1/4 Cap
5	417923	1	Pin, Clevis; .250 x 1.500
6	120392	2	Washer, Flat; .281 x .625 x .065
7	180124	3	Bolt, Hex; 3/8-16 x 1-1/4
8	11009	1	Pedal, Brake; R.H.
9	121223	1	Pin, Cotter; 1/16 x .75
10	435507	1	Nut, Lock; 1/2-13 Washer Insert
11	20773	1	Rod
12	120390	3	Washer, Flat; 9/16 x 1-3/8 x .109
13	411027	1	Fitting, Lube; 1/4-28
14	11074	1	Bushing; .505 x .74 x 1.438
15	415571	1	Pin, Clevis; .375 x 1.531
16	11718	1	Pin, Clevis; .375 x 1.250
17	180188	1	Bolt, Hex; 1/2-13 x 2-3/4
18	120238	1	Nut, Jam; 1/2-13
19	102623	1	Screw, Set; 1/2-13 x 2 Cup Pt.
20	24450	1	Lever, Forward-Reverse
21	24452	1	Grip, Hand Lever
22	20772	1	Arm, Parking Brake Lock
23	20775	2	Washer, Nylon; .375 x .75 x .060
24	124829	1	Nut, Jam; 3/8-16 Hex
25	179128	1	Pin, Cotter; 1/4 x 1
26	18381	1	Cam, Brake
27	21131	1	Link, Front
28	21132	1	Link, Rear
29	138083	1	Link, Rear
30	423302	1	Pin, Cotter; .078 x .627
31	180091	2	Bolt, Hex; 5/16-18 x 2-1/2
32	120393	2	Washer, Flat; .344 x .688 x .065
33	11779	2	Spring, Comp Type; 1 x .78 x 338 LB/IN
34	18396	1	Bracket, Weldment
35	18464	1	Plate, Clutch Detent
36	419455	6	Nut, Lock; 5/16-18 Washer Insert Hex
37	11263	1	Spring, Ext; 5-1/2 x .50 x 20 Rate
38	11329	1	Clip, Spring
39	121222	6	Pin, Cotter; .09 x .75
40	120394	6	Washer, Flat; .406 x .812 x .065
41	24491	1	Link, Forward-Reverse Shifter
42	138078	2	Pin, Clevis; .395 x .948
43	18390	1	Shaft, Clutch Weldment
44	124552	1	Key, Woodruff; 3/16 x 1 Hard No. 13
45	18485	1	Spacer, .760 x 1.00 x .540
46	10174	1	Bushing, Nylon; .760 x 1.000 x .600 Flange
47	18395	1	Arm, Reverse Clutch
48	11270	1	E-Ring; .750 Shaft
49	18400	1	Rod, Forward Clutch
50	124925	2	Nut, Jam; 3/8-24 Hex
51	18401	1	Rod, Reverse Clutch
52	18380	4	Clevis, 3/8-24 Adjustable
53	18365	1	Shaft, Cross Weldment
54	137185	3	Pin, Cotter; .125 x 1.000
55	18368	2	Arm, Shifter Weldment
56	18371	1	Lever, Shift
57	120396	1	Washer, Flat; .500 x 1.062 x .095
58	18372	1	Spring, Comp Type; 2-3/4 x .625 x 34 Rate
59	18373	1	Control, 2-Speed Asm.
60	20662	1	Control, PTO
61	11096	1	Bracket, Cross Shaft
62	180077	4	Bolt, Hex; 5/16-18 x 3/4
63	104036	1	Clevis, Adjustable; 1/4 x 28
64	138086	1	Pin, Clevis; .500 x 1.213
65	177923	2	Pin, Cotter; .125 x .750
66	18387	1	Yoke, 1/2-20 Adjustable
67	10670	3	Knob, Control
68	120386	1	Washer, Lock; 3/8 SP
69	18389	2	Rod, Shifting
70	18386	1	Rod, PTO
71	18388	1	Rod, 2-Speed
72	11860	3	Cotter, Hair Pin
73	120367	1	Nut, Hex; 1/4-28
74	413534	1	Nut, Lock; 3/8-16 N Hex
75	431780	1	Pin Clevis 3/8 x .750



Item No.	Part No.	Qty.	Description
1	11057	1	Insert, Grille Mesh
2	10969	1	Casting, Grille
3	419455	6	Nut, Lock; 5/16-18 Washer Insert Hex
4	180079	6	Bolt, Hex; 5/16-18 x 1
5	160515	8	Screw, Machine; 1/4-20 x 1/2 Pan HD C-Recess
6	15707	1	Assembly, Hood
	31271		Assembly, Hood Com.
7	18573	1	Tray, Battery
8	180018	5	Bolt, Hex; 1/4-20 x .625
9	419454	12	Nut, Lock; 1/4-20 Washer Insert
10	18197	2	Plug, Bumper
11	11989	1	Decal, Electrical System Warning
12	120392	7	Washer, Flat; .281 x .625 x .065
13	24448	1	Panel, Instrument Homeowner
	24447	1	Panel, Instrument w/Hourmeter
	24446	1	Panel, Instrument w/Ammeter
14	11777	6	Grommet, Plastic
15	180021	7	Bolt, Hex; 1/4-20 x 7/8
16	31164	1	Plate, Control Cover Manual
	31165	1	Plate, Control Cover Hydraulic
	31275	1	Plate, Control Cover Manual Com.
	31276	1	Plate, Control Cover Hydraulic Com.
17	167257	6	Screw, Tapping; 1/4-20 x 1/2 Pan HD C-Recess
18	180124	2	Bolt, Hex; 3/8-16 x 1-1/8
19	24378	2	Strap, Frame Ext.
20	456004	2	Nut, Lock; 3/8-16 Washer Insert Hex
21	24356	2	Spring, Seat
22	24358	2	Bracket, Rear Hitch
23	180175	2	Bolt, Hex; 1/2-13 x 1.25
24	18362	1	Bracket, Fender Hold-Up
25	126216	4	Bolt; 5/16-18 x 3/4 RD HD SQ NK
26	24357	2	Bumper, Seat
27	18420	1	Pin, Clevis; .250 x .500
28	180122	2	Bolt, Hex; 3/8-16 x 1
29	120394	2	Washer, Flat; .406 x .812 x .065
30	24815	2	Bushing, Rear Fender
31	21424	1	Seat, Intermediate Back
	21423	1	Seat, High Back
32	24348	1	Weldment, Seat Pan
	24347	1	Weldment, Seat Pan Onan
33	17837	2	Reflector, Red Safety
34	24608	3	Decal, Gravely Logo
	24588	1	Decal, Gravely Logo
35	121223	1	Pin, Cotter; 1/16 x .75
36	120214	4	Washer, Lock; 5/16 SP
37	18416	1	Strap, Fender Hold-Up
38	22421	1	Bracket, Forward Tank
39	22422	1	Bracket, Rear Tank
40	14897	2	Moulding
41	11058	4	Nut (Rim)
42	24610	1	Stripe, L.H. Side Consumer
	31844	1	Stripe, L.H. & R.H. Side Commercial
NS	24609	1	Stripe, R.H. Side Consumer
43	181700	4	Bolt, Hex; 1/2-20 x 1-1/2
44	24353	1	Weldment, Frame
	31265	1	Weldment, Frame Commercial
45	10405	2	Cotter, Hair Pin
46	180024	2	Bolt, Hex; 1/4-20 x 1-1/4
47	120386	2	Washer, Flat; 5/16 x 47/64 x .065
48	180077	4	Bolt, Hex; 5/16-18 x 3/4
49	180177	2	Bolt, Hex; 1/2-13 x 1-1/2
50	435507	2	Nut, Lock; 1/2-13 Washer Insert
51	446470	4	Washer, Flat; .375 x 1.125 x .065
52	413447	4	Nut, Lock; 5/16-18 Type N Hex
53	24594	2	Decal, Model 8102
	24595	2	Decal, Model 8122
	24596	2	Decal, Model 8123
	24600	2	Decal, Model 8183-T
	31428	2	Decal, Model 8162-B
	31429	2	Decal, Model 8163-B
	24598	2	Decal, Model 8162-T
	24599	2	Decal, Model 8163-T
	31441	2	Decal, Model 8128
	31305	2	Decal, Model 8129
	31442	2	Decal, Model 8169
	31443	2	Decal, Model 8179
	31444	2	Decal, Model 8199
54	12391	1	Assembly, Door
55	24588	1	Decal; Gravely Logo
56	21423	1	Seat, High Back
57	24347	1	Weldment, Seat Pan (Onan)
58	24644	1	Bracket, Fuel Pump
59	180120	2	Bolt, Hex; 3/8-16 x .750
60	24649	1	Pump, Electric Fuel

Circle "A" Pertains to Tractor Model 8179 Only.

**REAR HITCH FOR MODELS  
8102, 8122, 8123, 8128, 8129, 8162-B, 8163-B AND 8169**

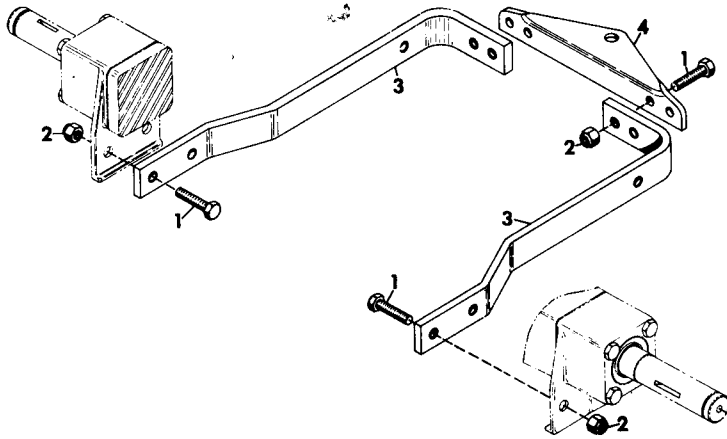

Item No.	Part No.	Qty.	Description
1	180179	8	Bolt, Hex; 1/2-13 x 1-3/4
2	435507	8	Nut, Lock; 1/2-13 Washer Insert
3	20450	2	Arm, Rear Hitch
4	19517	1	Plate, Hitch

**REAR HITCH FOR MODELS  
8162-T, 8183-T, 8163-T, 8179 AND 8199**

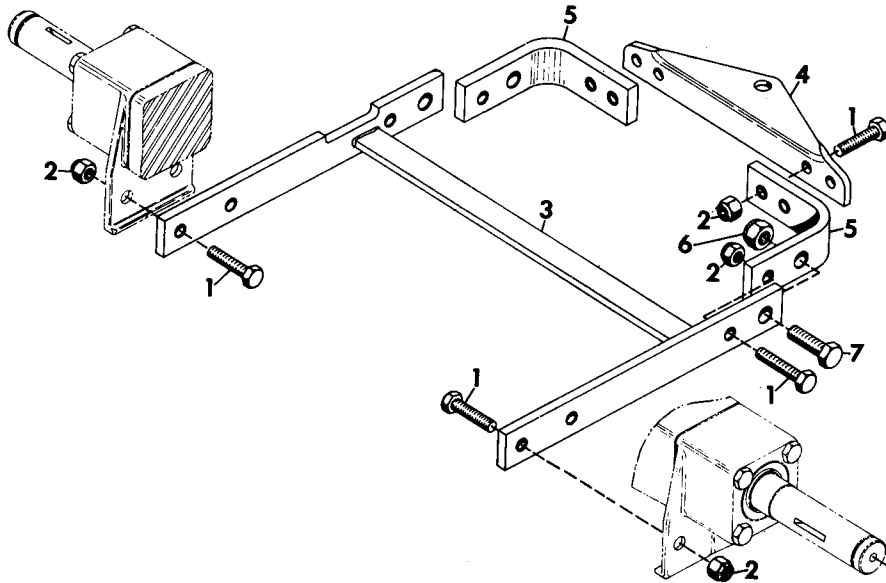

Item No.	Part No.	Qty.	Description
1	180179	10	Bolt, Hex; 1/2-13 x 1-3/4
2	435507	10	Nut, Lock; 1/2-13 Washer Insert
3	21421	1	Weldment, Drawbar 817
4	19517	1	Plate, Hitch
5	21418	2	Bracket, Hitch Plate
6	418692	2	Nut, Lock; 5/8-11 Washer Insert Hex
7	271723	2	Bolt, Hex; 5/8-11 x 2

# ENGINE, FUEL SYSTEM AND EXHAUST SYSTEM FOR MODELS 8102, 8122, 8123, 8128 AND 8129

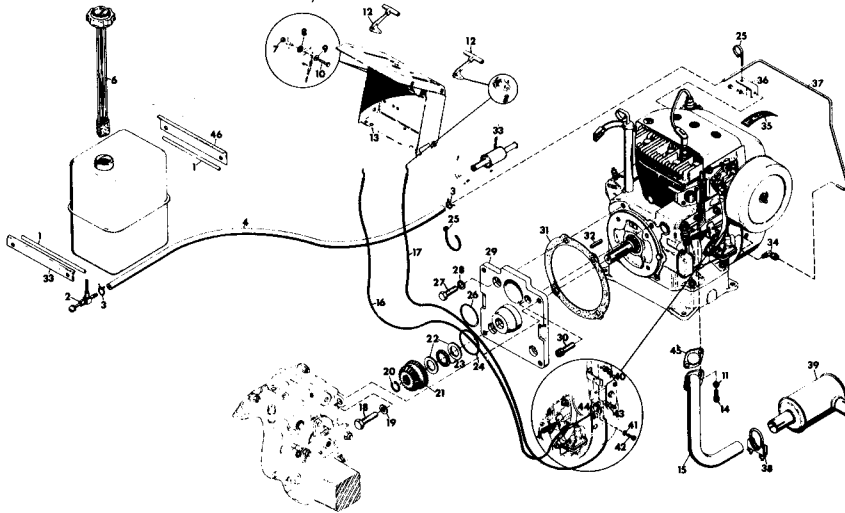

Item No.	Part No.	Qty.	Description
1	14897	2	Moulding
2	18563	1	Valve, Fuel; 90 Deg Reverse Flow
3	7216	2	Clamp, Fuel Hose
4	21482	1	Hose, Fuel
5	12383	1	Tank, Fuel
6	21415	1	Gauge, Gas
7	416430	1	Nut, Lock; 1/4-28 Type N Zinc
8	11772	1	Washer, Friction
9	11774	1	Washer, Spring
10	181566	1	Bolt, Hex; 1/4-28 x 3/4
11	120214	2	Washer, Lock; 5/16 SP
12	11773	2	Assembly, Knob and Lever
13	24446	1	Panel, Instrument w/Ammeter
	24448	1	Panel, Instrument
14	421705	2	Screw, Cap; 5/16-18 x 3/4 Socket HD
15	19492	1	Header, Exhaust
16	18509	1	Assembly, Throttle Conduit 812
17	11771	1	Assembly, Choke Conduit 812
18	180175	4	Bolt, Hex; 1/2-13 x 1.25
19	120396	4	Washer, Flat; .500 x 1.062 x .095
20	18344	1	Ring, Retaining; 1.125 Shaft
21	18343	1	Gear, Spur and Bevel; Input
22	18342	2	Race, Bearing Thrust; 1.127 x 1.740
23	18341	1	Bearing, Thrust; 1.127 x 1.740 x .078
24	18346	1	O-Ring; 3.000 x 3.188 x .094
25	10629	9	Tie, Cable
26	18347	1	O-Ring; 2.500 x 2.750 x .125
27	180146	3	Bolt, Hex; 7/16-14 x 1-1/8
28	131100	3	Washer, Lock; 7/16 SP Heavy
29	20555	1	Adpater, Engine
30	421648	1	Screw, Cap; 7/16-14 x 1 Socket Head
31	18340	1	Gasket, Adaptor
32	18345	1	Key, Square; .250 x 1.250
33	31848	1	Fuel Filter
34	114798	1	Elbow, 1/4 Ball Sleeve Asm.
35	10862	1	Decal, Air Cleaner Instruction
36	12019	1	Bracket, Fuel Line Support
37	12009	1	Connector, to Pump Fuel Line
38	14728	1	Clamp, Muffler
39	18543	1	Muffler, Exhaust
40	7331	1	Clip, Speed
41	120380	1	Washer, Lock; 1/4 SP
42	160515	1	Screw, Mach; 1/4-20 x 1/2 Pan HD
43	120375	1	Nut, Hex; 1/4-20
44	18522	1	Bracket
45	11202	1	Gasket, Exhaust
46	22422	1	Bracket, Rear Tank
47	22421	1	Bracket, Forward Tank



# ENGINE, FUEL SYSTEM AND EXHAUST SYSTEM FOR MODELS 8162-T, 8163-T AND 8183-T

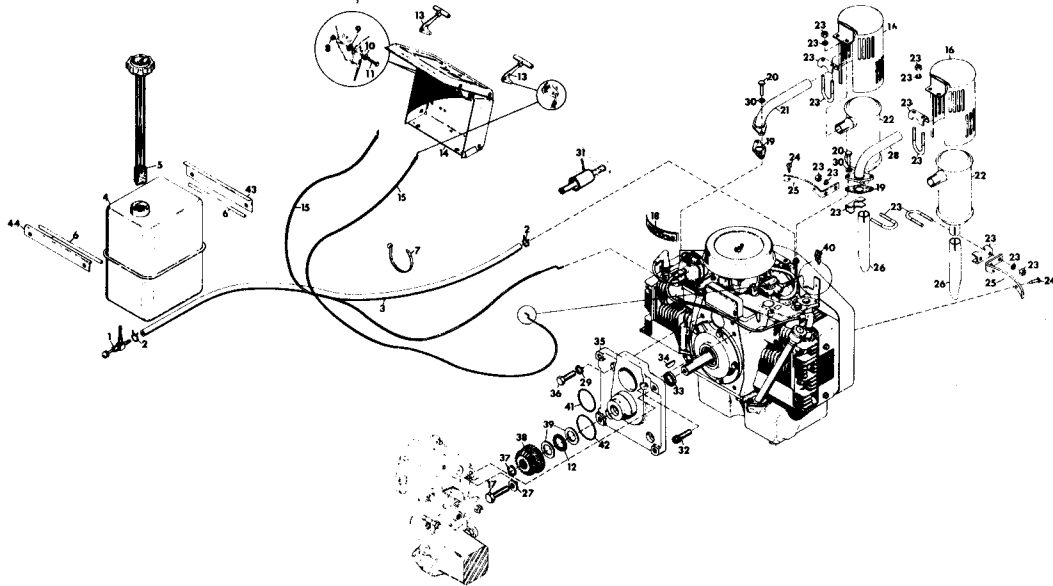

<u>Item No.</u>	<u>Part No.</u>	<u>Qty.</u>	<u>Description</u>
1	18563	1	Valve, Fuel; 90 Deg. Reverse Flow
2	7216	2	Clamp, Fuel Hose
3	20560	1	Hose, Fuel; 67 Inches
4	12383	1	Tank, Fuel
5	21415	1	Gauge, Gas
6	14897	2	Moulding -
7	10629	8	Tie, Cable
8	416430	1	Nut, Lock; 1/4-28 Type N Zinc
9	11772	1	Washer, Friction
10	11774	1	Washer, Spring
11	181566	1	Bolt, Hex; 1/4-28 x 3/4
12	18341	1	Bearing, Thrust; 1.127 x 1.740 x .078
13	11773	2	Assembly, Knob and Lever
14	24447	1	Panel, Instrument w/Hourmeter
15	20565	2	Assembly, Choke Conduit
16	23300	2	Shield, Muffler
17	180177	4	Bolt, Hex; 1/2-13 x 1-1/2
18	10862	1	Decal, Air Cleaner Instruction
19	23290	2	Gasket, Exhaust; Onan
20	421705	4	Screw, Cap; 5/16-18 x 3/4 Socket HD
21	23279	1	Weldment, Exhaust Header R.H.
22	23299	2	Muffler
23	14728	4	Clamp, Muffler
24	144811	4	Screw, Tapping; 10-12 x 1/2 Pan HD C-Recess
25	23280	2	Bracket, Muffler
26	23301	2	Extension, Muffler
27	120396	4	Washer, Flat; .500 x 1.062 x .095
28	23277	1	Weldment, Exhaust Header L.H.
29	120382	3	Washer, Lock; 3/8 SP
30	120214	4	Washer, Lock; 5/16 SP
31	31848	1	Fuel Filter
32	454475	1	Screw, Cap; 3/8-16 x 1-3/4 Hex Socket HD
33	18517	1	Seal, Oil; 1.125 x 1.628 x .250
34	103909	1	Key, Woodruff; .250 x 1.125 Soft
35	18427	1	Adaptor, Engine (Onan NB CCK Engine)
36	180128	3	Bolt, Hex; 3/8-16 x 1-3/4
37	18344	1	Ring, Retaining; 1.125 Shaft
38	18343	1	Gear, Spur and Bevel, Input
39	18342	2	Race, Bearing Thrust; 1.127 x 1.740 x .060
40	7331	1	Clip, Speed
41	18347	1	O-Ring; 2.500 x 2.75 x .125
42	18346	1	O-Ring; 3.000 x 3.188 x .094
43	22422	1	Bracket, Rear Tank
44	22421	1	Bracket, Forward Tank

# ENGINE, FUEL SYSTEM AND EXHAUST SYSTEM FOR MODELS 8162-B, 8163-B AND 8169

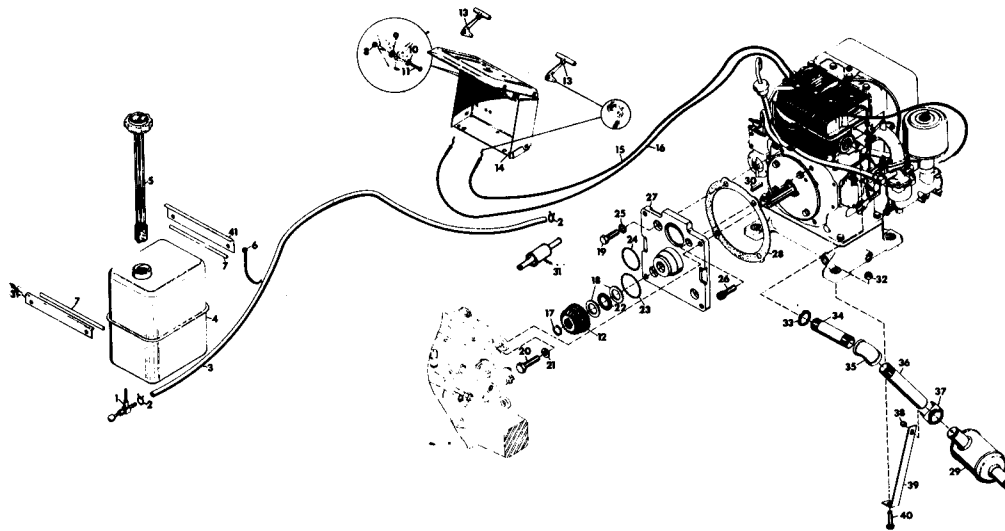

Item No.	Part No.	Qty.	Description
1	18563	1	Valve, Fuel; 90 Deg Reverse Flow
2	7216	2	Clamp, Fuel Hose
3	20560	1	Hose, Fuel; 67 Inches
4	12383	1	Tank, Fuel
5	21415	1	Gauge, Gas
6	10629	12	Tie, Cable
7	14897	2	Moulding
8	416430	1	Nut, Lock; 1/4-28 Type N Zinc
9	11772	1	Washer, Friction
10	11774	1	Washer, Spring
11	181566	1	Bolt, Hex; 1/4-28 x 3/4
12	18343	1	Gear, Spur and Bevel, Input
13	11773	2	Assembly, Knob and Lever
14	24447	1	Panel, Instrument w/Hourmeter
	24448	1	Panel, Instrument
15	20565	1	Assembly, Choke Conduit 816S
16	20942	1	Assembly, Throttle Conduit 816S
17	18344	1	Ring, Retaining; 1.125 Shaft
18	18342	1	Race, Bearing Thrust; 1.127 x 1.740 x .060
19	180146	3	Bolt, Hex; 7/16-14 x 1-1/8
20	180175	4	Bolt, Hex; 1/2-13 x 1.25
21	120396	4	Washer, Flat; .500 x 1.062 x .095
22	18341	1	Bearing, Thrust; 1.127 x 1.740 x .078
23	18346	1	O-Ring; 3.000 x 3.188 x .094
24	18347	1	O-Ring; 2.500 x 2.750 x .125
25	131100	3	Washer, Lock; 7/16 SP Heavy
26	421648	1	Screw, Cap; 7/16-14 x 1 Socket Head
27	20555	1	Adaptor, Engine
28	18340	1	Gasket, Adaptor
29	18543	1	Muffler, Exh
30	18345	1	Key, Square; .250 x 1.250
31	31848	1	Fuel Filter
32	456004	1	Nut, Lock; 3/8-16 Washer Insert Hex
33	10866	1	Nut, Conduit 1" Pipe
34	20579	1	Nipple, Pipe 1 x 6
35	127793	1	Pipe, 1 In. Elbow
36	20580	1	Nipple, Pipe; 1" x 8.4" Special
37	14728	1	Clamp, Muffler
38	120368	1	Nut, Hex; 5/16-24
39	20581	1	Support, Exhaust
40	180124	1	Bolt, Hex; 3/8-16 x 1-1/4
41	22422	1	Bracket, Rear Tank
42	22421	1	Bracket, Forward Tank

# ENGINE, FUEL SYSTEM AND EXHAUST SYSTEM FOR MODEL 8199

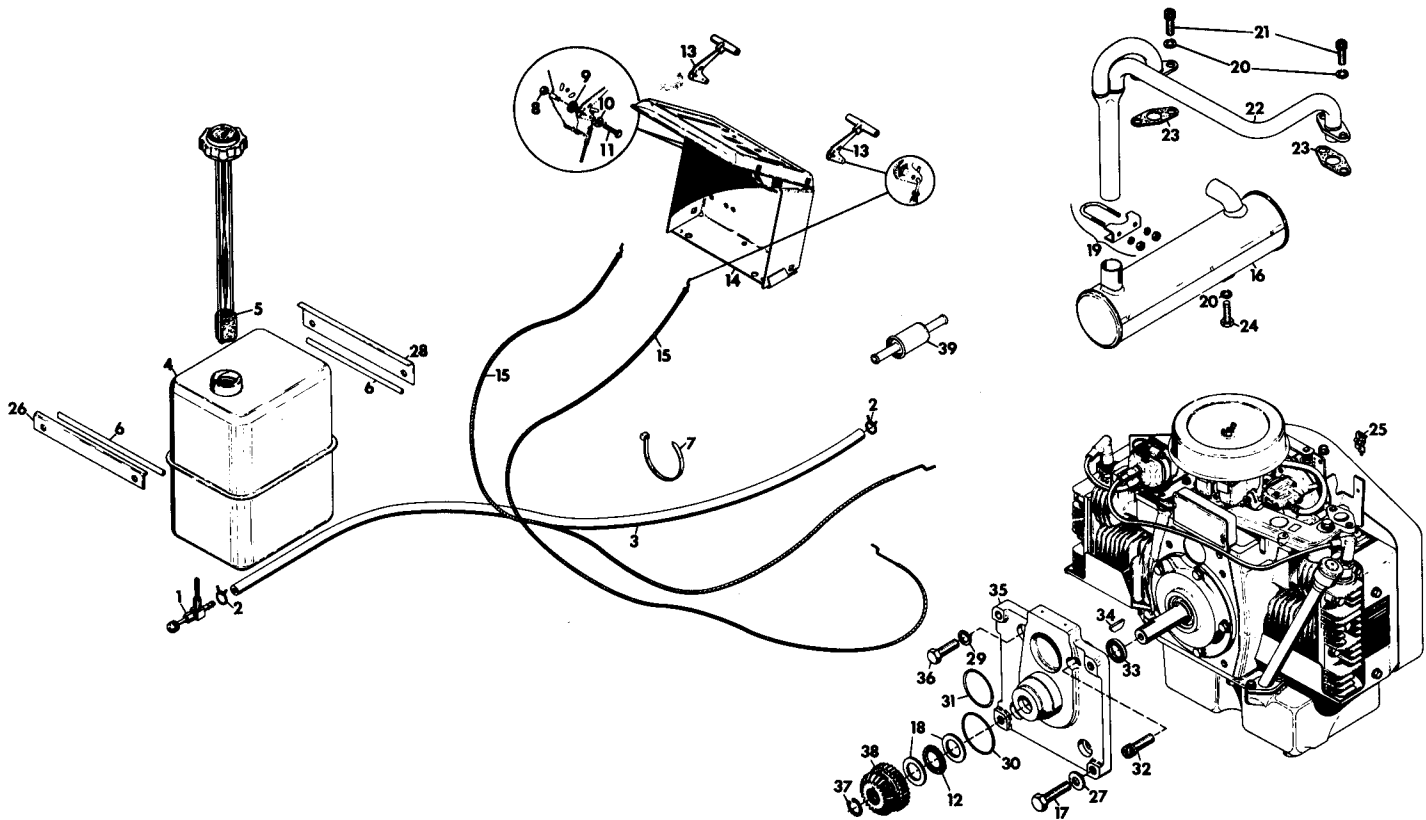

Item No.	Part No.	Qty.	Description
1	18563	1	Valve, Fuel; 90 Deg Reverse Flow
2	7216	4	Clamp, Fuel Hose
3	31447	1	Fuel Hose
4	12383	1	Tank, Fuel
5	21415	1	Gauge, Gas
6	14897	2	Moulding
7	10629	8	Tie, Cable
8	416430	1	Nut, Lock; 1/4-28 Type N Zinc
9	11772	1	Washer, Friction
10	11774	1	Washer, Spring
11	181566	1	Bolt, Hex; 1/4-28 x 3/4
12	18341	1	Bearing, Thrust; 1.127 x 1.740 x .078
13	11773	2	Assembly, Knob and Lever
14	24446	1	Panel, Instrument w/Ammeter
15	20565	2	Assembly, Choke Conduit
16	31719	1	Muffler, Exhaust
17	18344	1	Ring, Retaining; 1.125 Shaft
18	18342	2	Gear, Spur and Bevel Input
19	31720	1	Clamp, Muffler
20	120214	5	Washer, Lock 5/16 Reg
21	421705	4	Screw, Cap; 5/16-18 x 3/4 Socket HD
22	31718	1	Header, Exhaust
23	23290	2	Gasket, Exhaust Onan
24	180079	1	Bolt, Hex; 5/16-18 x 1-1/8
25	7331	1	Clip Speed
26	22421	1	Bracket, Forward Tank
27	120396	4	Washer, Flat; .531 x 1.062 x .095
28	22422	1	Bracket, Rear Tank
29	120382	2	Washer, Lock; 3/8 SP
30	18346	1	O-Ring; 3.000 x 3.188 x .094
31	18347	1	O-Ring; 2.500 x 2.750 x .125
32	454475	1	Screw, Cap; 3/8-16 x 1-3/4 Hex Socket HD
33	18517	1	Seal, Oil; 1.125 x 1.628 x .250
34	103909	1	Key, Woodruff; .250 x 1.125 Soft
35	18427	1	Adaptor, Engine (Onan NB CCK Engine)
36	180128	3	Bolt, Hex 3/8-16 x 1.75
37	18344	1	Ring, Retaining; 1.125 Shaft
38	18343	1	Gear, Spur and Bevel, Input
39	31848	1	Fuel Filter

# ENGINE, FUEL SYSTEM AND EXHAUST SYSTEM FOR MODELS 8179

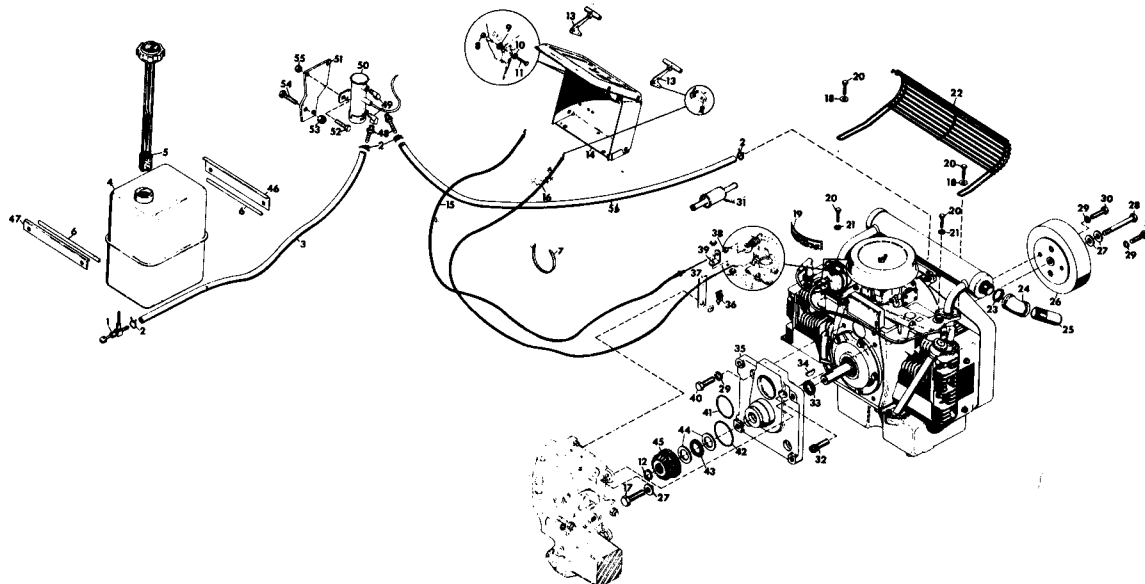

Item No.	Part No.	Qty.	Description
1	18563	1	Valve, Fuel; 900EG Reverse Flow
2	7216	2	Clamp, Fuel Hose
3	23313	1	Hose, Fuel; 66 In.
4	12383	1	Tank, Fuel
5	21415	1	Gauge, Gas
6	14897	2	Moulding
7	10629	8	Tie, Cable
8	416430	1	Nut, Lock; 1/4-28 Type N Zinc
9	11772	1	Washer, Friction
10	11774	1	Washer, Spring
11	181566	1	Bolt, Hex; 1/4-28 x 3/4
12	18344	1	Ring, Retaining; 1.125 Shaft
13	11773	2	Assembly, Knob and Lever
14	24446	1	Assembly, Instrument Panel 8177
15	15752	1	Control
16	19689	1	Assembly, Conduit
17	180177	4	Bolt, Hex; 1/2-13 x 1-1/2
18	446354	2	Washer, Flat; 5/16 x 7/8 x .065
19	10862	1	Decal, Air Cleaner Instruction
20	180079	4	Bolt, Hex; 5/16-18 x 1
21	120214	4	Washer, Lock; 5/16 SP
22	21413	1	Shield, Muffler
23	10866	1	Nut, Conduit 1" Pipe
24	144138	1	Elbow, Pipe 1 In. 45 Deg.
25	19347	1	Pipe, Exhaust
26	19599	1	Flywheel, Aux. Model 816
27	120396	1	Washer, Flat; .500 x 1.062 x .095
28	19598	1	Bolt, Special; 7/16-14 x 5
29	120382	2	Washer, Lock; 3/8 SP
30	180124	2	Bolt, Hex; 3/8-16 x 1-1/4
31	31848	1	Fuel Filter;
32	454475	1	Screw, Cap; 3/8-16 x 1-3/4 Hex Socket HD
33	18517	1	Seal, Oil; 1.125 x 1.628 x .250
34	103909	1	Key, Woodruff; .250 x 1.125 Soft
35	18427	1	Adaptor, Engine (Onan NB CCK Engine)
36	7331	1	Clip, Speed
37	19690	1	Bracket, Control Cable
38	120375	1	Nut, Lock; 1/4-20
39	18522	1	Bracket
40	180128	3	Bolt, Hex; 3/8-16 x 1-3/4
41	18347	1	O-Ring; 2.500 x 2.750 x .125
42	18346	1	O-Ring; 3.000 x 3.188 x .094
43	18341	1	Bearing, Thrust; 1.127 x 1.740 x .078
44	18342	2	Race, Bearing Thrust; 1.127 x 1.740 x .060
45	18343	1	Gear, Spur and Bevel, Input
46	22422	1	Bracket, Rear Tank
47	22421	1	Bracket, Forward Tank
48	13502	2	Connector
49	24648	2	Fitting, Fuel Pump 900 Elbow
50	24649	1	Pump, Electric Fuel
51	24644	1	Bracket, Fuel Pump
52	180020	2	Bolt, Hex; 1/4-20 x 3/4
53	456004	2	Nut, Lock; 3/8-16 Washer Insert Hex
54	180120	2	Bolt, Hex; 3/8-16 x .750
55	419454	2	Nut, Lock; 1/4-20 Washer Insert
56	24645	1	Hose, Fuel Pump Inlet

# ELECTRIC SYSTEM FOR MODELS 8122 AND 8123

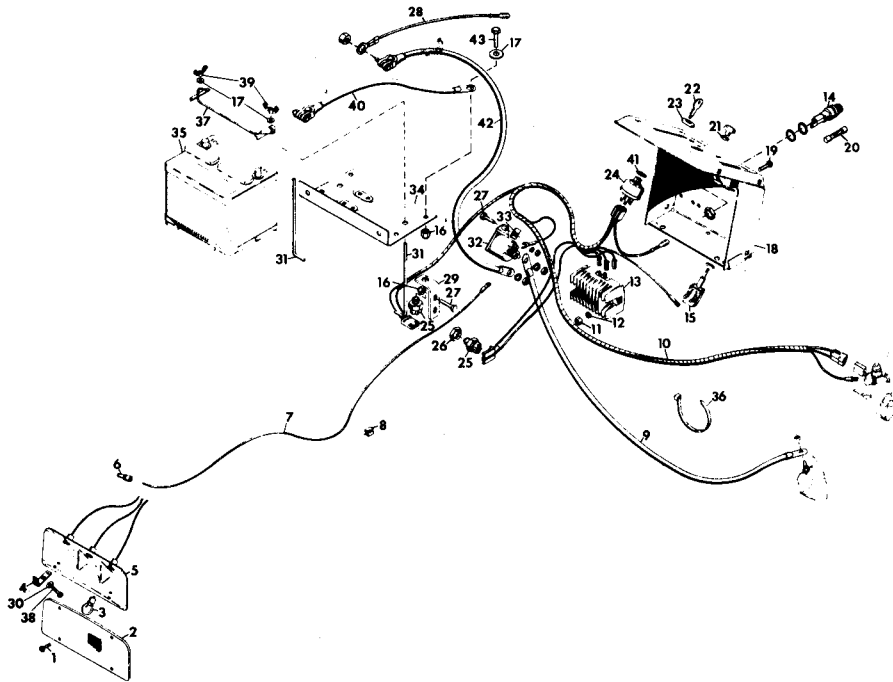

Item No.	Part No.	Qty.	Description
1	159920	4	Screw, Mach; 10-24 x 1/2 Pan HD C-Recess
2	11289	1	Panel, Front Light
3	454646	3	Lamp; No. 1073
4	11030	4	Clip, Light Mtg.
5	11334	1	Assembly, Lamp Reflector
6	11763	1	Nut, Wire
7	19534	1	Wire, Headlight
8	11286	2	Clip, Wire
9	11031	1	Cable, Starter
10	22122	1	Harness, Wiring; 810 & 812
11	120375	2	Nut, Hex; 1/4-20
12	120380	2	Washer, Lock; 1/4 SP
13	18009	1	Regulator, Rectifier
14	21416	1	Fuse, Panel
15	11337	1	Switch, Light
16	419454	2	Nut, Lock; 1/4-20 Washer Insert
17	120392	3	Washer, Flat; .281 x .625 x .065
18	24448	1	Panel Instrument Consumer
19	160541	2	Screw, Machine; 1/4-20 Pan HD
20	14893	1	Fuse, 30 Amp Acc-30
21	18587	1	Nut, Special; Light Switch
22	18570	1	Key, Ignition Switch
23	19666	1	Nut, Jam; 9/16-24 Indak 83024
24	19223	1	Switch, Ignition Indak J463-A
25	20916	2	Switch, Interlock
26	107354	1	Nut, Stamped; 9/16-18
27	180018	2	Bolt, Hex; 1/4-20 x .625
28	21425	1	Wire, Instrument Panel
29	20660	1	Bracket, Switch
30	120385	4	Washer, Flat; .188 x .562 x .049
31	12386	2	Hook, Battery
32	7277	1	Switch, Mag; Delco 1466, Prestolite EO17811
33	11676	1	Nut, Speed; 1/4-20
34	18573	1	Tray, Battery
35	7274	1	Battery, 12V
36	10629	9	Tie, Cable
37	11027	1	Bracket, Battery Hold Down
38	159947	4	Screw, Mach; 10-24 x 3/4 Pan HD C-Recess
39	10413	2	Nut, Wing; 1/4-20 Washer Insert
40	6980	1	Cable, Negative Battery
41	19667	1	Washer, Lock; 9/16 Int Tooth, Indak 85013
42	12375	1	Cable, Battery to Magnetic Switch
43	180021	1	Bolt, Hex; 1/4-20 x 7/8

# ELECTRIC SYSTEM FOR MODEL 8102

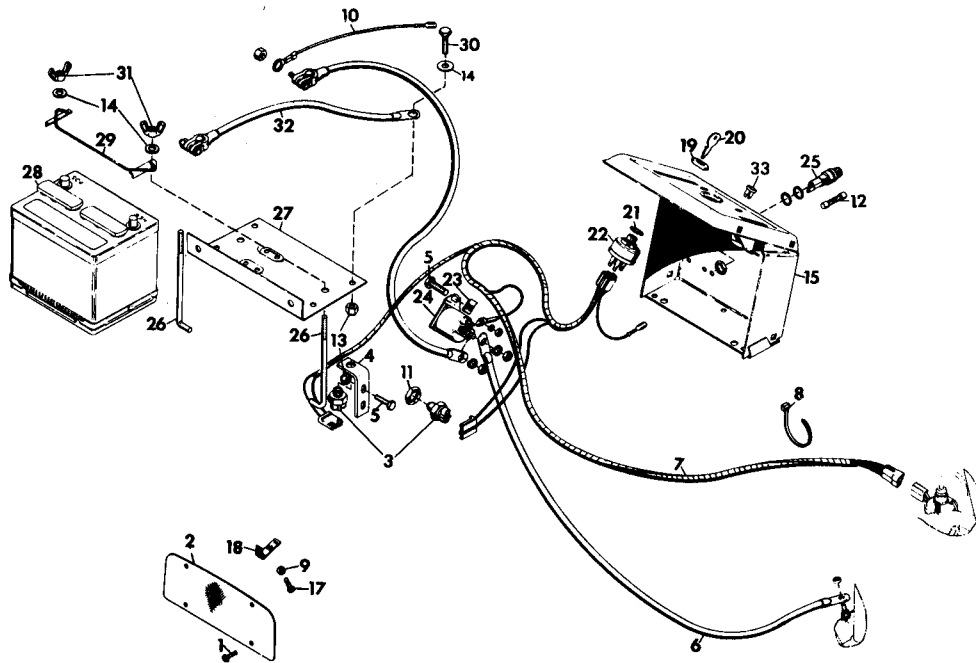

Item No.	Part No.	Qty.	Description
1	159920	4	Screw, Mach; 10-24 x 1/2 Pan HD C-Recess
2	11288	1	Panel, Front
3	20916	2	Switch, Interlock
4	20660	1	Bracket, Switch
5	180018	3	Bolt, Hex; 1/4-20 x .625
6	11031	1	Cable, Starter
7	24754	1	Harness, Wiring 3 Amp
8	10629	9	Tie, Cable
9	120385	4	Washer, Flat; .188 x .562 x .049
10	21425	1	Wire Instrument Panel
11	107354	1	Nut, Stamped; 9/16-18
12	24858	1	Fuse, 5 Amp 3 AG5
13	419454	3	Nut, Lock; 1/4-20 Washer Insert
14	120392	2	Washer, Flat; .281 x .625 x .065
15	24448	1	Panel, Instrument Homeowner
16	12375	1	Cable, Battery to Magnetic Switch
17	159947	4	Screw, Mach; 10-24 x 3/4 Pan HD C-Recess
18	11030	4	Clip, Light Mtg.
19	19666	1	Nut, Jam; 9/16-24 Indak 83024
20	18570	1	Key, Ignition Switch
21	19667	1	Washer, Lock; 9/16 Int. Tooth, Indak 85013
22	19223	1	Switch, Ignition Indak J463-A
23	11676	1	Nut, Speed; 1/4-20
24	7277	1	Switch, Mag; Delco 1466, Prestolite EO17811
25	21416	1	Fuse, Panel
26	12386	2	Hook, Battery
27	18573	1	Tray, Battery
28	7274	1	Battery, 12V
29	11027	1	Bracket, Battery Hold Down
30	180021	1	Bolt, Hex; 1/4-20 x 7/8
31	10413	2	Nut, Wing; 1/4-20 Washer Inert
32	6980	1	Cable, Negative Battery
33	24449	1	Plug, Button (Light Switch)

# ELECTRIC SYSTEM FOR MODELS 8128 AND 8129

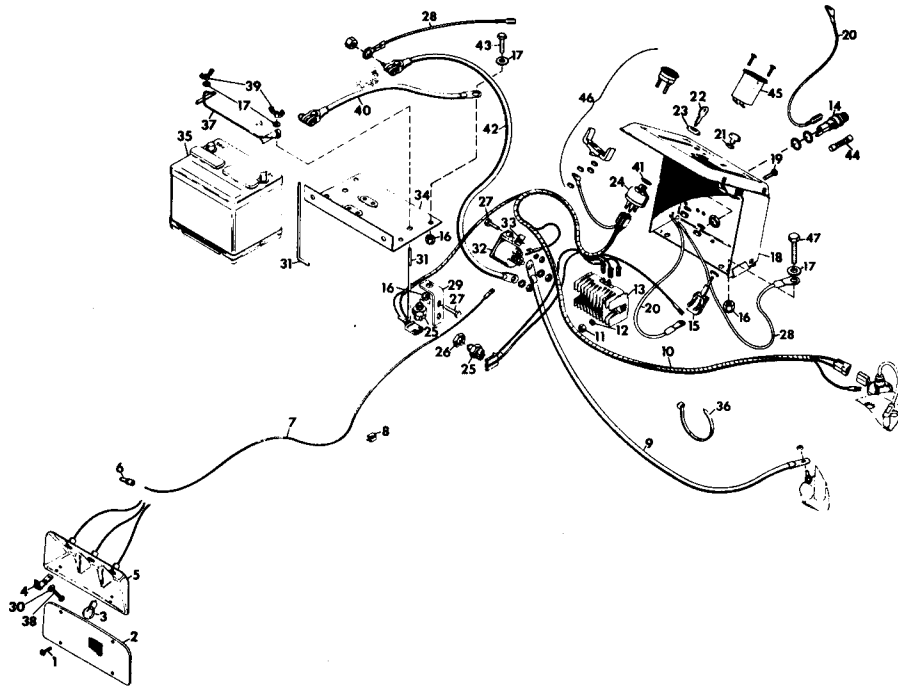

Item No.	Part No.	Qty.	Description
1	159920	4	Screw, Mach; 10-24 x 1/2 Pan HD C-Recess
2	11289	1	Panel, Front Light
3	454646	3	Lamp; No. 1073
4	11030	4	Clip, Light Mtg.
5	11334	1	Assembly, Lamp Reflector
6	11763	1	Nut, Wire
7	19534	1	Wire, Headlight
8	11286	2	Clip, Wire
9	11031	1	Cable, Starter
10	22122	1	Harness, Wiring; 810 & 812
11	120375	2	Nut, Hex; 1/4-20
12	120380	2	Washer, Lock; 1/4 SP
13	18009	1	Regulator, Rectifier
14	21416	1	Fuse, Panel
15	11337	1	Switch, Light
16	419454	3	Nut, Lock; 1/4-20 Washer Insert
17	120392	4	Washer, Flat; .281 x .625 x .065
18	24446	1	Panel, Instrument w/Ammeter
19	160541	2	Screw, Machine; 1/4-20 Pan HD
20	21426	2	Wire, Hourmeter
21	18587	1	Nut, Special; Light Switch
22	18570	1	Key, Ignition Switch
23	19666	1	Nut, Jam; 9/16-24 Indak 83024
24	19223	1	Switch, Ignition Indak 1463-A
25	20916	2	Switch, Interlock
26	107354	1	Nut, Stamped; 9/16-18
27	180018	3	Bolt, Hex; 1/4-20 x .625
28	21425	2	Wire, Instrument Panel
29	20660	1	Bracket, Switch
30	120385	4	Washer, Flat; .188 x .562 x .049
31	12386	2	Hook, Battery
32	7277	1	Switch, Mach; Delco 1466, Prestolite EO17811
33	11676	1	Nut, Speed; 1/4-20
34	18573	1	Tray, Battery
35	7274	1	Battery, 12V
36	10629	9	Tie, Cable
37	11027	1	Bracket, Battery Hold Down
38	159947	4	Screw, Mach; 10-24 x 3/4 Pan HD C-Recess
39	10413	2	Nut, Wing; 1/4-20 Washer Insert
40	6980	1	Cable, Negative Battery
41	19667	1	Washer, Lock; 9/16 Int Tooth, Indak 85013
42	12375	1	Cable, Battery to Magnetic Switch
43	180021	1	Bolt, Hex; 1/4-20 x 7/8
44	14893	1	Fuse, 30 Amp Acc-30
45	21414	1	Hourmeter
46	21848	1	Gauge; Ammeter
47	180020	1	Bolt, Hex; 1/4-20 x 3/4

# ELECTRIC SYSTEM FOR MODELS 8162-T, 8163-T AND 8183-T

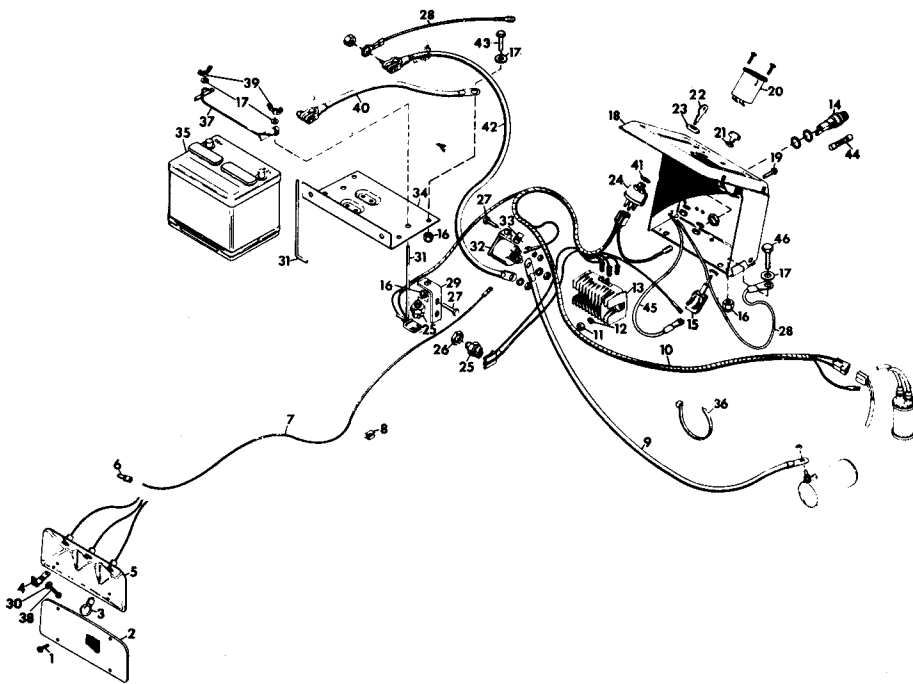

<u>Item No.</u>	<u>Part No.</u>	<u>Qty.</u>	<u>Description</u>
1	159920	4	Screw, Mach; 10-24 x 1/2 Pan HD C-Recess
2	11289	1	Panel, Front Light
3	454646	3	Lamp; No. 1073
4	11030	4	Clip, Light Mtg.
5	11334	1	Assembly, Lamp Reflector
6	11763	1	Nut, Wire
7	19534	1	Wire, Headlight
8	11286	2	Clip, Wire
9	23310	1	Cable, Battery
10	23304	1	Harness, Wiring
11	120375	2	Nut, Hex; 1/4-20
12	120380	2	Washer, Lock; 1/4 SP
13	18009	1	Regulator, Rectifier
14	21416	1	Fuse, Panel
15	11337	1	Switch, Light
16	419454	3	Nut, Lock; 1/4-20 Washer Insert
17	120392	2	Washer, Flat; .281 x .625 x .065
18	24447	1	Panel, Instrument w/Hourmeter
19	160541	2	Screw, Machine; 1/4-20 Pan HD
20	21414	1	Hourmeter
21	18587	1	Nut, Special; Light Switch
22	18570	1	Key, Ignition Switch
23	19666	1	Nut, Jam; 9/16-24 Indak 83024
24	19223	1	Switch, Ignition Indak J463-A
25	20916	2	Switch, Interlock
26	107354	1	Nut, Stamped; 9/16-18
27	180018	3	Bolt, Hex; 1/4-20 x .625
28	21425	1	Wire, Instrument Panel
29	20660	1	Bracket, Switch
30	120385	4	Washer, Flat; .188 x .562 x .049
31	12386	2	Hook, Battery
32	7277	1	Switch, Mach; Delco 1466, Prestolite EO17811
33	11676	1	Nut, Speed; 1/4-20
34	18573	1	Tray, Battery
35	7274	1	Battery, 12V
36	10629	8	Tie, Cable
37	11027	1	Bracket, Battery Hold Down
38	159947	4	Screw, Mach; 10-24 x 3/4 Pan HD C-Recess
39	10413	2	Nut, Wing; 1/4-20 Washer Insert
40	6980	1	Cable, Negative Battery
41	19667	1	Washer, Lock; 9/16 Int Tooth, Indak 85013
42	12375	1	Cable, Battery to Magnetic Switch
43	180021	1	Bolt, Hex; 1/4-20 x 7/8
44	14893	1	Fuse, 30 Amp Acc-30
45	21426	2	Wire, Hourmeter
46	180020	1	Bolt, Hex; 1/4-20 x 3/4



# ELECTRIC SYSTEM FOR MODEL 8169

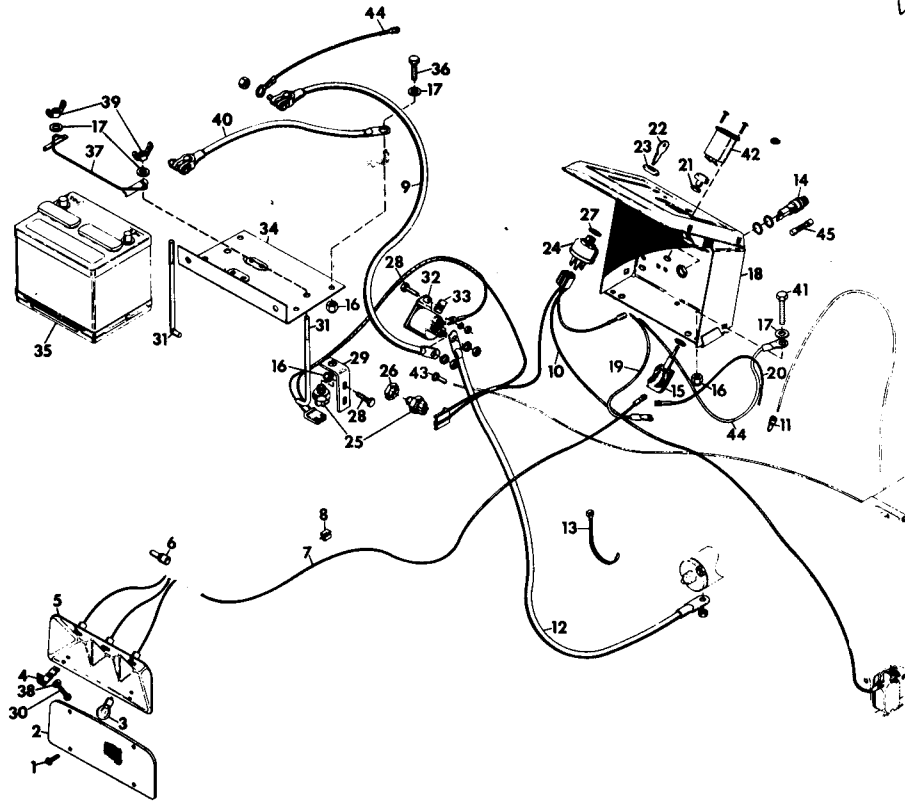

Item No.	Part No.	Qty.	Description
1	159920	4	Screw, Mach; 10-24 x 1/2 Pan HD C-Recess
2	11289	1	Panel, Front Light
3	454646	3	Lamp; No. 1073
4	11030	4	Clip, Light Mtg.
5	11334	1	Assembly, Lamp Reflector
6	11763	1	Nut, Wire
7	19534	1	Wire, Headlight
8	11286	2	Clip, Wire
9	12375	1	Cable, Battery to Magnetic Switch
10	22121	1	Harness, Wiring
11	11763	1	Nut, Wire
12	20577	1	Cable, Starter
13	10629	12	Tie, Cable
14	21416	1	Fuse, Panel
15	11337	1	Switch, Light
16	419454	3	Nut, Lock; 1/4-20 Washer Insert
17	120392	4	Washer, Flat; .281 x .625 x .065
18	24447	1	Panel, Instrument w/Hourmeter
19	23550	1	Wire, Hourmeter
20	20777	1	Wire, Headlights
21	18587	1	Nut, Special; Light Switch
22	18570	1	Key, Ignition Switch
23	19666	1	Nut, Jam; 9/16-24 Indak 83024
24	20564	1	Switch, Ignition Indak D463-A
25	20916	2	Switch, Interlock
26	107354	1	Nut, Stamped; 9/16-18
27	19667	1	Washer, Lock; 9/16 Int Tooth, Indak 85013
28	180018	3	Bolt, Hex; 1/4-20 x .625
29	20660	1	Bracket, Switch
30	159947	4	Screw, Mach; 10-24 x 3/4 Pan HD C-Recess
31	12386	2	Hook, Battery
32	7277	1	Switch, Mag.
33	11676	1	Nut, Speed; 1/4-20
34	18573	1	Tray, Battery
35	7274	1	Battery, 12V
36	180021	1	Bolt, Hex; 1/4-20 x 7/8
37	11027	1	Bracket, Battery Hold Down
38	120385	4	Washer, Flat; .188 x .562 x .049
39	10413	2	Nut, Wing; 1/4-20 Washer Insert
40	6980	1	Cable, Negative Battery
41	180020	1	Bolt, Hex; 1/4-20 x 3/4
42	21414	1	Hourmeter
43	24756	1	Eyelet
44	21425	2	Wire, Instrument Panel
45	14893	1	Fuse, .30 Amp Acc-30

# ELECTRIC SYSTEM FOR MODEL 8199

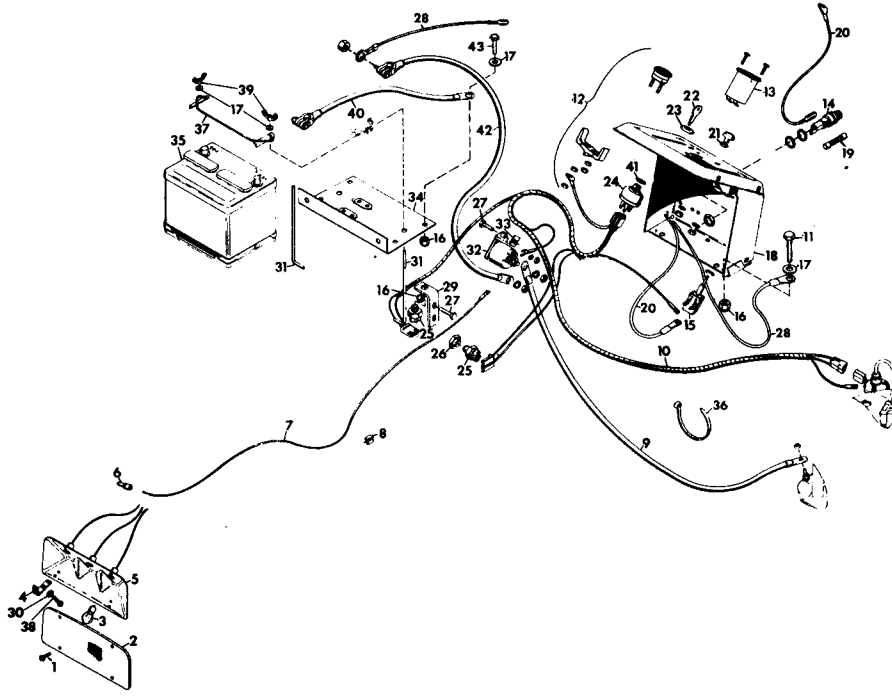

Item No.	Part No.	Qty.	Description
1	159920	4	Screw, Mach; 10-24 x 1/2 Pan HD C-Recess
2	11289	1	Panel, Front Light
3	454646	3	Lamp; No. 1073
4	11030	4	Clip, Light Mtg.
5	11334	1	Assembly, Lamp Reflector
6	11763	1	Nut, Wire
7	19534	1	Wire, Headlight
8	11286	2	Clip, Wire
9	31450	1	Cable, Starter
10	31717	1	Harness, Wiring
11	180020	1	Bolt, Hex; 1/4-20 3/4
12	21848	1	Gauge Ammeter
13	21414	1	Hourmeter
14	21416	1	Fuse, Panel
15	11337	1	Switch, Light
16	419454	3	Nut, Lock; 1/4-20 Washer Insert
17	120392	4	Washer, Flat; .281 x .625 x .065
18	24446	1	Panel, Instrument w/Ammeter
19	14893	1	Fuse, 30 Amp Acc-30
20	21426	2	Wire, Hourmeter
21	18587	1	Nut, Special; light Switch
22	18570	1	Key, Ignition Switch
23	19666	1	Nut, Jam; 9/16-24 Indak 83024
24	19223	1	Switch, Ignition Indak 1463-A
25	20916	2	Switch, Interlock
26	107354	1	Nut, Stamped; 9/16-18
27	180018	3	Bolt, Hex; 1/4-20 x .625
28	21425	2	Wire, Instrument Panel
29	20660	1	Bracket, Switch
30	120385	4	Washer, Flat; .188 x .562 x .049
31	12386	2	Hook, Battery
32	7277	1	Switch, Mach; Delco 1466, Prestolite EO17811
33	11676	1	Nut, Speed; 1/4-20
34	18573	1	Tray, Battery
35	7274	1	Battery, 12V
36	10629	9	Tie, Cable
37	11027	1	Bracket, Battery Hold Down
38	159947	4	Screw, Mach; 10-24 x 3/4 Pan HD C-Recess
39	10413	2	Nut, Wing; 1/4-20 Washer Insert
40	6980	1	Cable, Negative Battery
41	19667	1	Washer, Lock; 9/16 Int Tooth, Indak 85013
42	12375	1	Cable, Battery to Magnetic Switch
43	180021	1	Bolt, Hex; 1/4-20 x 7/8

# ELECTRIC SYSTEM FOR MODEL 8179

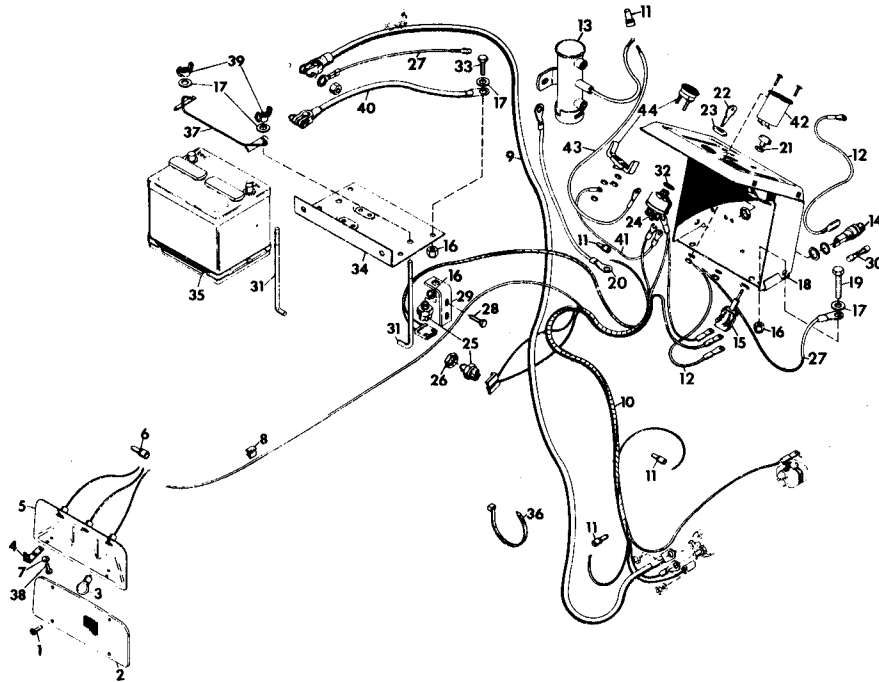

Item No.	Part No.	Qty.	Description
1	159920	4	Screw, Mach; 10-24 x 1/2 Pan HD C-Recess
2	11289	1	Panel, Front Light
3	454646	3	Lamp; No. 1073
4	11030	4	Clip, Light Mtg.
5	11334	1	Assembly, Lamp Reflector
6	11763	1	Nut, Wire
7	120385	4	Washer, Flat; .188 x .562 x .049
8	11286	4	Clip, Wire
9	20889	1	Cable, Battery
10	24755	1	Harness, Wiring T Tractors
11	11763	2	Nut, Wire
12	21426	2	Wire, Hourmeter
13	24649	1	Pump, Electric Fuel
14	21416	1	Fuse, Panel
15	11337	1	Switch, Light
16	419454	4	Nut, Lock; 1/4-20 Washer Insert
17	120392	4	Washer, Flat; .281 x .625 x .065
18	24446	1	Panel, Instrument w/Ammeter
19	180020	1	Bolt, Hex; 1/4-20 x 3/4
20	24647	1	Wire, Fuel Pump Ground
21	18587	1	Nut, Special; Light Switch
22	18570	1	Key, Ignition Switch
23	18585	1	Nut, Jam; 5/8-32
24	18207	1	Switch, Ignition
25	20916	2	Switch, Interlock
26	107354	1	Nut, Stamped; 9/16-18
27	21425	2	Wire, Instrument Panel
28	180018	2	Bolt, Hex; 1/4-20 x .625
29	20660	1	Bracket, Switch
30	14893	1	Fuse, 30 Amp Acc-30
31	12386	2	Hook, Battery
32	18586	1	Washer, Lock; 5/8 Int Tooth
33	180021	1	Bolt, Hex; 1/4-20 x 7/8
34	18573	1	Tray, Battery
35	7274	1	Battery, 12V
36	10629	8	Tie, Cable
37	11027	1	Bracket, Battery Hold Down
38	159947	4	Screw, Mach; 10-24 x 3/4 Pan HD C-Recess
39	10413	2	Nut, Wing; 1/4-20 Washer Insert
40	6980	1	Cable, Negative Battery
41	24769	1	Wire, Amp Meter
42	21414	1	Hourmeter
43	24655	1	Wire, Fuel Pump
44	21848	1	Gauge, Ammeter

# ELECTRIC SYSTEM FOR MODELS 8162-B AND 8163-B

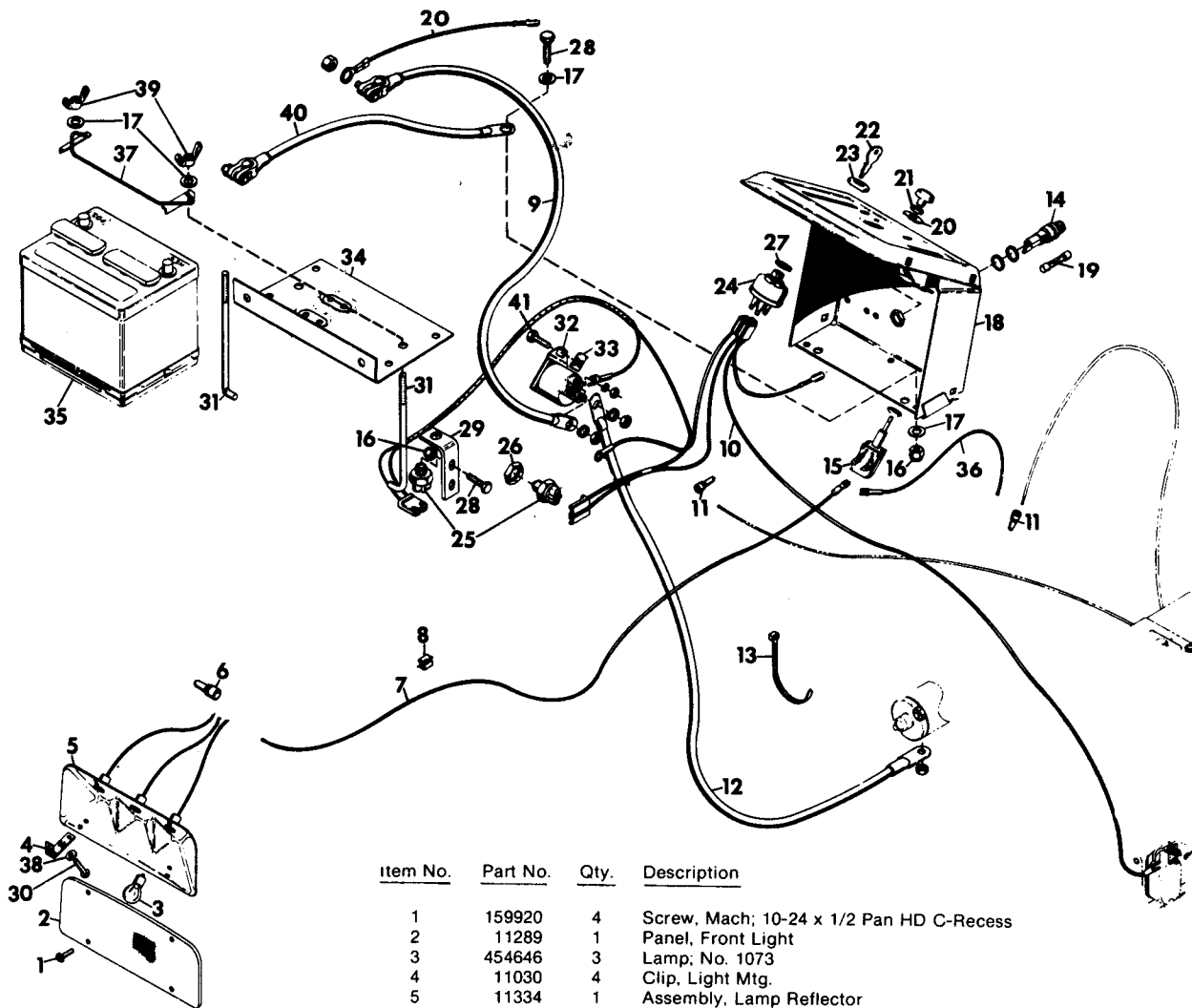

Item No.	Part No.	Qty.	Description
1	159920	4	Screw, Mach; 10-24 x 1/2 Pan HD C-Recess
2	11289	1	Panel, Front Light
3	454646	3	Lamp; No. 1073
4	11030	4	Clip, Light Mtg.
5	11334	1	Assembly, Lamp Reflector
6	11763	1	Nut, Wire
7	19534	1	Wire, Headlights
8	11286	4	Clip, Wire
9	12375	1	Cable, Battery to Magnetic Switch
10	22121	1	Harness, Wiring
11	11763	1	Nut, Wire
12	20577	1	Cable, Starter
13	10629	6	Tie, Cable
14	21416	1	Fuse, Panel
15	11337	1	Switch, Light
16	419454	3	Nut, Lock; 1/4-20 Washer Insert
17	120392	4	Washer, Flat; .281 x .625 x .065
18	24448	1	Panel, Instrument Consumer
19	14893	1	Fuse, 30 Amp Acc-30
20	21425	2	Wire, Instrument Panel
21	18587	1	Nut, Special
22	18570	1	Key, Ignition Switch
23	19666	1	Nut, Jam; 9/16-24
24	20564	1	Switch, Ignition
25	20916	2	Switch, Interlock
26	107354	1	Nut, Stamped; 9/16-18 x 7/8
27	19667	1	Washer, Lock Int Tooth
28	180021	3	Bolt, Hex; 1/4-20 x 7/8
29	20660	1	Bracket, Switch
30	159947	4	Screw, Mach. 10-24 Pan HD
31	12386	2	Hook, Battery
32	2777	1	Switch, Magnetic
33	11676	1	Nut, Speed; 1/4-20
34	18573	1	Tray, Battery
35	7274	1	Battery, 12V
36	20777	1	Wire, Headlight
37	11027	1	Bracket, Battery Hold Down
38	120385	4	Washer, Flat; 3/16 x 9/16 x .049
39	10413	2	Nut, Wing; 1/4-20 Washer Insert
40	6980	1	Cable, Negative Battery

# FRONT AND REAR WHEEL

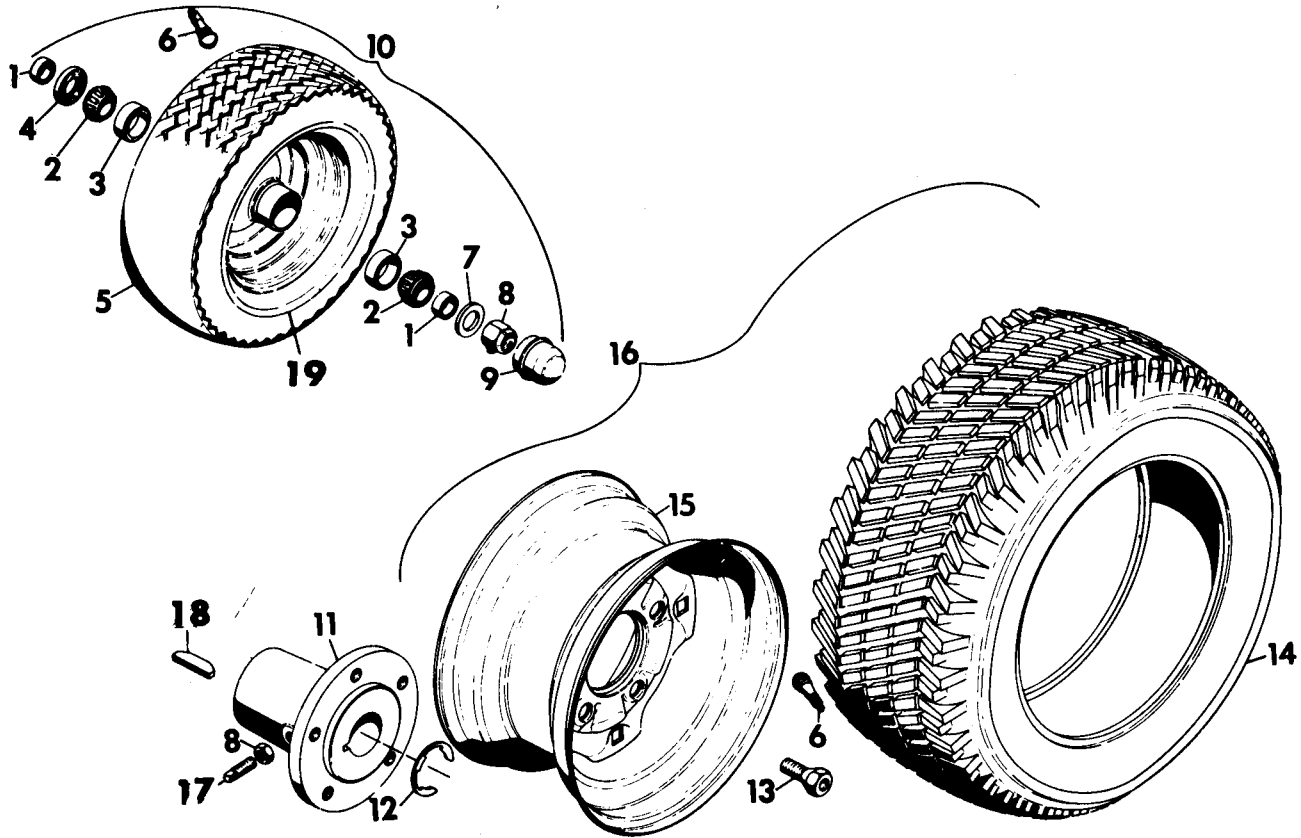

Item No.	Part No.	Qty.	Description
1	18448	2	Spacer
2	18446	2	Bearing, Cone
3	18445	2	Bearing, Cup LM 11910
4	18447	1	Seal
5	11190	1	Tire, Front; 16 x 6.50-8
	31280	1	Tire, Front; 16 x 7.50-8
6	11191	2	Assembly, Valve Stem
7	131016	1	Washer, Flat; .656 x 1.312 x .095
8	418692	1	Nut, Lock; 5/8-11 Washer Insert Hex
9	18449	1	Cap
10	18442	1	Assembly, Front Wheel 16 x 6.50-8
	31425	1	Assembly, Front Wheel 16 x 7.50-8
11	18052	1	Hub, Wheel
12	18055	1	E-Ring; 1.125 Shaft
13	12744	5	Bolts, Hub; 7/16-20 x 3/4 (Special)
14	11194	1	Tire, Rear; 23 x 8.50-12
	31278	1	Tire, Rear; 23 x 10.50-12
15	11195	1	Rim, Weldment
16	11705	1	Assembly, Rear Wheel 23 x 8.50-12
	31424	1	Assembly, Rear Wheel 23 x 10.50-12
17	102897	1	Screw Set 3/8-16 x 1-1/4 SQ HD Cup
18	187184	1	Key, Woodruff; .250 x 2.125 Soft Point
19	18443	1	Rim, Front Wheel Assm.

## WIRING DIAGRAM FOR 8102

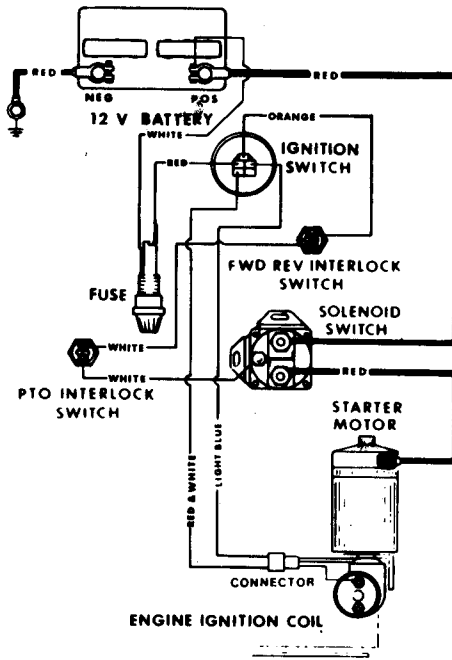

## WIRING DIAGRAM FOR 8122 AND 8123

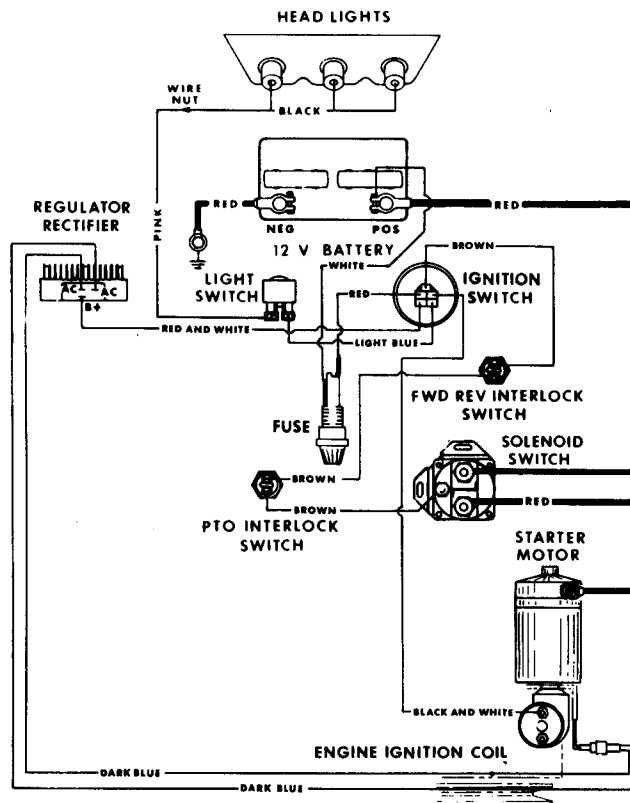

## WIRING DIAGRAM FOR 8128 AND 8129

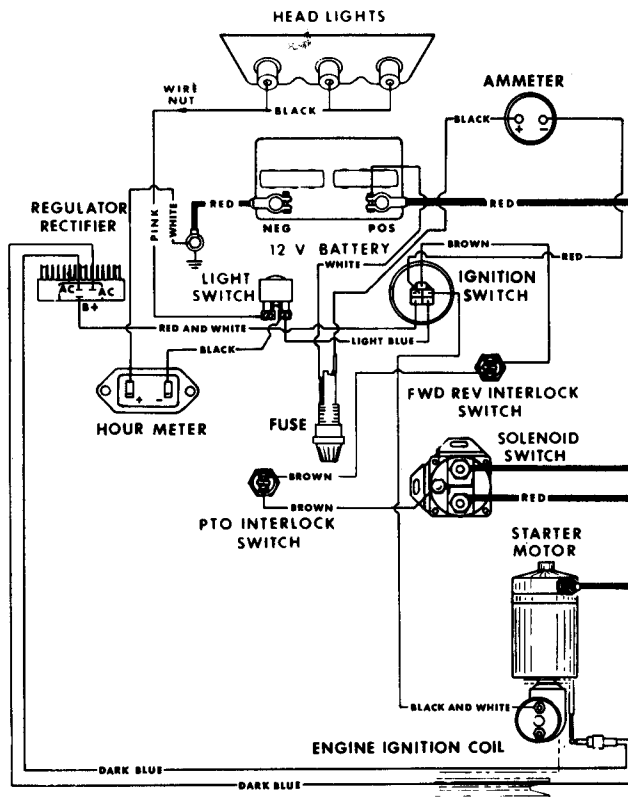

## WIRING DIAGRAM FOR 8162-T, 8163-T AND 8183-T

