

# 60" ROTARY MOWER OPERATORS MANUAL



NOTE

Read this manual carefully and learn to operate and service your 60" Rotary Mower before using it.

To keep the warranty, the 60" Rotary Mower must be maintained and operated as directed in this manual.

All references to "left-side", "right-side", "front", and "back" are given from the operator's position.



Look for this symbol to point out important safety precautions. It means -- ATTENTION! BECOME ALERT! YOUR SAFETY IS INVOLVED.

## CONTENTS

### 1. INSTRUCTIONS FOR SAFE OPERATION

### 2. OPERATING INSTRUCTIONS

### 3. SERVICE INSTRUCTIONS

### 4. STORAGE

### 5. SOLVING PROBLEMS

### 6. ILLUSTRATED PARTS AND PARTS LIST

### 7. SPECIFICATIONS

### 8. SET-UP INSTRUCTIONS

### 9. WARRANTY

## SECTION 1

### Instructions for Safe Operation

Improper use of this equipment can injure people and damage the equipment. People using or servicing this equipment must read and follow the instructions in this manual.

It is important to understand that this manual and any other Gravely instruction manuals do not cover every possible danger. It is impossible for Gravely to know all possible dangers in operating and servicing the equipment.

The purchaser must give these instructions to the people operating and maintaining this equipment. These people must use eye and foot protection.

#### 1.1 Preparation:

1. Read this manual and the tractor manual carefully.
2. Learn the location and function of all controls.
3. Learn how to use the controls to stop the wheels and mower quickly.
4. Use caution with gasoline. Gasoline is very flammable. Keep it in a clean and tight container away from flames or hot items. Never put gasoline in the fuel tank while the engine is running or hot. Clean up spilled gasoline before starting engine.
5. Be certain that all shields, guards, and interlock switches are in the correct positions.
6. Never permit children to operate the tractor and mower.
7. Inspect area to be mowed and remove all material which could be thrown by the mower.
8. Before starting the engine, put the PTO control lever in the "OFF" position and the gear shift lever in the neutral "N" position.
9. When hauling the equipment, connect the chassis to the transporting vehicle. Never connect from control levers, rods, or like items that could be damaged.
10. Replace all parts that become damaged or lost.



## 1.2 Operation:

1. Wear foot and eye protection. Do not wear loose clothing.
2. Do not use the equipment in the dark without adequate lighting.
3. Keep the equipment in good condition. Maintain it as directed in this manual.
4. USE ONLY GRAVELY ACCESSORIES AND ATTACHMENTS.
5. Do not overspeed the engine. Do not override the governor.
6. Keep away from moving parts.
7. Keep people and animals away from the operating area.
8. Do not let people other than the operator near the operating equipment.
9. Use a slow speed and engage the direction control lever slowly when operating on slopes.
10. Look for and keep away from hazards.
11. After hitting an object, stop the equipment and engine. Check for damage. Repair any damage before operating.
12. Look behind when operating in reverse. Look for people and hazards.
13. Operate only from the operator's position, just behind the handlebars or on the tractor seat.
14. Travel up and down slope.
15. If there is a sudden change in the sound or vibration of the equipment, stop the engine and check for damage. Repair any damage or failure before continuing operation.
16. Never run the engine indoors except to move it outside. Exhaust fumes are dangerous.
17. Go slowly on slick surfaces.
18. Follow traffic laws when operating on or near a road.
19. Before making adjustments or servicing, move the PTO to "OFF," turn the ignition switch to "OFF," and wait until all moving parts completely stop.
20. Before leaving the operator's position, put the PTO lever in the "OFF" position, turn the ignition key to the "OFF" position. Set the brake lock for parking.

## SECTION 2

### Operating Instructions

- 2.1 Transport the equipment to the area to be mowed.
- 2.2 Inspect the area to be mowed and remove all material which could be thrown by the mower.
- 2.3 Plan the pattern for cutting the grass. Generally an area is mowed around the periphery towards the center by discharging the grass toward the center on the first pass. The remainder of the mowing is done discharging the grass outward in the area which has been cut.
- 2.4 See Section 7 for the schedule of heights of cut. Set the mower for the height of cut desired.
- 2.5 See the tractor manual for correct operation of the PTO. Start the engine and put the PTO Control in the "ON" position. Move the throttle control to the "FAST" position.
- 2.6 Select a slow gear. Engage the forward clutch. Control the ground speed by selecting the desired gear.

## SECTION 3

### Service Instructions

#### 3.1 Lubrication:

1. See Figures 1, 2 and 3. Every eight hours of operation apply multi-purpose grease to the lube fittings on:
  - a. Each spindle (3)
  - b. Each gauge wheel (4)
  - c. Drive shaft
  - d. Each caster fork (2)
  - e. Each idler pivot weldment (2)
2. Gear Box: Once a year or every 200 hours of operation, check the lubricant by removing the cover. Clean the top of the gear box and carefully remove the cover. Replace the gasket if damaged. Keep the gear box  $\frac{3}{4}$  full of grease.

#### 3.2 Blade Service:

1. Every ten hours of operation or when the cut is poor visually, check the blades for sharpness.
2. Remove the mower from the tractor. See Sections 3.6 and 3.7.

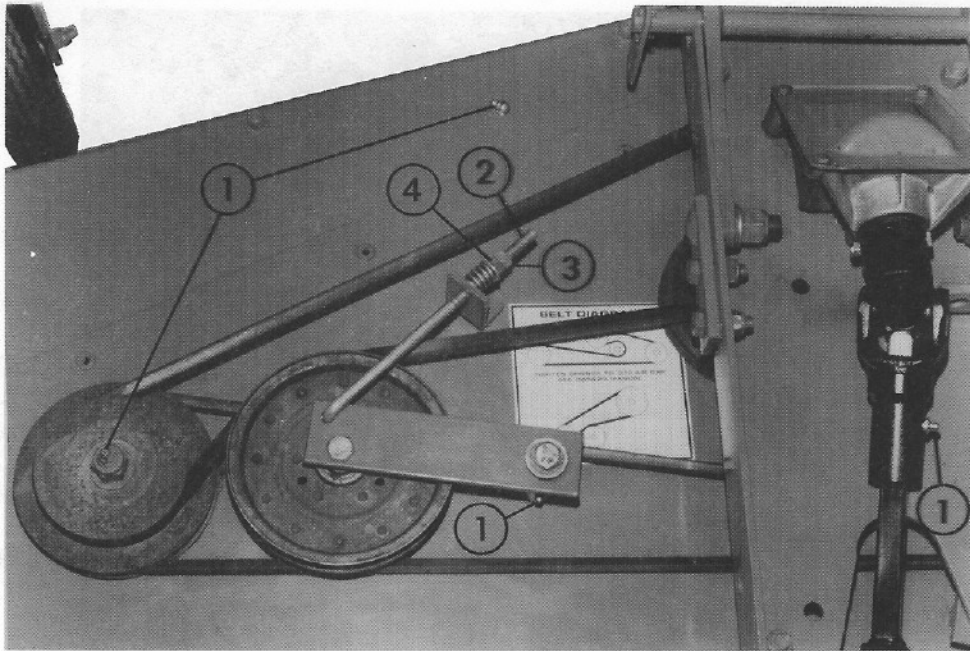

- 1 - Lube Fittings
  - 2 - Idler Rod
  - 3 - Jam Nut
  - 4 - Adjusting Nut
- FIGURE 1

84068

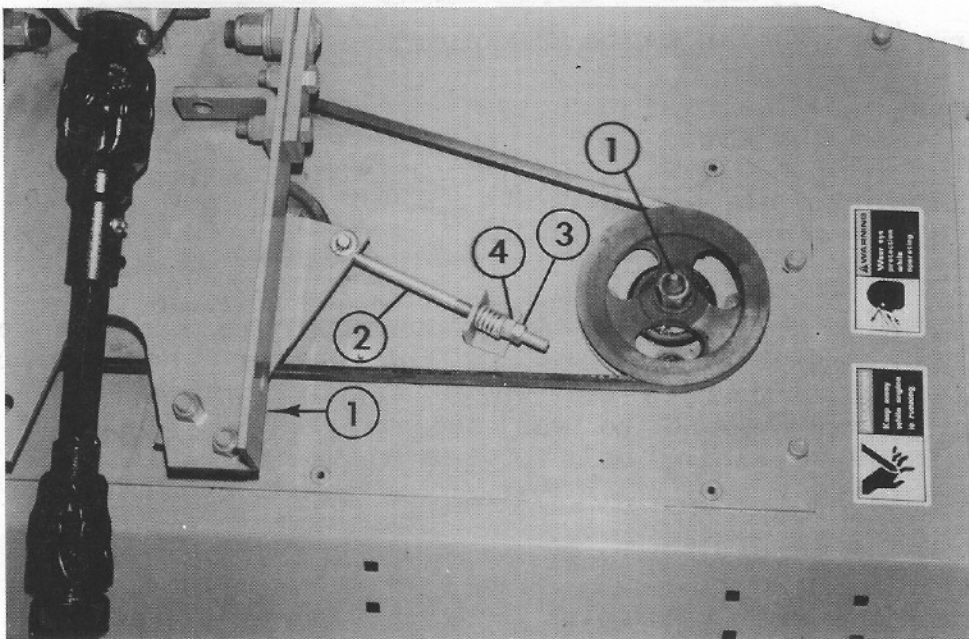

- 1 - Lube Fittings
  - 2 - Idler Rod
  - 3 - Jam Nut
  - 4 - Adjusting Nut
- FIGURE 2

84069



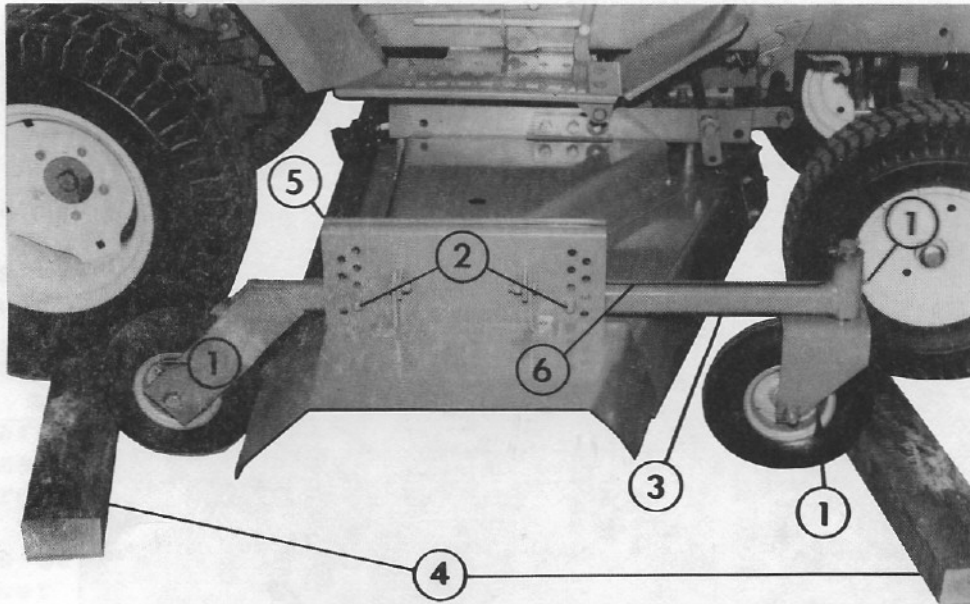

84070

- |                                    |                     |
|------------------------------------|---------------------|
| 1 - Lube Fittings                  | 4 - Blocks          |
| 2 - Height of Cut Adjustment Bolts | 5 - Hanger Assembly |
| 3 - Caster Wheel Support Weldment  | 6 - Trim Line       |

FIGURE 3

3. Turn the mower upside down.
4. Block the blades and remove the nuts and flat washers from the spindle.
5. Sharpen and balance the blade.
6. Reverse the removal process to install the blades on mower and the mower on the tractor.
7. Replace the blades when over 1/2" has been removed or the blade cannot be balanced.

3.3 Height of Cut Adjustment: Lift the mower to the transport position. Remove the bolts in the caster wheel support weldment. Move the caster wheel support weldment to the holes which correspond to the desired height position and reinstall the retaining bolts. See Figure 3.

#### 3.4 Adjustment of Belts:

1. Remove the belt covers.
2. Unlock the adjusting nuts. See Figures 1 and 2.
3. Rotate the inside nut until the air gap in the spring is .010" to .015" (.25mm to .38mm).
4. Jam the adjusting nuts.
5. Install the belt covers.



### 3.5 Belt Replacement:

1. Remove the mower from the tractor.
2. Remove the belt covers.
3. Loosen the spring tension on the belts.
4. Remove the gear housing support.
5. Remove the belts.
6. Put the new belts in position on the sheaves. See Diagram 1.
7. Mount the gear housing support.

NOTE: When installing the gear box support, make sure that the belt is around the drive pulley.

8. Adjust the tension of the belts. See Section 3.4.
9. Replace the belt covers.

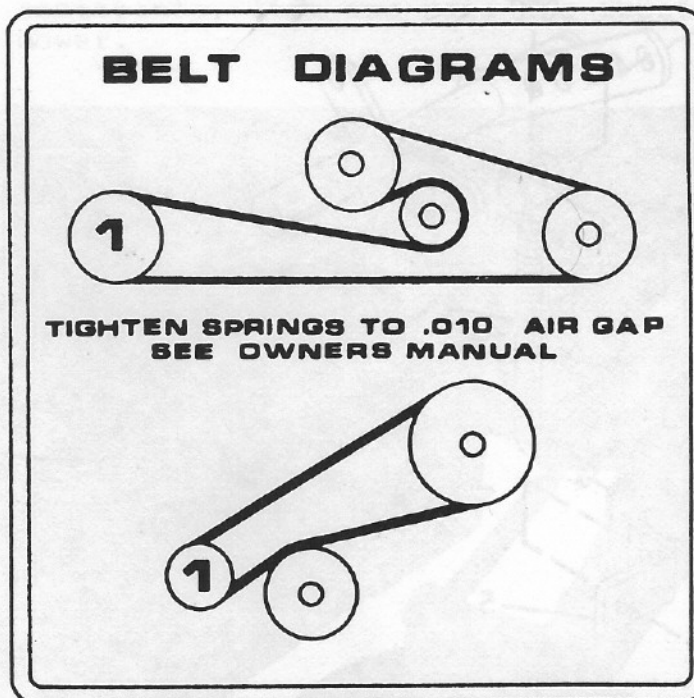

84073

DIAGRAM 1

### 3.6 Installation on the Tractor:

1. Install the lift rod on the tractor as shown in Diagram 2.
2. Put a film of grease on the shaft of the universal joint (male) assembly. Slide the shaft into the tube of the universal joint (female) assembly.
3. Put the attachment lift in the "UP" position.
4. Put a film of grease on the tractor PTO shaft.
5. Position the mower in front of the tractor. Block the mower wheels. Put the tractor direction control in the "NEUTRAL" position.
6. Get assistance and lift the front of the tractor and move it over the mower. See Figure 3.
7. Unlock the locking collar on the universal joint assembly by rotating (rotary style) or pulling (push-pull style). Slide the universal joint assembly onto the PTO shaft. Release the collar and slide back and forth on the PTO shaft to assure latching.

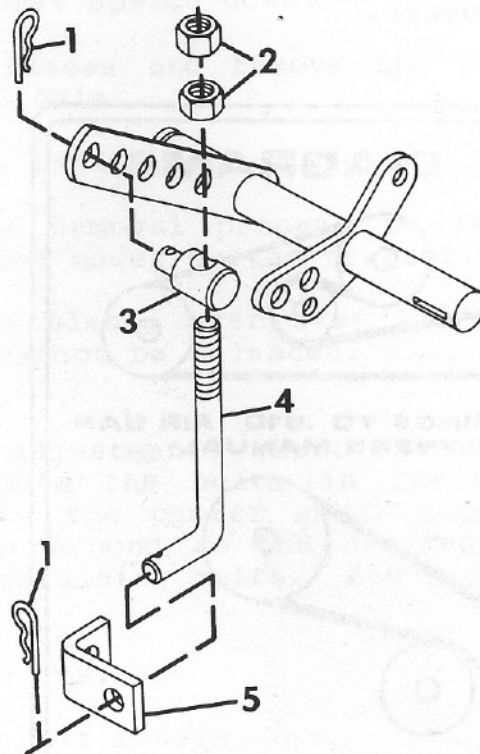

- 1 - Hair Pin Cotter
- 2 - Jam Nuts
- 3 - Mower Lift Pivot
- 4 - Lift Rod
- 5 - Lift Bracket

DIAGRAM 2

8. Lower the attachment lift. Connect the lift rod to the mower and retain with a hairpin cotter.
9. Lift the mower with the attachment lift until the pivot arm weldment will swing into the latch plates. Open the latch plates and swing the pivot arm weldment into the slot. Swing the latch plates into the lock position and retain with hairpin cotters. See Figure 4.
10. Lift the mower to the transport position with the attachment lift. Hook the springs to the spring tabs. Pull the latch over the latch pin and lock.

### 3.7 Mower Removal:

1. Lift the mower with the attachment lift to the transport position. Unlatch the lift springs.
2. Remove the hairpin cotters from the latch plates and unlatch.
3. Lower the mower and disconnect the lift link and the drive.
4. Block the mower so that it will not roll backwards.
5. Put the direction control in the "NEUTRAL" position.
6. Get assistance, lift and roll the tractor backwards over the mower.

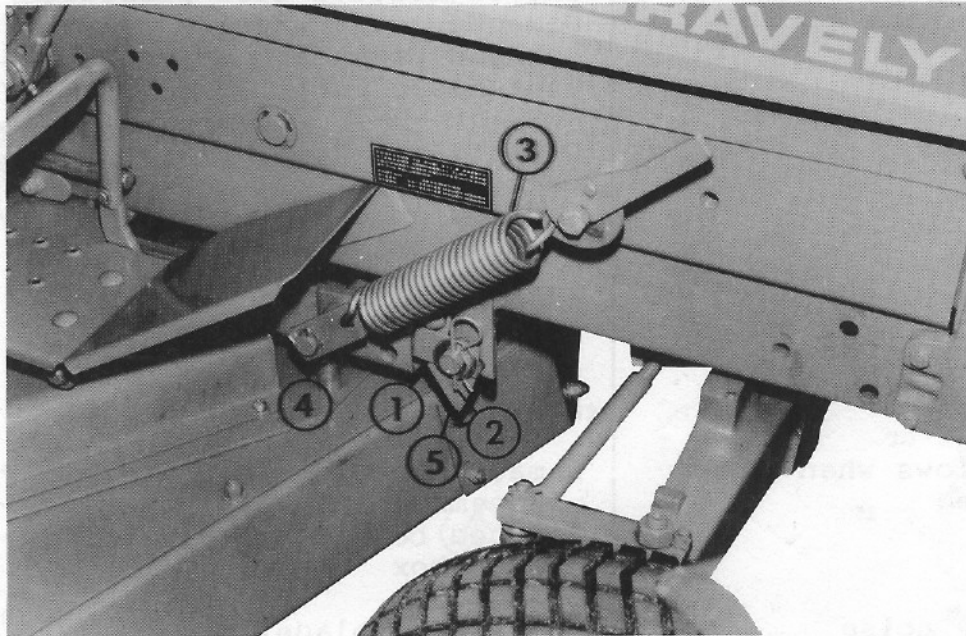

- |                        |                 |
|------------------------|-----------------|
| 1 - Mower Pivot Keeper | 4 - Strap       |
| 2 - Hair Pin Cotter    | 5 - Latch Plate |
| 3 - Extension Spring   |                 |

FIGURE 4



## SECTION 4

### Storage

- 4.1 Remove the mower from the tractor and clean.
- 4.2 Inspect for damage, wear, loose or missing hardware. Repair as needed.
- 4.3 Sharpen and balance the blades.
- 4.4 Lubricate.
- 4.5 Paint any bare areas.
- 4.6 Place in a dry area.

## SECTION 5

### Solving Problems

#### Problem Chart:

OBSERVATION	POSSIBLE CAUSE
1. Uneven cut	Deck not level Uneven tractor tire pressure Damaged gauge wheel or axle Damaged pivot arm weldment Bent blade
2. Uncut grass	Dull blade Damaged blade Too low engine speed Mowing tall grass Tractor ground speed too fast
3. Smoke from mower	Spindle/blade locked Debris wedged against belt Loose belt
4. Engine slows when mower is engaged	Damaged bearing in spindle assembly Damaged bearings/gears in the gear box
5. Excessive noise	Unbalanced blade(s) Damaged universal joint Damaged gear box bearings/gears Idler bearings Damaged bearings in spindle assembly



SECTION 6

Illustrated Parts and Parts List

**MOWER DRIVE**

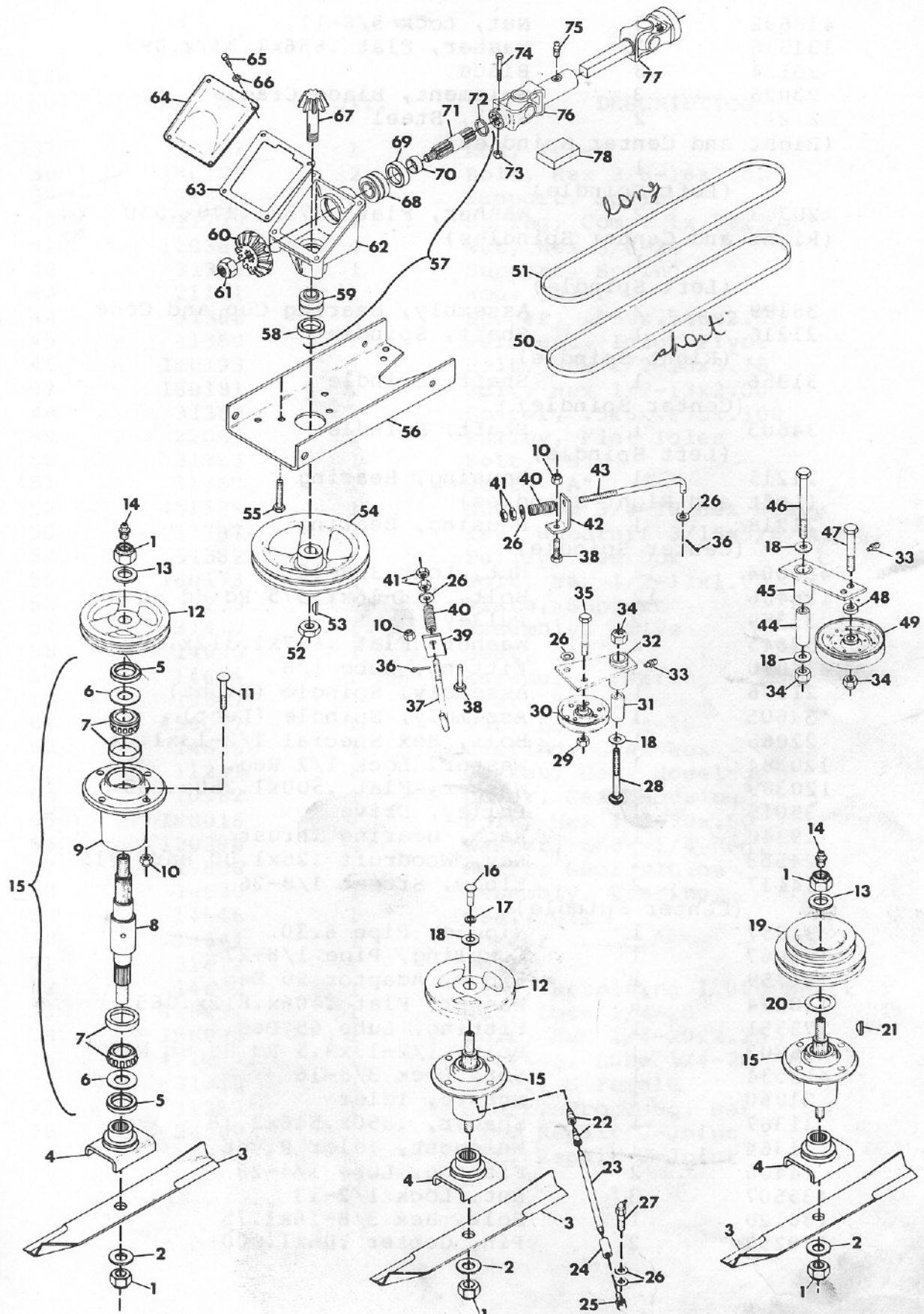

## MOWER DRIVE

ITEM NO.	PART NO.	QTY.	DESCRIPTION
1	418692	5	Nut, Lock 5/8-11
2	131016	3	Washer, Flat .656x1.312x.095
3	25124	3	Blade
4	23026	3	Weldment, Blade Cradle
5	21211	2	Seal, Steel
			(Right and Center Spindles)
		1	(Left Spindle)
6	20743	2	Washer, Flat .975x1.970x.030
			(Right and Center Spindles)
		1	(Left Spindle)
7	38199	2	Assembly, Bearing Cup and Cone
8	21216	1	Shaft, Spindle
			(Right Spindle)
	31356	1	Shaft, Spindle
			(Center Spindle)
	34603	1	Shaft, Spindle
			(Left Spindle)
9	21215	1	Housing, Bearing
			(Left and Right Spindles)
	21218	1	Housing, Bearing
			(Center Spindle)
10	456004	14	Nut, Lock 3/8-16
11	126406	12	Bolt, 3/8-16x1.375 Rd Hd Sq Nk
12	31359	2	Pulley
13	33845	2	washer, Flat .687x1.312x.122
14	411010	3	Fitting, Lube 1/8
15	21306	1	Assembly, Spindle (Right)
	34605	1	Assembly, Spindle (Left)
16	22065	1	Bolt, Hex Special 1/2-13x1.34
17	120384	1	Washer, Lock 1/2 Reg.
18	120389	4	Washer, Flat .500x1.250x.083
19	35015	1	Pulley, Drive
20	19340	1	Race, Bearing Thrust
21	124553	1	Key, Woodruff .25x1.00 Hard #15
22	144117	2	Elbow, Street 1/8-26
			(Center Spindle)
23	31357	1	Nipple, Pipe 6.30
24	144067	1	Coupling, Pipe 1/8-27
25	191759	1	Elbow, Adaptor 90 Deg.
26	120394	6	Washer, Flat .406x.812x.065
27	273351	1	Fitting, Lube 65 Deg.
28	126803	1	Bolt, 1/2-13x3.5 Rd Hd Sq Nk
29	413534	1	Nut, Lock 3/8-16
30	21060	1	Sheave, Idler
31	31367	1	Spacer, .850x.546x2.18
32	31364	1	Weldment, Idler Pivot
33	14406	2	Fitting, Lube 1/4-28
34	435507	3	Nut, Lock 1/2-13
35	180128	1	Bolt, Hex 3/8-16x1.75
36	179252	2	Pin, Cotter .06x1.000

## MOWER DRIVE

ITEM NO.	PART NO.	QTY.	DESCRIPTION
37	21112	1	Rod, Idler
38	180122	2	Bolt, Hex 3/8-16x1.00
39	31345	1	Support, Spring
40	11779	2	Spring, Comp. 1x.78x338
41	120369	4	Nut, Hex 3/8-24
42	31346	1	Support, Spring
43	21111	1	Rod, Idler
44	31363	1	Spacer, .850x.546x2.50
45	31360	1	Weldment, Idler Pivot
46	180193	1	Bolt, Hex 1/2-13x3.75
47	180181	1	Bolt, Hex 1/2-13x2.00
48	31368	1	Spacer, .516x.875x.300
49	22063	1	Pulley, Flat Idler
50	31383	1	Belt, "B"
51	31369	1	Belt, "A"
52	451539	1	Nut, Jam 3/4-10 Hex Heavy
53	431787	1	Key, Woodruff 3/16x5/8 No. 61
54	31382	1	Pulley, Gearbox
55	180173	3	Bolt, Hex 1/2-13x1.00
56	35779	1	Plate, Support
57	31410	1	Assembly, Drive
58	14645	1	Seal, Oil
59	14644	1	Assembly, Bearing
60	19607	1	Gear, Bevel
61	456007	1	Nut, Lock 3/4-10
62	14636	1	Casting, Gear Box
63	11231	1	Gasket, Gear Housing
64	10982	1	Cover, Gear Housing
65	180016	4	Bolt, Hex 1/4-20x.50
66	120380	4	Washer, Lock 1/4 Reg.
67	19608	1	Shaft, Gear Pinion
68	14640	1	Assembly, Bearing
69	14646	1	Seal, Oil
70	14641	1	Spacer
71	31412	1	Shaft
72	14642	1	Ring, Retaining 1.000 Shaft
73	419454	1	Nut, Lock 1/4-20
74	180046	1	Bolt, Hex 1/4-20x2.25
75	411027	1	Fitting, Lube 1/4-28
76	31388	1	Joint, U Female
77	31389	1	Shaft, Prop. Sq. Bar
78	24560	1	Kit, Repair U-Joint
	31828	1	Kit, Repair U-Joint



# MOWER DECK ASSEMBLY

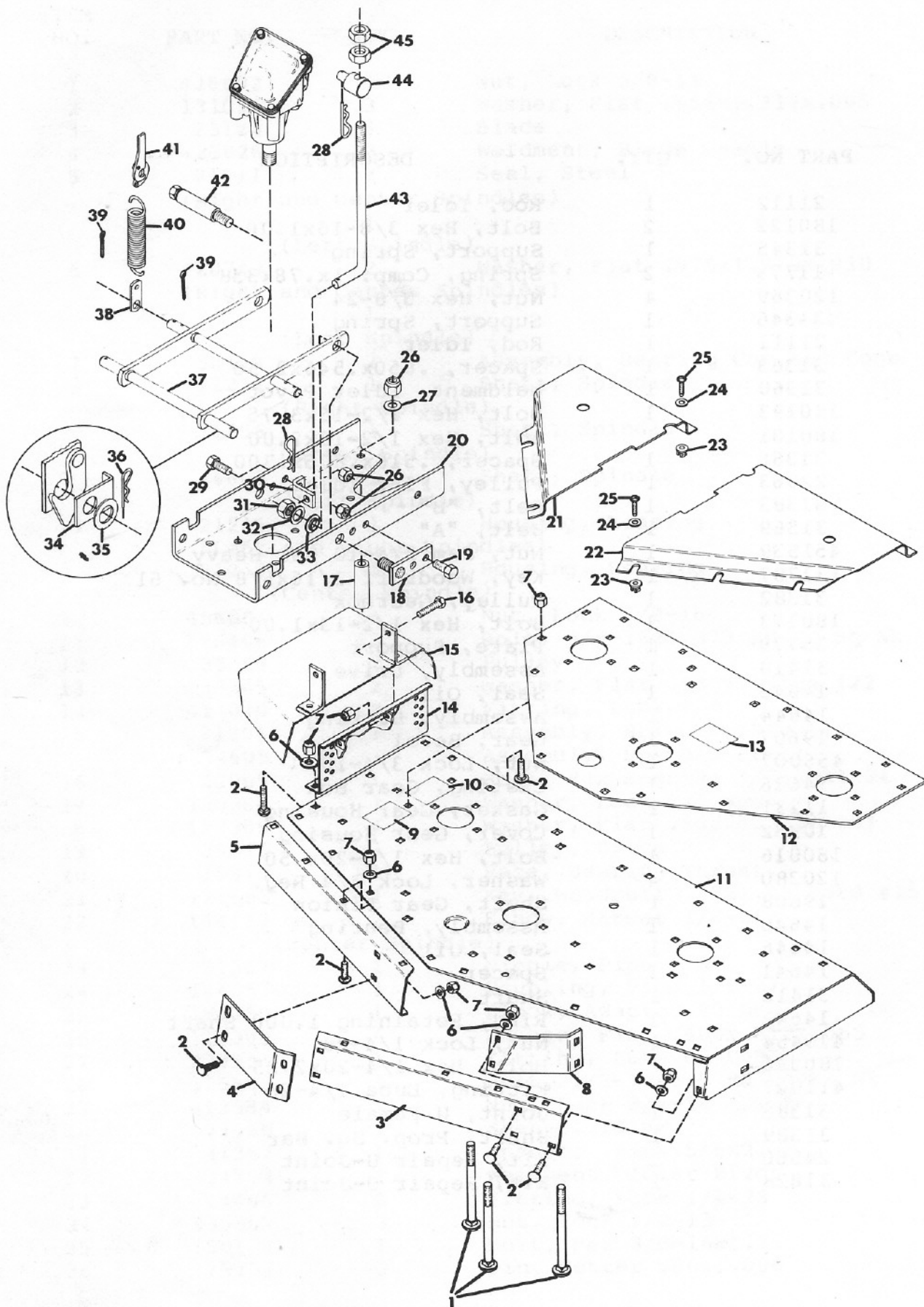



## MOWER DECK ASSEMBLY

ITEM NO.	PART NO.	QTY.	DESCRIPTION
1	126803	4	Bolt, 1/2-13x3.50 Rd Hd Sq Nk
2	120915	23	Bolt, 3/8-16x1.00 Rd Hd Sq Nk
3	31344	1	Plate, Front Cover L.H.
4	35648	1	Bracket, Front Deck
5	35666	1	Plate, Front Cover
6	120394	19	Washer, Flat .406x.812x.065
7	456004	25	Nut, Lock 3/8-16
8	31354	1	Baffle, Front
9	33928	1	Decal, Warning Eye
10	33926	1	Decal, Danger Hand
11	35551	1	Weldment, 60" OFC
12	31342	1	Plate, Deck Support
13	31834	1	Decal, Belt Diagram
14	37988	1	Weldment, 60" Hanger
15	35668	1	Weldment, Discharge Chute
16	180124	2	Bolt, Hex 3/8-16x1.25
17	31367	4	Spacer, .850x.546x2.18
18	37987	2	Weldment, Pivot Anchor
19	180177	3	Bolt, Hex 1/2-13x1.50
20	35779	1	Plate, Support
21	38000	1	Cover, Belt R.H.
22	38001	1	Cover, Belt L.H.
23	11777	10	Grommet, Plastic
24	120392	10	Washer, Flat .281x.625x.065
25	160536	10	Screw, Mach. 1/4-20x.625 Rd Hd
26	435507	8	Nut, Lock 1/2-13
27	120396	4	Washer, Flat .531x1.062x.095
28	15691	2	Pin, Cotter Hair
29	180179	1	Bolt, Hex 1/2-13x1.75
30	37984	1	Bracket, Lift
31	34112	2	Nut, Lock 3/4-10
32	11223	2	Race, Bearing Thrust
33	10174	2	Bushing, Nylon .76x1.00x.6 Flange
34	37982	2	Keeper, Mower Pivot
35	423315	AR	Washer, Flat .813x1.37x.100
36	10405	2	Pin, Hair
37	35777	1	Weldment, Pivot Arm
38	11273	2	Strap
39	120123	4	Pin, Cotter .125x.1.125
40	11272	2	Spring, Ext. 7.625x1.50x70 Rate
41	11274	1	Latch, Spring Assembly R.H.
42	31688	2	Latch, Pin
43	19201	1	Rod, Lift
44	11262	1	Pivot, Mower Lift
45	120238	2	Nut, Jam 1/2-13 Hex
NS	38769	1	Stripe
NS	11275	1	Latch, Spring Assembly L.H.

# GAUGE WHEELS AND HEIGHT ADJUSTMENT

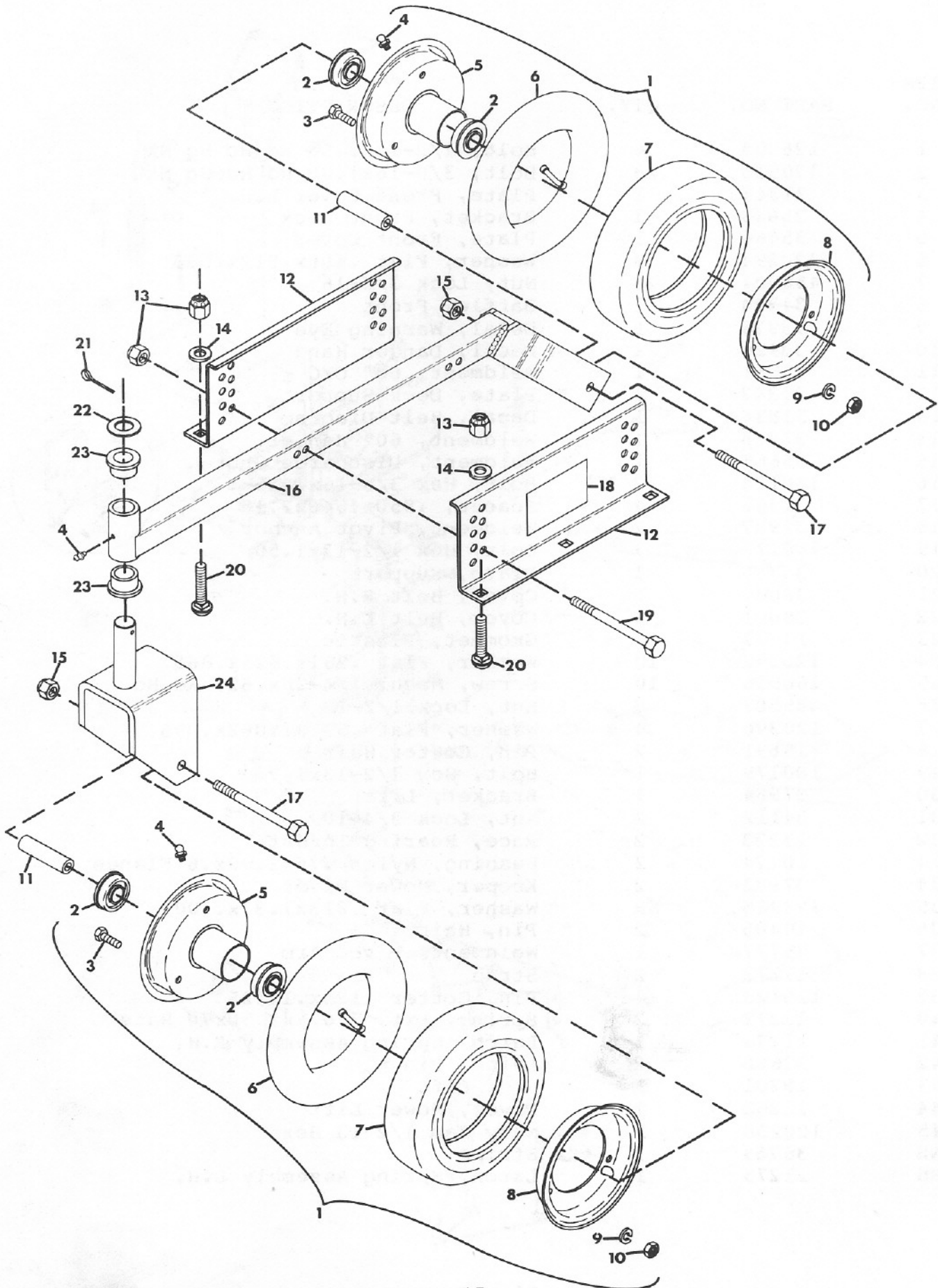

## GAUGE WHEELS AND HEIGHT ADJUSTMENT

ITEM NO.	PART NO.	QTY.	DESCRIPTION
1	37797	4	Wheel, Gauge
2	37823	2	Bearing, Gauge Wheel
3	181635	3	Bolt, Hex 3/8-24x.75
4	411027	3	Fitting, Lube 1/4-28
5	37825	1	Wheel, Half with Tube
6	37826	1	Tube, Inner
7	37827	1	Tire, Gauge Wheel
8	37824	1	wheel, Half Plain
9	131099	3	Washer, Lock 3/8 SP Heavy
10	120369	3	Nut, Hex 3/8-24
11	11950	4	Bushing, Wheel
12	38281	3	Assembly, Hanger 60" Mower
13	456004	21	Nut, Lock 3/8-16
14	120394	9	Washer, Flat .406x.812x.065
15	435507	4	Nut, Lock 1/2-13
16	35769	2	Weldment, Caster Wheel Support
17	433163	4	Bolt, Hex 1/2-13x5.00
18	33927	1	Decal, Danger Foot
19	180134	4	Bolt, Hex 3/8-16x2.50
20	120915	9	Bolt, 3/8-16x1.00 Rd Hd Sq Nk
21	137253	2	Pin, Cotter .187x1.625
22	19340	2	Race, Bearing Thrust
23	18355	4	Bushing, Pivot
24	37811	2	weldment, Caster Fork

## SECTION 7

### Specifications

Weight:	345 lb. (157kg)
Width:	71 in. (1803mm)
Height:	15 in. (381mm)
Length:	40 in. (1016mm)
Width of Cut:	60 in. (1524mm)
Tires: Size	2.80/2.50-4
Pressure	50 PSI (345 kN/m <sup>2</sup> )
Heights of Cut:	

#### Position

#### Height of Cut

1	1.0 inches (25.4mm)
2	1.5 inches (38.1mm)
3	2.0 inches (50.8mm)
4	2.5 inches (63.5mm)
5	3.0 inches (76.2mm)
6	3.5 inches (88.9mm)
7	4.0 inches (101.6mm)
8	4.5 inches (114.3mm)



## SECTION 8

### Set-Up Instructions

- 8.1 Remove mower from the shipping container. Block the mower approximately 6" off the floor.
- 8.2 Set the caster wheel support assemblies between the hangers. See Figure 3.
- 8.3 Tighten the bolts on the inside hanger.
- 8.4 Service the mower. See Section 3.
- 8.5 Lower the attachment lift. Install the lift pivot in the first hole of the lift arm. See Diagram 2.
- 8.6 Move the caster wheel supports to the lowest height of cut position. Retain with two bolts each. Put the end of the lift rod in the lift bracket and secure with a hair pin cotter.
- 8.7 Move the first jam nut to an 1/8" from the lift pivot and lock it in place by jamming with the second nut.
- 8.8 Move the caster wheel supports to the set of holes which correspond to the desired height of cut position.
- 8.9 Follow Sections 3.6 and 3.7 for installation and removal of the mower on the tractor.

## SECTION 9

### GRAVELY LIMITED WARRANTY

This Limited Warranty is issued by Gravelly International, Inc., and consists of the following terms:

1. Only the original purchaser of new Gravelly equipment is covered by this Warranty.
2. This Warranty covers repair or replacement of parts manufactured by Gravelly which are defective in material or workmanship. Gravelly will pay for parts and labor only.
3. The Warranty starts the date of purchase and lasts for TWELVE (12) MONTHS.
4. Some components of Gravelly equipment are not covered by the Gravelly Warranty. These components are covered by the original manufacturer's warranty, which is included with the product. They are:
  - a. Engines
  - b. Tires
5. To obtain warranty service on Gravelly equipment including components not manufactured by Gravelly, use this procedure:
  - a. Notify the Gravelly dealer from whom you purchased the equipment.
  - b. If you have moved and it is not convenient to notify the selling dealer, notify the nearest Gravelly dealer. You should supply this dealer with a copy of the bill of sale as proof of the date of purchase.
  - c. Make arrangements to have the equipment delivered to the dealer (refer to paragraph 6(a) below).
  - d. If you have any questions concerning the Gravelly Limited Warranty, they should be referred to:

Gravelly International, Inc.  
One Gravelly Lane  
Clemmons, NC 27012

Attn: Manager of Customer Services
  - e. Warranty service on Gravelly equipment must be performed by an authorized Gravelly dealer or Gravelly factory branch.
6. This Warranty does not cover the following:
  - a. Transportation between owner's home or place of business and the dealership. If the dealer provides the transportation of the equipment, he will charge the owner his usual rate for such service.
  - b. Normal maintenance services and normal replacement of items such as spark plugs, belts, oil, oil filters, air filters, and mower, plow or cultivator blades.
  - c. Alterations or Modifications - All obligations under this warranty shall be terminated if the equipment is altered or modified in any way.
  - d. Customer Neglect or Lack of Proper Maintenance - The purchaser is responsible for making sure that the tractor is operated and serviced as directed in the operator's manual. Incorrect use or maintenance will void the warranty.
7. GRAVELLY MAKES NO OTHER EXPRESS WARRANTIES. ANY IMPLIED WARRANTIES, INCLUDING WARRANTIES AS TO MERCHANTABILITY OR FITNESS FOR A PARTICULAR PURPOSE, ARE LIMITED IN DURATION TO THE PERIOD SET OUT IN PARAGRAPH 3 ABOVE. SOME STATES DO NOT ALLOW LIMITATIONS ON HOW LONG AN IMPLIED WARRANTY LASTS, SO THE ABOVE STATEMENT MAY NOT APPLY TO YOU.
8. GRAVELLY SHALL HAVE NO RESPONSIBILITY FOR INCIDENTAL OR CONSEQUENTIAL DAMAGES RESULTING FROM THE BREACH OF ANY WARRANTY, INCLUDING, BUT NOT LIMITED TO, INCONVENIENCE, RENTAL OR PURCHASE OF REPLACEMENT EQUIPMENT, LOSS OF PROFITS OR COMMERCIAL LOSS. SOME STATES DO NOT ALLOW THE EXCLUSION OR LIMITATION OF INCIDENTAL OR CONSEQUENTIAL DAMAGES, SO THE ABOVE LIMITATION OR EXCLUSION MAY NOT APPLY TO YOU.
9. This Warranty gives you specific legal rights, and you may have other rights which vary from state to state.
10. A Gravelly product registration card is supplied with each Gravelly product. Please complete the card and return it to Gravelly at the address listed on the card. The equipment registration card will be used by Gravelly for:
  - a. Recording date of purchase.
  - b. Notification of owners in compliance with the Consumer Product Safety Act, should any notification be necessary.The return of registration card is not required in order to take advantages of this Warranty.
11. This Warranty is not subject to change or modification by anyone, including Gravelly dealers and no Gravelly dealer is authorized to make any representations or promises on Gravelly's behalf.

 **GRAVELLY**