



NOTE

60" CENTER MOUNT MOWER OPERATOR'S MANUAL



NOTE

Read this manual carefully and learn to operate and service your 60" Rotary Mower before using it.

To keep the warranty, the 60" Rotary Mower must be maintained and operated as directed in this manual.

All references to "left-side", "right-side", "front", and "back" are given from the operator's position.

Use the serial number to ensure prompt and correct service when ordering parts, requesting service or making inquiries.

SERIAL NUMBER _____



Look for this symbol to point out important safety precautions. It means -- ATTENTION! BECOME ALERT! YOUR SAFETY IS INVOLVED.

CONTENTS

1. INSTRUCTIONS FOR SAFE OPERATION

2. OPERATING INSTRUCTIONS

3. SERVICE INSTRUCTIONS

4. STORAGE

5. SOLVING PROBLEMS

6. ILLUSTRATED PARTS AND PARTS LIST

7. SPECIFICATIONS

8. SET-UP INSTRUCTIONS

9. WARRANTY

SECTION 1

Instructions for Safe Operation

Improper use of this equipment can injure people and damage the equipment. People using or servicing this equipment must read and follow the instructions in this manual.

It is important to understand that this manual and any other Gravely instruction manuals do not cover every possible danger. It is impossible for Gravely to know all possible dangers in operating and servicing the equipment.

The purchaser must give these instructions to the people operating and maintaining this equipment. These people must use eye and foot protection.

1.1 Preparation:

1. Read this manual and the tractor manual carefully.
2. Learn the location and function of all controls.
3. Learn how to use the controls to stop the wheels and mower quickly.
4. Use caution with gasoline. Gasoline is very flammable. Keep it in a clean and tight container away from flames or hot items. Never put gasoline in the fuel tank while the engine is running or hot. Clean up spilled gasoline before starting engine.
5. Be certain that all shields, guards, and interlock switches are in the correct positions.
6. Never permit children to operate the tractor and mower.
7. Inspect area to be mowed and remove all material which could be thrown by the mower.
8. Before starting the engine, put the PTO control lever in the "OFF" position and the gear shift lever in the neutral "N" position.
9. When hauling the equipment, connect the chassis to the transporting vehicle. Never connect from control levers, rods, or like items that could be damaged.
10. Replace all parts that become damaged or lost.

1.2 Operation:

1. Wear foot and eye protection. Do not wear loose clothing.
2. Do not use the equipment in the dark without adequate lighting.
3. Keep the equipment in good condition. Maintain it as directed in this manual.
4. USE ONLY GRAVELY ACCESSORIES AND ATTACHMENTS.
5. Do not overspeed the engine. Do not override the governor.
6. Keep away from moving parts.
7. Keep people and animals away from the operating area.
8. Do not let people other than the operator near the operating equipment.
9. Use a slow speed and engage the direction control lever slowly when operating on slopes.
10. Look for and keep away from hazards.
11. After hitting an object, stop the equipment and engine. Check for damage. Repair any damage before operating.
12. Look behind when operating in reverse. Look for people and hazards.
13. Operate only from the operator's position, on the tractor seat.
14. Travel up and down slope.
15. If there is a sudden change in the sound or vibration of the equipment, stop the engine and check for damage. Repair any damage or failure before continuing operation.
16. Never run the engine indoors except to move it outside. Exhaust fumes are dangerous.
17. Go slowly on slick surfaces.
18. Follow traffic laws when operating on or near a road.
19. Before making adjustments or servicing, move the PTO to "OFF," turn the ignition switch to "OFF," and wait until all moving parts completely stop.
20. Before leaving the operator's position, put the PTO lever in the "OFF" position, turn the ignition key to the "OFF" position. Set the brake lock for parking.

SECTION 2

Operating Instructions

⚠ CAUTION: The 60" mower is recommended for use on a Model 8179-G or Model 8199-G tractor. Mow only with the hydraulic control in the float position.

- 2.1 Transport the equipment to the area to be mowed.
- 2.2 Inspect the area to be mowed and remove all material which could be thrown by the mower.
- 2.3 Plan the pattern for cutting the grass. Generally an area is mowed around the periphery towards the center by discharging the grass toward the center on the first pass. The remainder of the mowing is done discharging the grass outward in the area which has been cut.
- 2.4 See Section 7 for the schedule of heights of cut. Set the mower for the height of cut desired.
- 2.5 See the tractor manual for correct operation of the PTO. Start the engine and put the PTO control in the "ON" position. Move the throttle control to the "FAST" position.
- 2.6 Select a slow gear. Engage the forward clutch. Control the ground speed by selecting the desired gear.

⚠ CAUTION: Do not shift the transmission gears while the tractor is moving.

SECTION 3

Service Instructions

3.1 Lubrication:

1. See Figures 1, 2 and 3. Every eight hours of operation apply multi-purpose grease to the lube fittings on:
 - a. Each spindle (3)
 - b. Each gauge wheel (4)
 - c. Drive shaft (2)
 - d. Each caster fork (2)
 - e. Each idler pivot weldment (2)
2. Gear Box: Once a year or every 200 hours of operation, check the lubricant by removing the cover. Clean the top of the gear box and carefully remove the cover. Replace the gasket if damaged. Keep the gear box 3/4 full of grease.

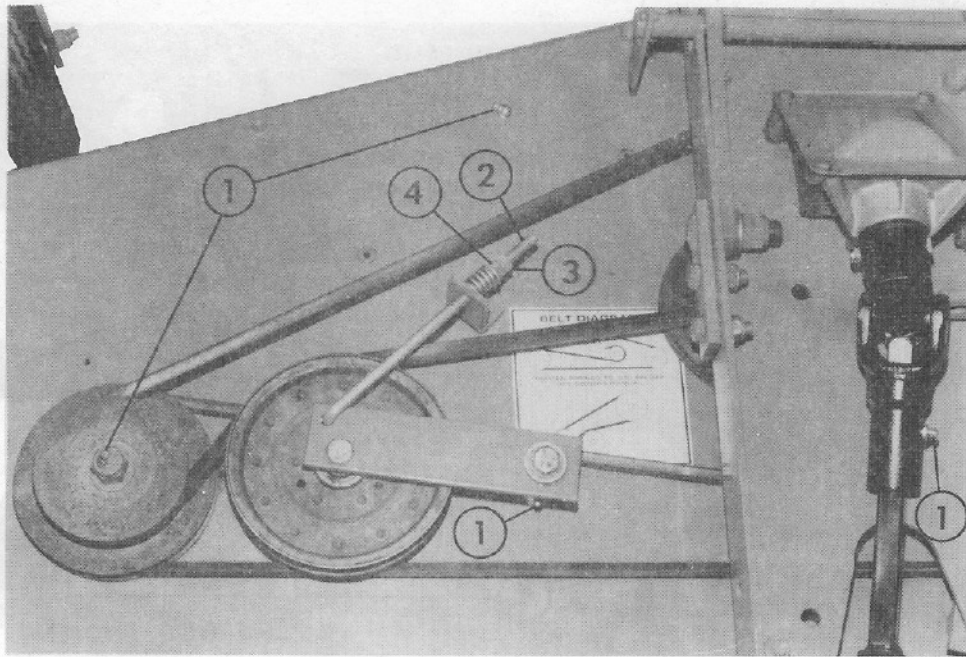

- 1 - Lube Fittings
 - 2 - Idler Rod
 - 3 - Jam Nut
 - 4 - Adjusting Nut
- FIGURE 1

84068

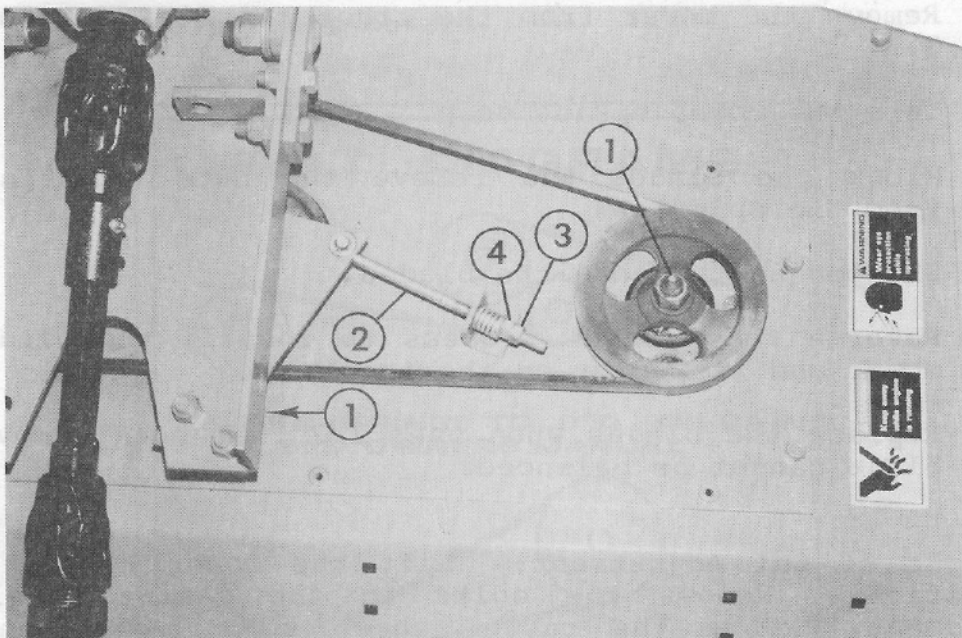

- 1 - Lube Fittings
 - 2 - Idler Rod
 - 3 - Jam Nut
 - 4 - Adjusting Nut
- FIGURE 2

84069

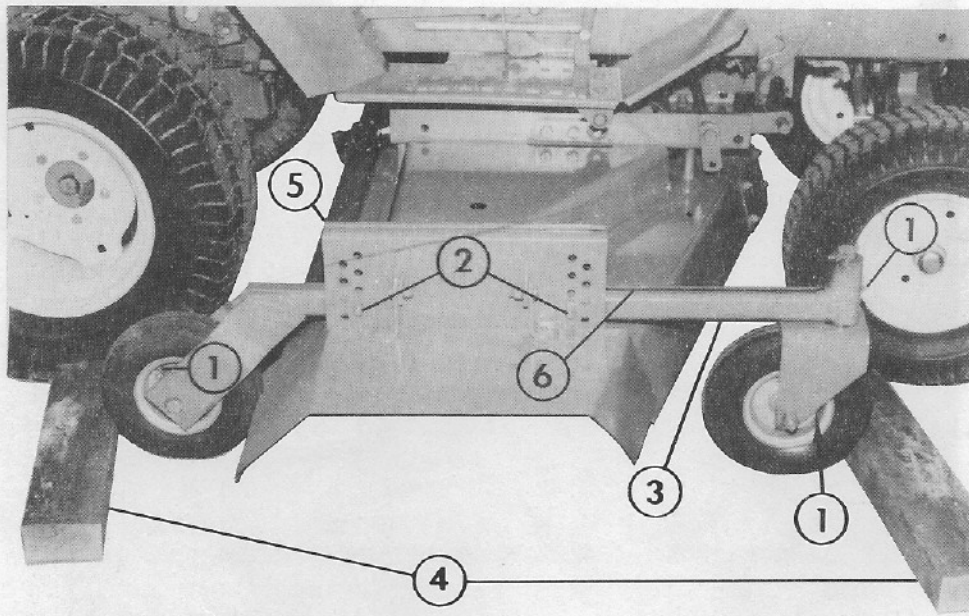

84070

- | | |
|------------------------------------|---------------------|
| 1 - Lube Fittings | 4 - Blocks |
| 2 - Height of Cut Adjustment Bolts | 5 - Hanger Assembly |
| 3 - Caster Wheel Support Weldment | 6 - Trim Line |

FIGURE 3

3.2 Blade Service:

1. Every ten hours of operation or when the cut is poor visually, check the blades for sharpness.
2. Remove the mower from the tractor. See Sections 3.6 and 3.7.
3. Turn the mower upside down.
4. Block the blades and remove the nuts and flat washers from the spindle.
5. Sharpen and balance the blades.
6. Reverse the removal process to install the blades on the mower and the mower on the tractor.
7. Replace the blades when over 1/2" has been removed or the blade cannot be balanced.

3.3 Height of Cut Adjustment: Lift the mower to the transport position. Remove the bolts in the caster wheel support weldment. Move the caster wheel support weldment to the holes which correspond to the desired height position and reinstall the retaining bolts. See Figure 3.

3.4 Adjustment of Belts:

1. Remove the belt covers.
2. Unlock the adjusting nuts. See Figures 1 and 2.

3. Rotate the inside nut until the air gap in the spring is .010" to .015" (.25mm to .38mm).
4. Jam the adjusting nuts.
5. Install the belt covers.

3.5 Belt Replacement:

1. Remove the mower from the tractor.
2. Remove the belt covers.
3. Loosen the spring tension on the belts.
4. Remove the gear housing support.
5. Remove the belts.
6. Put the new belts in position on the sheaves. See Diagram 1.
7. Mount the gear housing support.

NOTE: When installing the gearbox support, make sure that the belt is around the drive pulley.

8. Adjust the tension of the belts. See Section 3.4.
9. Replace the belt covers.

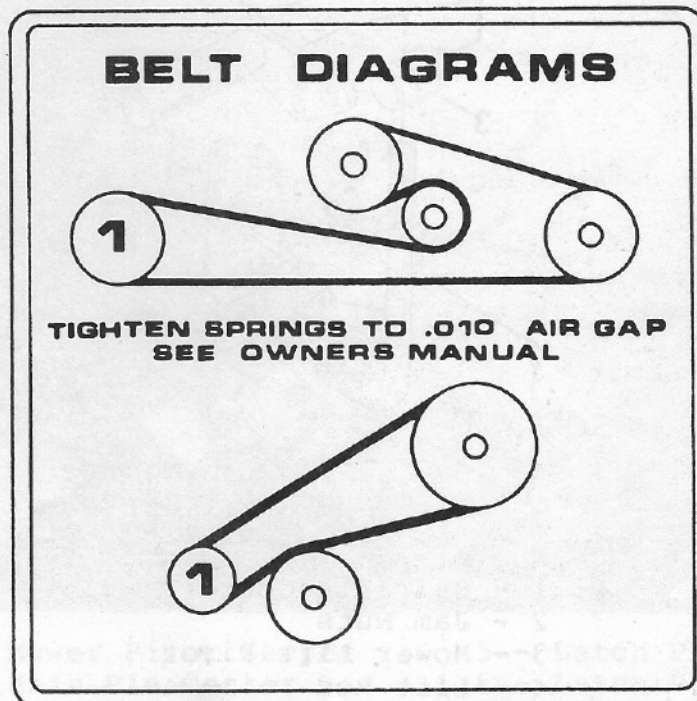

84073

DIAGRAM 1

3.6 Mower Installation:

1. Position the mower in front of the tractor and block to keep it from rolling.
2. Get assistance, lift and roll the front of the tractor over the mower. See Figure 3.
3. Align the mower pivot arm weldment with the tractor latch plates. Guide the pivot arm weldment into the latch plates and latch.
4. Put the mower pivot keepers, followed by a flat washer and hairpin cotter on the shaft on each side of the mower pivot arm weldment.
5. Put the mower lift pivot on the lift rod followed by two jam nuts. Leave the jam nuts loose at the top of the lift rod. See Diagram 2. NOTE: Adjustment of the lift rod jam nuts is required only on the first installation.
6. Put a film of grease on the prop shaft and slide it into the U-joint assembly.

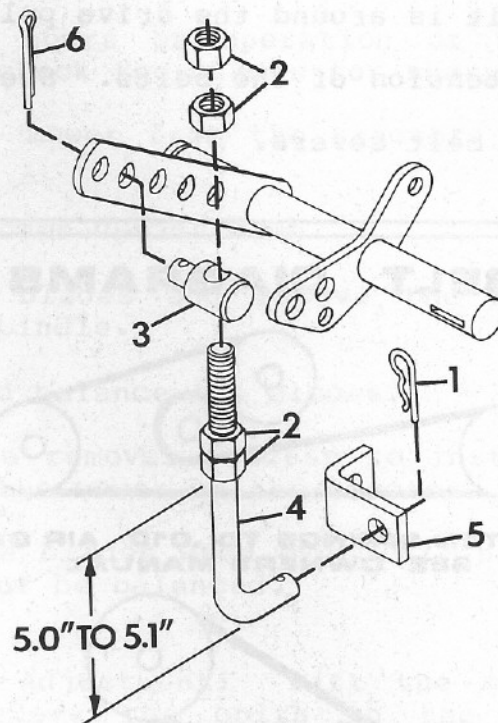

85052

- 1 - Hair Pin Cotter
- 2 - Jam Nuts
- 3 - Mower Lift Pivot
- 4 - Lift Rod
- 5 - Lift Bracket
- 6 - Cotter Pin

DIAGRAM 2

7. Put a film of grease on the PTO shaft.
8. Unlock the locking collar on the prop shaft assembly by pulling back. Slide the prop shaft assembly onto the PTO shaft. Release the locking collar and slide the prop shaft assembly back and forth on the PTO shaft to assure latching.
9. Lower the attachment lift. Connect the lift rod to the mower and the tractor lift. See Diagram 2.
10. Move the top pair of jam nuts down the lift rod until there is approximately 1/8" clearance. Jam the top pair of jam nuts. NOTE: Adjustment of the lift rod jam nuts is required only on the first installation.
11. Lift the mower to the transport position with the attachment lift. Hook the springs to the spring tabs. Pull the latch over the latch pin and lock. See Figure 4.
12. Move the caster wheel support to match the desired height of cut.

3.7 Reverse the installation procedure to remove the mower.

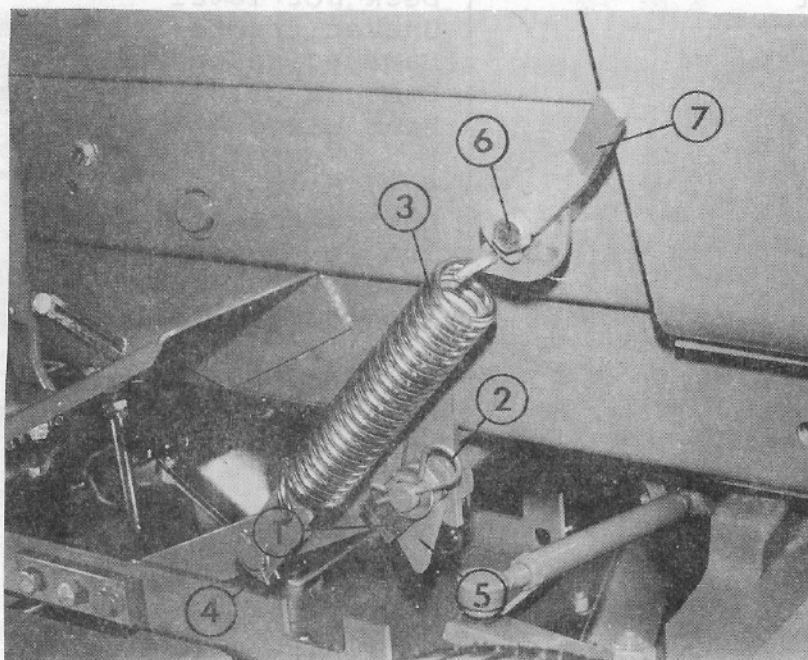

85053

- | | |
|------------------------|-----------------|
| 1 - Mower Pivot Keeper | 5 - Latch Plate |
| 2 - Hair Pin Cotter | 6 - Latch Pin |
| 3 - Extension Spring | 7 - Latch |
| 4 - Strap | |

FIGURE 4

SECTION 4

Storage

- 4.1 Remove the mower from the tractor and clean.
- 4.2 Inspect for damage, wear, loose or missing hardware. Repair as needed.
- 4.3 Sharpen and balance the blades.
- 4.4 Lubricate.
- 4.5 Paint any bare areas.
- 4.6 Place in a dry area.

SECTION 5

Solving Problems

Problem Chart:

OBSERVATION	POSSIBLE CAUSE
1. Uneven cut	Deck not level Uneven tractor tire pressure Damaged gauge wheel or axle Damaged pivot arm weldment Bent blade
2. Uncut grass	Dull blade Damaged blade Too low engine speed Mowing tall grass Tractor ground speed too fast
3. Smoke from mower	Spindle/blade locked Debris wedged against belt Loose belt
4. Engine slows when mower is engaged	Damaged bearing in spindle assembly Damaged bearings/gears in the gear box
5. Excessive noise	Unbalanced blade(s) Damaged universal joint Damaged gear box bearings/gears Idler bearings Damaged bearings in spindle assembly

SECTION 6

Illustrated Parts and Parts List

MOWER DRIVE

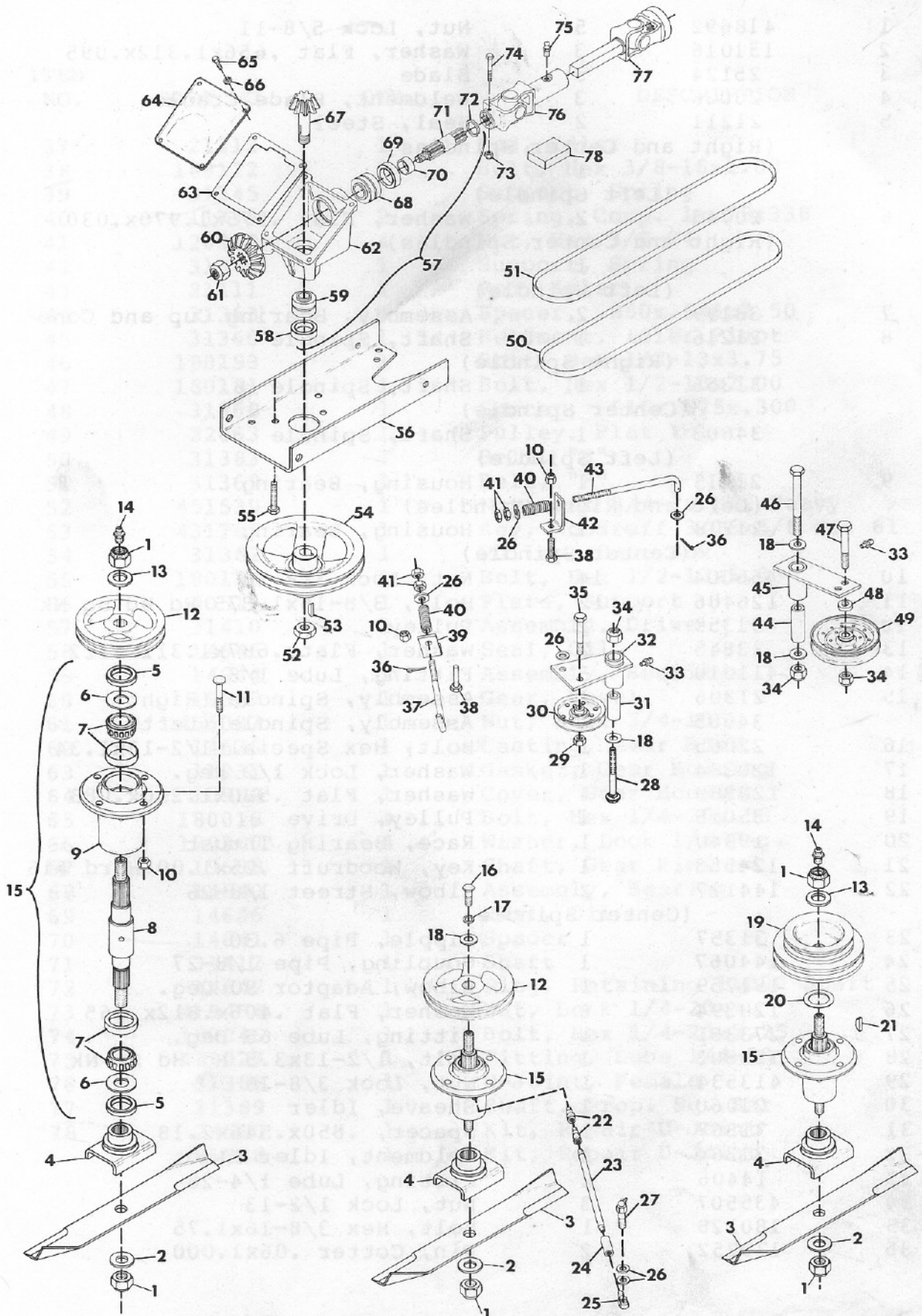

MOWER DRIVE

ITEM NO.	PART NO.	QTY.	DESCRIPTION
1	418692	5	Nut, Lock 5/8-11
2	131016	3	Washer, Flat .656x1.312x.095
3	25124	3	Blade
4	23026	3	Weldment, Blade Cradle
5	21211	2	Seal, Steel
	(Right and Center Spindles)		
		1	(Left Spindle)
6	20743	2	Washer, Flat .975x1.970x.030
	(Right and Center Spindles)		
		1	(Left Spindle)
7	38199	2	Assembly, Bearing Cup and Cone
8	21216	1	Shaft, Spindle
	(Right Spindle)		
	31356	1	Shaft, Spindle
	(Center Spindle)		
	34603	1	Shaft, Spindle
	(Left Spindle)		
9	21215	1	Housing, Bearing
	(Left and Right Spindles)		
	21218	1	Housing, Bearing
	(Center Spindle)		
10	456004	14	Nut, Lock 3/8-16
11	126406	12	Bolt, 3/8-16x1.375 Rd Hd Sq Nk
12	31359	2	Pulley
13	33845	2	Washer, Flat .687x1.312x.122
14	411010	3	Fitting, Lube 1/8
15	21306	1	Assembly, Spindle (Right)
	34605	1	Assembly, Spindle (Left)
16	22065	1	Bolt, Hex Special 1/2-13x1.34
17	120384	1	Washer, Lock 1/2 Reg.
18	120389	4	Washer, Flat .500x1.250x.083
19	35015	1	Pulley, Drive
20	19340	1	Race, Bearing Thrust
21	124553	1	Key, Woodruff .25x1.00 Hard #15
22	144117	2	Elbow, Street 1/8-26
	(Center Spindle)		
23	31357	1	Nipple, Pipe 6.30
24	144067	1	Coupling, Pipe 1/8-27
25	191759	1	Elbow, Adaptor 90 Deg.
26	120394	6	Washer, Flat .406x.812x.065
27	273351	1	Fitting, Lube 65 Deg.
28	126803	1	Bolt, 1/2-13x3.5 Rd Hd Sq Nk
29	413534	1	Nut, Lock 3/8-16
30	21060	1	Sheave, Idler
31	31367	1	Spacer, .850x.546x2.18
32	31364	1	Weldment, Idler Pivot
33	14406	2	Fitting, Lube 1/4-28
34	435507	3	Nut, Lock 1/2-13
35	180128	1	Bolt, Hex 3/8-16x1.75
36	179252	2	Pin, Cotter .06x1.000

MOWER DRIVE

ITEM NO.	PART NO.	QTY.	DESCRIPTION
37	21112	1	Rod, Idler
38	180122	2	Bolt, Hex 3/8-16x1.00
39	31345	1	Support, Spring
40	11779	2	Spring, Comp. 1x.78x338
41	120369	4	Nut, Hex 3/8-24
42	31346	1	Support, Spring
43	21111	1	Rod, Idler
44	31363	1	Spacer, .850x.546x2.50
45	31360	1	Weldment, Idler Pivot
46	180193	1	Bolt, Hex 1/2-13x3.75
47	180181	1	Bolt, Hex 1/2-13x2.00
48	31368	1	Spacer, .516x.875x.300
49	22063	1	Pulley, Flat Idler
50	31383	1	Belt, "B"
51	31369	1	Belt, "A"
52	451539	1	Nut, Jam 3/4-10 Hex Heavy
53	431787	1	Key, Woodruff 3/16x5/8 No. 61
54	31382	1	Pulley, Gear Box
55	180173	3	Bolt, Hex 1/2-13x1.00
56	40511	1	Plate, Support
57	31410	1	Assembly, Drive
58	14645	1	Seal, Oil
59	14644	1	Assembly, Bearing
60	19607	1	Gear, Bevel
61	456007	1	Nut, Lock 3/4-10
62	14636	1	Casting, Gear Box
63	11231	1	Gasket, Gear Housing
64	10982	1	Cover, Gear Housing
65	180016	4	Bolt, Hex 1/4-20x.50
66	120380	4	Washer, Lock 1/4 Reg.
67	19608	1	Shaft, Gear Pinion
68	14640	1	Assembly, Bearing
69	14646	1	Seal, Oil
70	14641	1	Spacer
71	31412	1	Shaft
72	14642	1	Ring, Retaining 1.000 Shaft
73	419454	1	Nut, Lock 1/4-20
74	180046	1	Bolt, Hex 1/4-20x2.25
75	411027	1	Fitting, Lube 1/4-28
76	31388	1	U-Joint, Female
77	31389	1	Shaft, Prop. Sq. Bar
78	24560	1	Kit, Repair U-Joint
	31828	1	Kit, Repair U-Joint

MOWER DECK ASSEMBLY

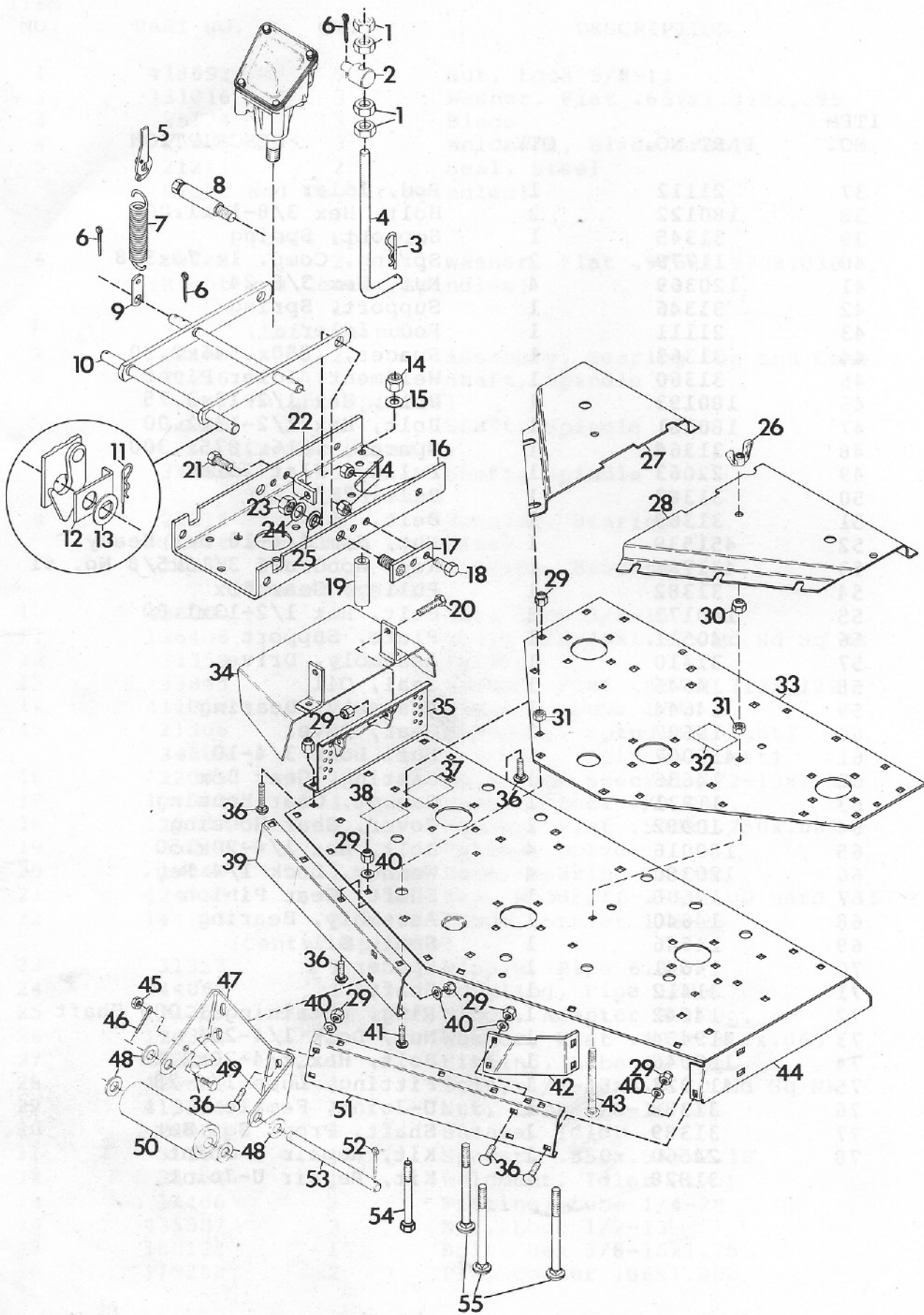

MOWER DECK ASSEMBLY

ITEM NO.	PART NO.	QTY.	DESCRIPTION
1	120238	4	Nut, Jam 1/2-13 Hex
2	11262	1	Pivot, Mower Lift
3	15691	1	Pin, Cotter Hair
4	40815	1	Rod, Lift
5	40309	1	Latch, Spring Assembly R.H.
	40311	1	Latch, Spring Assembly L.H.
6	120123	5	Pin, Cotter .125x1.125
7	11272	2	Spring, Ext. 7.625x1.50x.70 Rate
8	31688	2	Latch, Pin
9	11273	2	Strap
10	40512	1	Weldment, Pivot Arm
11	10405	2	Pin, Hair
12	37982	2	Keeper, Mower Pivot
13	423315	AR	Washer, Flat .813x1.37x.100
14	435507	8	Nut, Lock 1/2-13
15	120396	4	Washer, Flat .531x1.062x.095
16	40511	1	Plate, Support
17	37987	2	Weldment, Pivot Anchor
18	180177	3	Bolt, Hex 1/2-13x1.50
19	31367	4	Spacer, .850x.546x2.18
20	180124	2	Bolt, Hex 3/8-16x1.25
21	180179	1	Bolt, Hex 1/2-13x1.75
22	40816	1	Bracket, Lift
23	34112	2	Nut, Lock 3/4-10
24	11223	2	Race, Bearing Thrust
25	10174	2	Bushing, Nylon .76x1.00x.6 Flange
26	40194	3	Nut, Wing 5/16-18
27	40534	1	Cover, Belt R.H.
28	40535	1	Cover, Belt L.H.
29	456004	25	Nut, Lock 3/8-16
30	419455	3	Nut, Lock 5/16-18
31	124824	13	Nut, Jam 5/16-18 Hex
32	31834	1	Decal, Belt Diagram
33	40536	1	Plate, Deck Support
34	35668	1	Weldment, Discharge Chute
35	37988	1	Weldment, 60" Hanger
36	120915	23	Bolt, 3/8-16x1.00 Rd Hd Sq Nk
37	33926	1	Decal, Danger Hand
38	33928	1	Decal, Warning Eye
39	35666	1	Plate, Front Cover
40	120394	19	Washer, Flat .406x.812x.065
41	126358	10	Bolt, Carriage 5/16-18x1.00
42	31354	1	Baffle, Front
43	40546	2	Bolt, 5/16-16x4.0 Rd Hd Sq Nk
44	40538	1	Weldment, 60" Deck
45	120375	2	Nut, Hex 1/4-20
46	103422	2	Pin, Cotter .250x2.00
47	31353	1	Bracket, Front Roller
48	131016	8	Washer, Flat .656x1.312x.095
49	180020	2	Bolt, Hex 1/4-20x.75
50	31390	2	Roller, Gauge
51	31344	1	Plate, Front Cover L.H.
52	179128	2	Pin, Cotter .25x1.00
53	24795	2	Shaft, Center Roller
54	40193	1	Bolt, Hex 5/16-18x3.50
55	126803	4	Bolt, 1/2-13x3.50 Rd Hd Sq Nk
NS	38769	1	Stripe

GAUGE WHEELS AND HEIGHT ADJUSTMENT

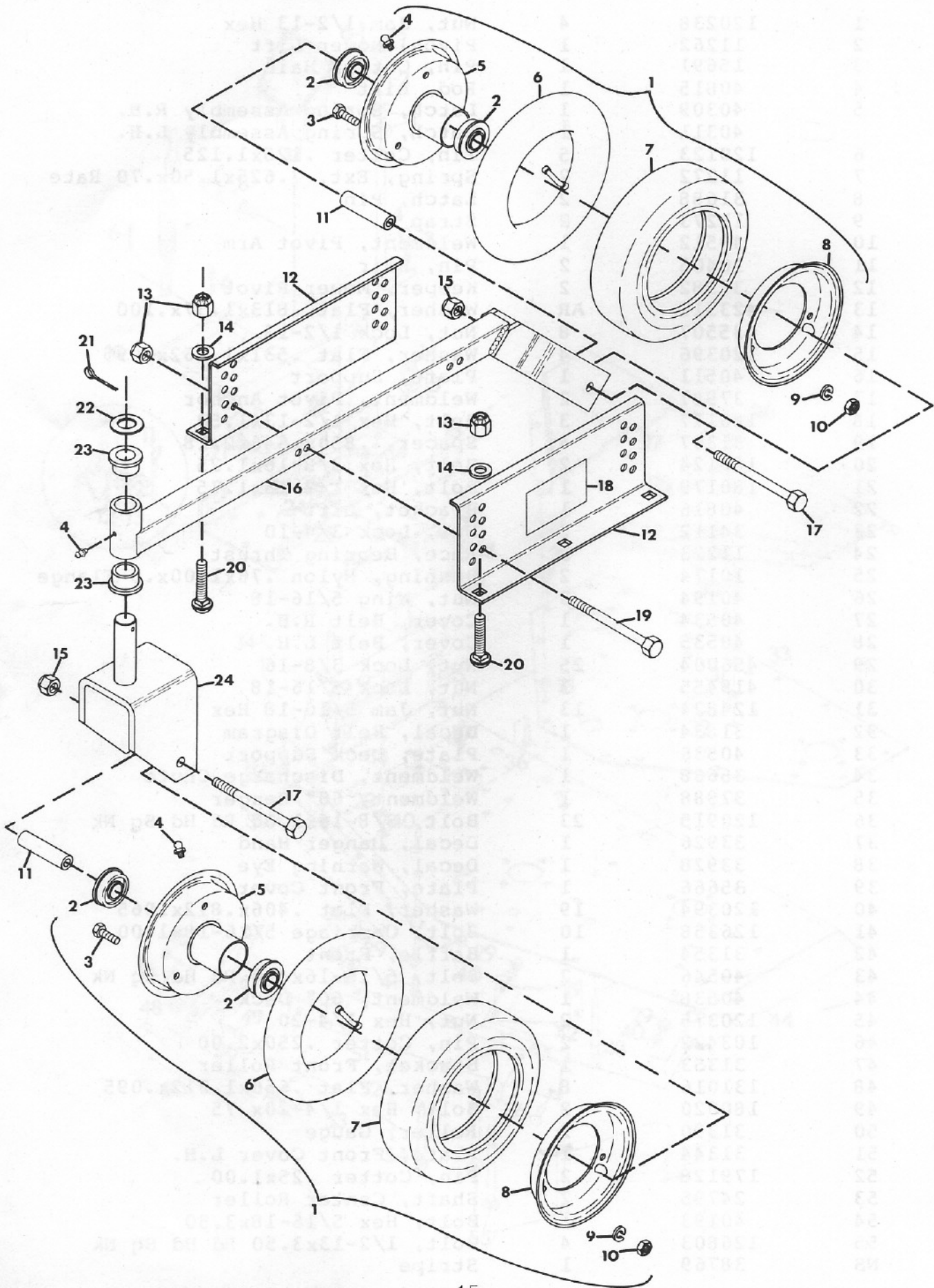

GAUGE WHEELS AND HEIGHT ADJUSTMENT

ITEM NO.	PART NO.	QTY.	DESCRIPTION
1	37997	4	Wheel, Gauge
2	37823	2	Bearing, Gauge Wheel
3	181635	3	Bolt, Hex 3/8-24x.75
4	411027	3	Fitting, Lube 1/4-28
5	37825	1	Wheel, Half with Hub
6	37826	1	Tube, Inner
7	37827	1	Tire, Gauge Wheel
8	37824	1	Wheel, Half Plain
9	131099	3	Washer, Lock 3/8 SP Heavy
10	120369	3	Nut, Hex 3/8-24
11	11950	4	Bushing, Wheel
12	38281	3	Assembly, Hanger 60" Mower
13	456004	21	Nut, Lock 3/8-16
14	120394	9	Washer, Flat .406x.812x.065
15	435507	4	Nut, Lock 1/2-13
16	35769	2	Weldment, Caster Wheel Support
17	433163	4	Bolt, Hex 1/2-13x5.00
18	33927	1	Decal, Danger Foot
19	180134	4	Bolt, Hex 3/8-16x2.50
20	120915	9	Bolt, 3/8-16x1.00 Rd Hd Sq Nk
21	137253	2	Pin, Cotter .187x1.625
22	19340	2	Race, Bearing Thrust
23	18355	4	Bushing, Pivot
24	37811	2	Weldment, Caster Fork

SECTION 7

Specifications

Weight:	362 lbs. (165kg)
Width:	71 in. (1803mm)
Height:	15 in. (381mm)
Length:	40 in. (1016mm)
Width of Cut:	60 in. (1524mm)
Tires: Size	2.80/2.50-4
Pressure	40 psi (276 kN/m ²)

Heights of Cut:	Position	Height of Cut
	1	1.0 inches (25.4mm)
	2	1.5 inches (38.1mm)
	3	2.0 inches (50.8mm)
	4	2.5 inches (63.5mm)
	5	3.0 inches (76.2mm)
	6	3.5 inches (88.9mm)
	7	4.0 inches (101.6mm)
	8	4.5 inches (114.3mm)

SECTION 8

Set-Up Instructions

- 8.1 Remove the mower from the shipping container. Block the mower approximately six inches above the floor.
- 8.2 If needed, loosen the bolts which retain the mower hangers enough to set the caster wheel support assemblies between the hangers. See Figure 3.
- 8.3 Set the right caster wheel support (the one with the stripe) in the right side and the remaining assembly on the left.
- 8.4 Tighten the bolts which retain the mower hangers.
- 8.5 Move the caster wheel support assemblies to the lowest height of cut position. Retain with two bolts each.
- 8.6 Service the mower as described in Section 3.
- 8.7 Put a jam nut on the lift rod until it is 5" to 5.1" from the bottom of the lift rod. Jam a second jam nut against the first nut. See Diagram 2.
- 8.8 Cut off the prop shaft as shown in Diagram 3.
- 8.9 Adjust the tire pressure in the gauge wheels to 35 to 40 psi (240 to 276 kN/m²).
- 8.10 See Section 3.6 for mower installation.

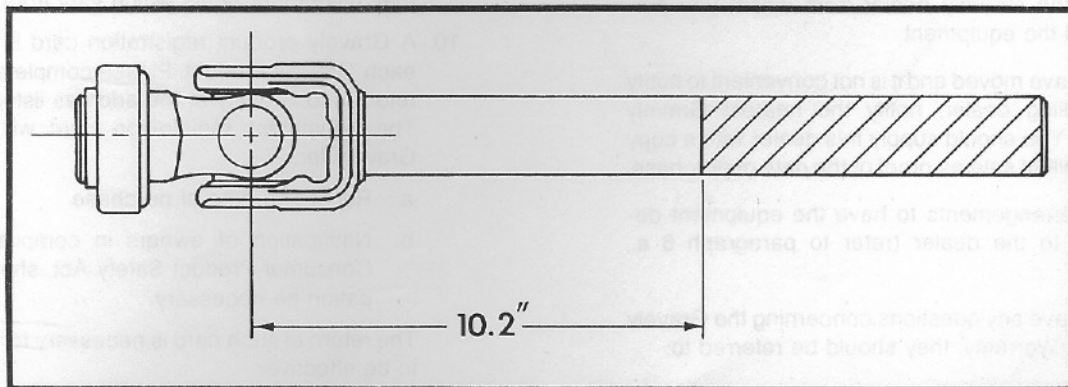

DIAGRAM 3

LIMITED FIVE-YEAR WARRANTY

1. This Limited Five-Year Warranty is issued by Gravely International, Inc., only to the original purchaser. If Gravely equipment is leased by Gravely, this Warranty shall extend also to the original lessee as if such lessee were the original purchaser.
2. Gravely warrants that all new equipment manufactured by Gravely ("Gravely Products") shall be free of defects in material and workmanship for the term described in paragraph 4, below. Except as hereinafter provided, this Warranty does not cover any engine, tires or battery forming a part of the Gravely Product. Engine and tires are covered by and subject to separate warranties of the manufacturers thereof.
3. In the event that any Gravely Product warranted hereunder shall be defective or fail to conform with this Warranty, Gravely shall, subject to the provisions hereof, pay for, or provide labor and materials for, the repair or replacement of such defective Gravely Product.
4. This Warranty is for five years (60 months) from purchase date for Gravely Products used exclusively for personal, family or household purposes, and two years (24 months) for products used for other purposes (commercial use), excluding rental firms. Gravely products used for rental purposes will be warranted for 90 days. Repair of Gravely Products after the second year (24 months from date of purchase) shall be subject to a \$50.00 deductible for each repair. (After two years, Gravely agrees to repair or replace defective Gravely Products used exclusively for personal, family or household purposes only to the extent that the cost of such warranty covered repair or replacement exceeds \$50.00.)

Batteries are warranted by Gravely for a period of twelve (12) months only. If a battery shall fail within twelve (12) months of purchase, the replacement cost thereof shall be prorated over a twelve-month term based upon the number of months since purchase.
5. To obtain Warranty Service on a Gravely Product (including any battery or other component not manufactured by Gravely), use this procedure:
 - a. Notify the Gravely dealer from whom you purchased the equipment.
 - b. If you have moved and it is not convenient to notify the selling dealer, notify the nearest Gravely dealer. You should supply this dealer with a copy of the bill of sale as proof of the date of purchase.
 - c. Make arrangements to have the equipment delivered to the dealer (refer to paragraph 6 a., below).
 - d. If you have any questions concerning the Gravely Limited Warranty, they should be referred to:

Gravely International, Inc.
One Gravely Lane
Clemmons, NC 27012
Attn: Customer Service Department
 - e. Warranty service on Gravely Products must be performed by an authorized Gravely dealer.
6. This Warranty does not cover the following:
 - a. Transportation to the Gravely dealership. (If the Gravely dealer provides transportation, he will charge for such service.)
 - b. Normal maintenance services and normal replacement of items such as spark plugs, belts, oil, oil filters, air filters, and mower, plow or cultivator blades, gauge wheels, skids and other wear items.
 - c. Any Gravely Product which has been altered or modified in any way.
 - d. Any repair or replacement occasioned by customer neglect or lack of proper maintenance. (The purchaser is responsible for making sure that Gravely Products are operated and serviced as directed in the applicable manual or service instruction. Incorrect use or maintenance will void this Warranty.)
 - e. Any repair occasioned by the use of any attachment not approved by Gravely. (The use of any such unapproved attachment will void this Warranty.)
7. GRAVELY MAKES NO OTHER EXPRESS OR IMPLIED WARRANTIES, OR WARRANTIES AS TO THE MERCHANTABILITY OR FITNESS FOR A PARTICULAR PURPOSE. ALL WARRANTIES ARE LIMITED IN DURATION TO THE TERMS SET OUT IN PARAGRAPH 4, ABOVE. GRAVELY SHALL HAVE NO LIABILITY FOR INCIDENTAL OR CONSEQUENTIAL DAMAGES RESULTING FROM THE BREACH OF ANY WARRANTY, INCLUDING, BUT NOT LIMITED TO, LIABILITY FOR INCONVENIENCE, RENTAL OR PURCHASE OF REPLACEMENT EQUIPMENT, OR FOR LOSS OF PROFITS OR OTHER COMMERCIAL LOSS.
8. Some states do not allow limitations on how long an implied warranty lasts, so the above statement may not apply to you. Some states do not allow the exclusion or limitation of incidental or consequential damages, so the above limitation or exclusion may not apply to you.
9. This Warranty gives you specific legal rights, and you may have other rights which vary from state to state.
10. A Gravely product registration card is supplied with each Gravely Product. Please complete the card and return it to Gravely at the address listed on the card. The equipment registration card will be used by Gravely for:
 - a. Recording date of purchase.
 - b. Notification of owners in compliance with the Consumer Product Safety Act, should any notification be necessary.The return of such card is necessary for your warranty to be effective.
11. This Warranty is not subject to change or modification by anyone, including Gravely dealers and no Gravely dealer is authorized to make any representations or promises on Gravely's behalf.



One Gravely Lane, Clemmons, NC 27012