

# 60" CENTER MOUNT MOWER OPERATOR'S MANUAL

FORM NO. 45794(7-88)

PART NO. 45790

PRINTED IN USA  
\$3.00

## NOTE

Read this manual carefully and learn to operate and service your 60" Rotary Mower before using it.

To keep the warranty, the 60" Rotary Mower must be maintained and operated as directed in this manual.

All references to "left-side", "right-side", "front" and "back" are given from the operator's position.

Use the serial numbers to ensure prompt and correct service when ordering parts, requesting service or making inquiries.

SERIAL NUMBER: \_\_\_\_\_



Look for this symbol to point out important safety precautions. It means -- ATTENTION! BECOME ALERT! YOUR SAFETY IS INVOLVED.

NOTE

## CONTENTS

1. INSTRUCTIONS FOR SAFE OPERATION
2. OPERATING INSTRUCTIONS
3. SERVICE INSTRUCTIONS
4. STORAGE
5. PROBLEM SOLVING
6. ILLUSTRATED PARTS AND PARTS LISTS
7. SPECIFICATIONS
8. SET-UP INSTRUCTIONS
9. WARRANTY

## SECTION 1

### INSTRUCTIONS FOR SAFE OPERATION

Improper use of this equipment can injure people and damage the equipment. People using or servicing this equipment must read and follow the instructions in this manual.

It is important to understand that this manual and any other Gravely instruction manuals do not cover every possible danger. It is impossible for Gravely to know all possible dangers in operating and servicing the equipment.

The purchaser must give these instructions to the people operating and maintaining this equipment. These people must use eye and foot protection.

#### **1.1 Preparation:**

1. Read this manual and the tractor manual carefully.
2. Learn the location and function of all controls.
3. Learn how to use the controls to stop the wheels and mower quickly.
4. Use caution with gasoline. Gasoline is very flammable. Keep it in a clean and tight container away from flames or hot items. Never put gasoline in the fuel tank while the engine is running or hot. Clean up spilled gasoline before starting engine.
5. Be certain that all shield, guards, and interlock switches are in the correct positions.
6. Never permit children to operate the tractor and mower.
7. Inspect area to be mowed and remove all material which could be thrown by the mower.
8. Before starting the engine, put the PTO-control lever in the "OFF" position and the gear shift lever in the neutral "N" position.
9. When hauling the equipment, connect the chassis to the transporting vehicle. Never connect from control levers, rods, or like items that could be damaged.
10. Replace all parts that become damaged or lost.

#### **1.2 Operation:**

1. Wear foot and eye protection. Do not wear loose clothing.
2. Do not use the equipment in the dark without adequate lighting.

SECTION 1

INSTRUCTIONS FOR SAFE OPERATION

3. Keep the equipment in good condition. Maintain it as directed in this manual.
4. USE ONLY GRAVELY ACCESSORIES AND ATTACHMENTS.
5. Do not overspeed the engine. Do not override the governor.
6. Keep away from moving parts.
7. Keep people and animals away from the operating area.
8. Do not let people other than the operator near the operating equipment.
9. Use a slow speed and engage the direction control slowly when operating on slopes.
10. Look for and keep away from hazards.
11. After hitting an object, stop the equipment and engine. Check for damage. Repair any damage before operating.
12. Look behind when operating in reverse. Look for people and hazards.
13. Operate only from the operator's position.
14. Travel up and down slopes, not across.
15. If there is a sudden change in the sound or vibration of the equipment, stop the engine and check for damage. Repair any damage or failure before continuing operation.
16. Never run the engine indoors except to move it outside. Exhaust fumes are dangerous.
17. Go slowly on slick surfaces.
18. Follow traffic laws when operating on or near a road.
19. Before making adjustments or servicing, move the PTO to "OFF", turn the ignition switch to "OFF" and wait until all moving parts completely stop.
20. Before leaving the operator's position, put the PTO lever in the "OFF" position and turn the ignition key to the "OFF" position. Lock the brake lock. Wait until all moving parts have stopped.

## SECTION 2

### OPERATING INSTRUCTIONS

 **CAUTION:** The 60" mower is recommended for use on a Model 8179-G tractor, 8199-G tractor, Professional 16G, 18G or 20G tractors. Mow only with the hydraulic control in the float position.

- 2.1 Transport the equipment to the area to be mowed.
- 2.2 Inspect the area to be mowed and remove all material which could be thrown by the mower.
- 2.3 Plan the pattern for cutting the grass. Generally an area is mowed around the periphery towards the center by discharging the grass toward the center on the first pass. The remainder of the mowing is done discharging the grass outward in the area which has been cut.
- 2.4 See Section 7 for the schedule of heights of cut. Set the mower for the height of cut desired.
- 2.5 See the tractor manual for correct operation of the PTO. Start the engine and put the PTO control in the "ON" position. Move the throttle control to the "FAST" position.
- 2.6 Select a slow gear. Engage the forward clutch. Control the ground speed by selecting the desired gear.

 **CAUTION:** Do not shift the transmission gears while the tractor is moving.

## SECTION 3

### SERVICE INSTRUCTIONS

#### 3.1 Lubrication:

1. See Figures 1, 2 and 3. Every eight hours of operation apply multi-purpose grease to the lube fittings on:
  - a. Each spindle (3)
  - b. Each gauge wheel (4)
  - c. Drive shaft (2)
  - d. Each caster fork (2)
  - e. Each idler pivot weldment (2)
2. Gear Box: Once a year or every 200 hours of operation, check the lubricant by removing the cover. Clean the top of the gear box and carefully remove the cover. Replace the gasket if damaged. Keep the gear box 3/4 full of grease.

#### 3.2 Blade Service:

1. Every ten hours of operation or when the cut is poor visually, check the blades for sharpness.
2. Remove the mower from the tractor. See Sections 3.6 and 3.7.
3. Turn the mower upside down.
4. Block the blades and remove the nuts and flat washers from the spindle.
5. Sharpen and balance the blade.
6. Reverse the removal process to install the blades on mower and the mower on the tractor.
7. Replace the blades when over 1/2" has been removed or the blade cannot be balanced.

#### 3.3 Height of Cut Adjustment:

Lift the mower to the transport position. Remove the bolts in the caster wheel support weldment. Move the caster wheel support weldment to the holes which correspond to the desired height position and reinstall the retaining bolts. See Figure 3.

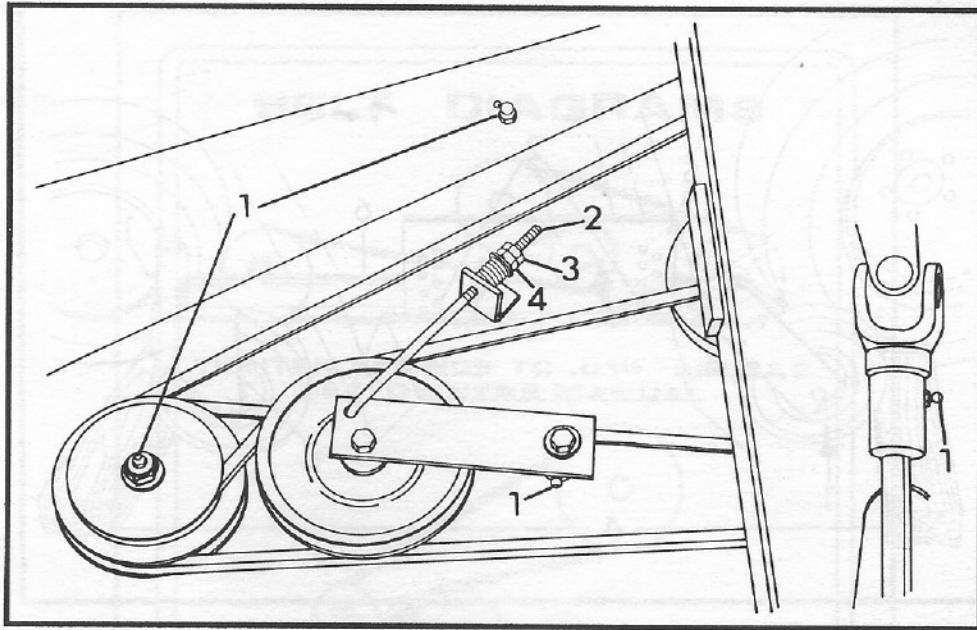

- 1 - Lube Fittings
  - 2 - Idler Rod
  - 3 - Jam Nut
  - 4 - Adjusting Nut
- FIGURE 1

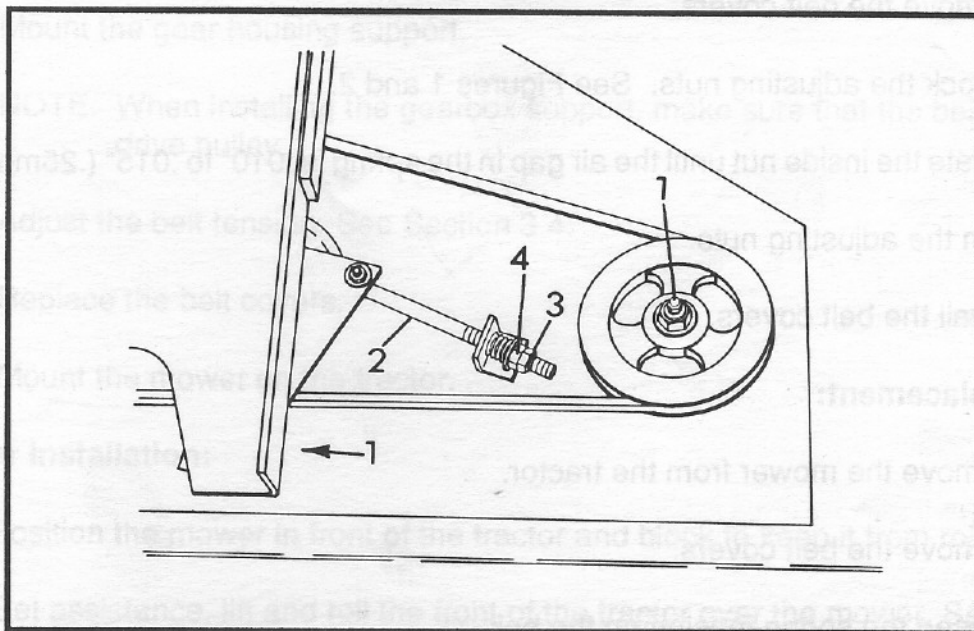

- 1 - Lube Fittings
  - 2 - Idler Rod
  - 3 - Jam Nut
  - 4 - Adjusting Nut
- FIGURE 2



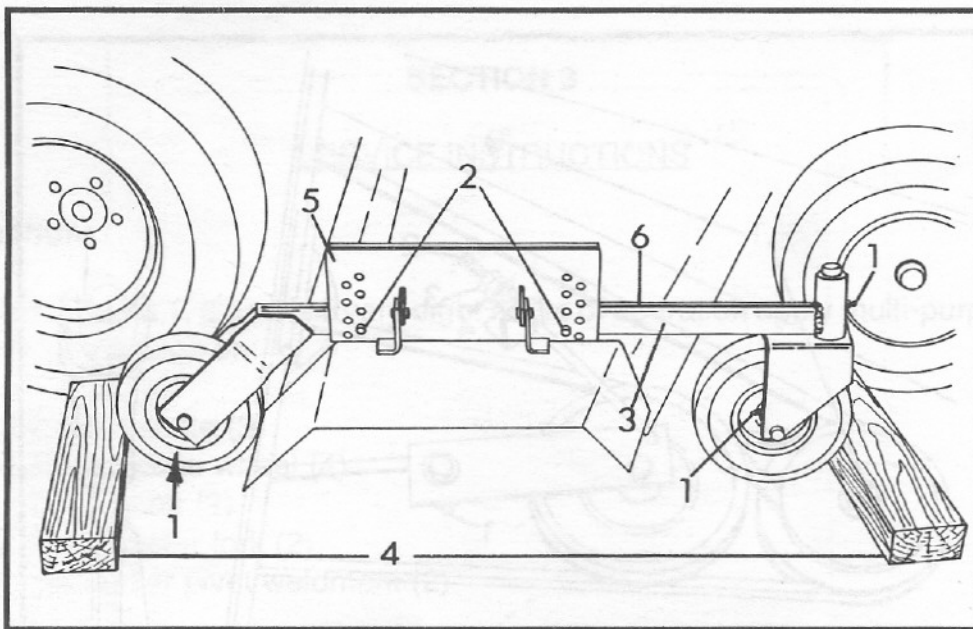

- |                                    |                     |
|------------------------------------|---------------------|
| 1 - Lube Fittings                  | 4 - Blocks          |
| 2 - Height Of Cut Adjustment Bolts | 5 - Hanger Assembly |
| 3 - Caster Wheel Support Weldment  | 6 - Trim Line       |

FIGURE 3

### 3.4 Belt Adjustment:

1. Remove the belt covers.
2. Unlock the adjusting nuts. See Figures 1 and 2.
3. Rotate the inside nut until the air gap in the spring is .010" to .015" (.25mm to .38mm).
4. Jam the adjusting nuts.
5. Install the belt covers.

### 3.5 Belt Replacement:

1. Remove the mower from the tractor.
2. Remove the belt covers.
3. Loosen the spring tension on the belt.
4. Remove the gear housing support.
5. Remove the belts.
6. Put the new belts in position on the sheaves. See Diagram 1.

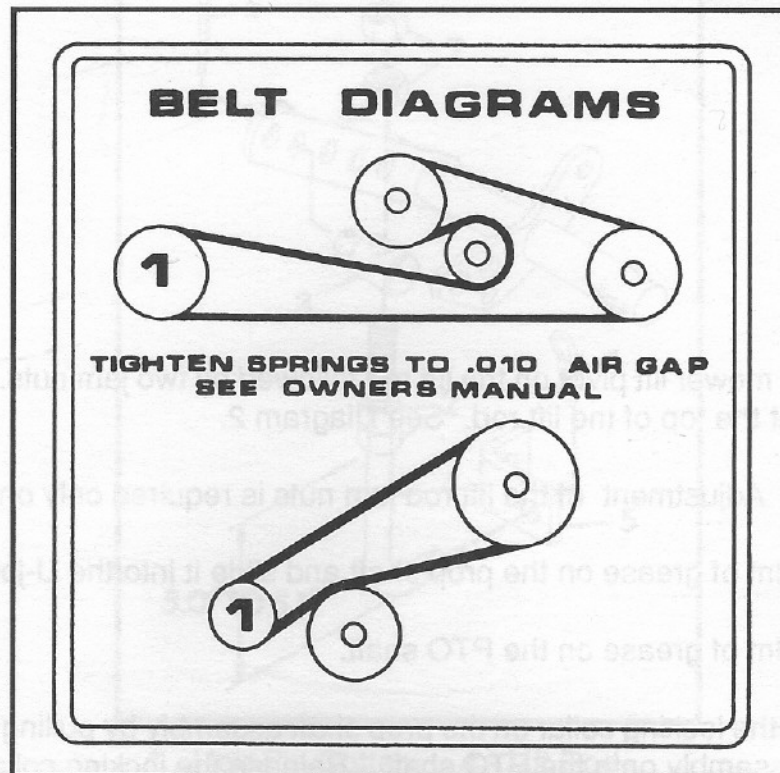

DIAGRAM 1

7. Mount the gear housing support.

NOTE: When installing the gearbox support, make sure that the belt is around the drive pulley.

8. Adjust the belt tension. See Section 3.4.
9. Replace the belt covers.
10. Mount the mower on the tractor.

### 3.6 Mower Installation:

1. Position the mower in front of the tractor and block to keep it from rolling.
2. Get assistance, lift and roll the front of the tractor over the mower. See Figure 3.
3. Align the mower pivot arm weldment with the tractor latch plates. Guide the pivot arm weldment into the latch plates and latch.
4. Put the mower pivot keepers, followed by a flat washer and hairpin cotter on the shaft on each side of the mower pivot arm weldment.

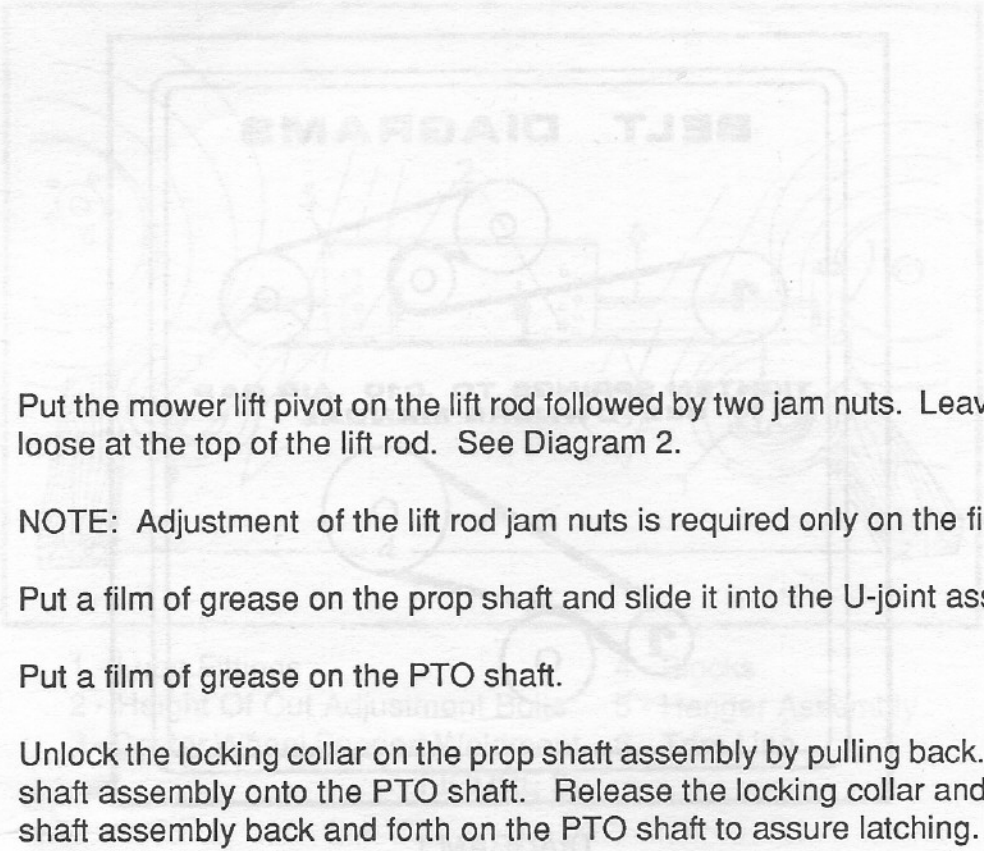
- 
5. Put the mower lift pivot on the lift rod followed by two jam nuts. Leave the jam nuts loose at the top of the lift rod. See Diagram 2.

NOTE: Adjustment of the lift rod jam nuts is required only on the first installation.

6. Put a film of grease on the prop shaft and slide it into the U-joint assembly.
7. Put a film of grease on the PTO shaft.
8. Unlock the locking collar on the prop shaft assembly by pulling back. Slide the prop shaft assembly onto the PTO shaft. Release the locking collar and slide the prop shaft assembly back and forth on the PTO shaft to assure latching.
9. Put the mower in the lowest cutting position. Lower the attachment lift. Connect the lift rod to the mower and the tractor lift. See Diagram 2.
10. Move the top pair of jam nuts down the lift rod until there is approximately 1/8 inches clearance. Jam the top pair of jam nuts.

NOTE: Adjustment of the lift rod jam nuts is required only on the first installation.

11. Lift the mower to the transport position with the attachment lift. Hook the springs to the spring tabs. Pull the latches over the latch pins and lock. See Figure 4.
12. Move the caster wheel support to match the desired height of cut.
13. To remove the mower, reverse the installation procedure.

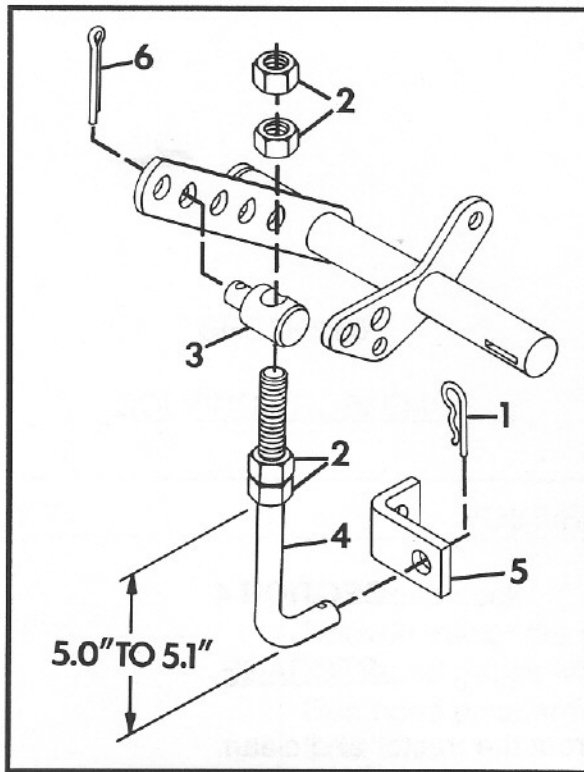

- |                      |                  |
|----------------------|------------------|
| 1 - Hair Pin Cotter  | 4 - Lift Rod     |
| 2 - Jam Nuts         | 5 - Lift Bracket |
| 3 - Mower Lift Pivot | 6 - Cotter Pin   |

DIAGRAM 2

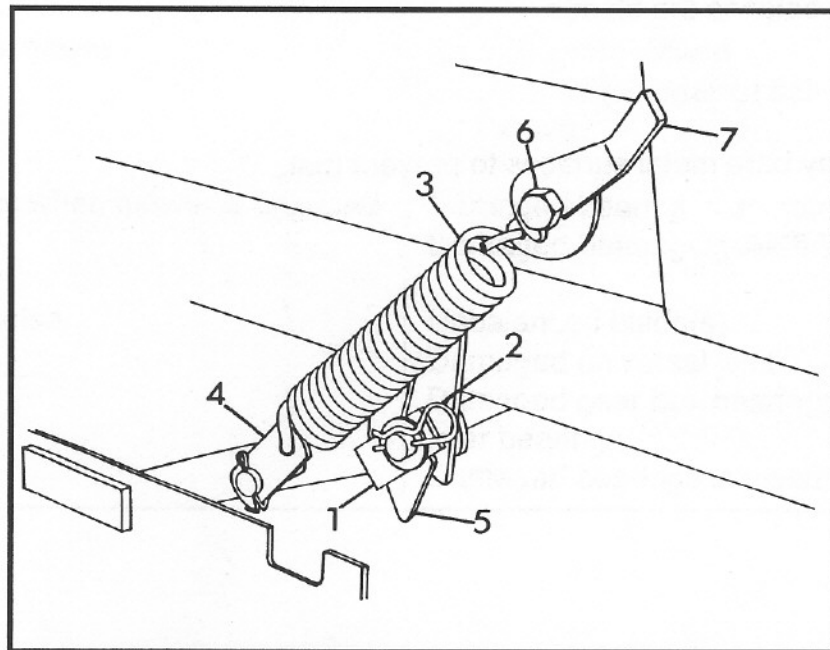

- |                        |                 |
|------------------------|-----------------|
| 1 - Mower Pivot Keeper | 5 - Latch Plate |
| 2 - Hair Pin Cotter    | 6 - Latch Pin   |
| 3 - Extension Spring   | 7 - Latch       |
| 4 - Strap              |                 |

FIGURE 4



## SECTION 4

### STORAGE

- 4.1 Remove the mower from the tractor and clean.

NOTE: Do not use harsh or abrasive cleaners on any painted surface. Do not allow gasoline or oil to remain on any silk screened surface.

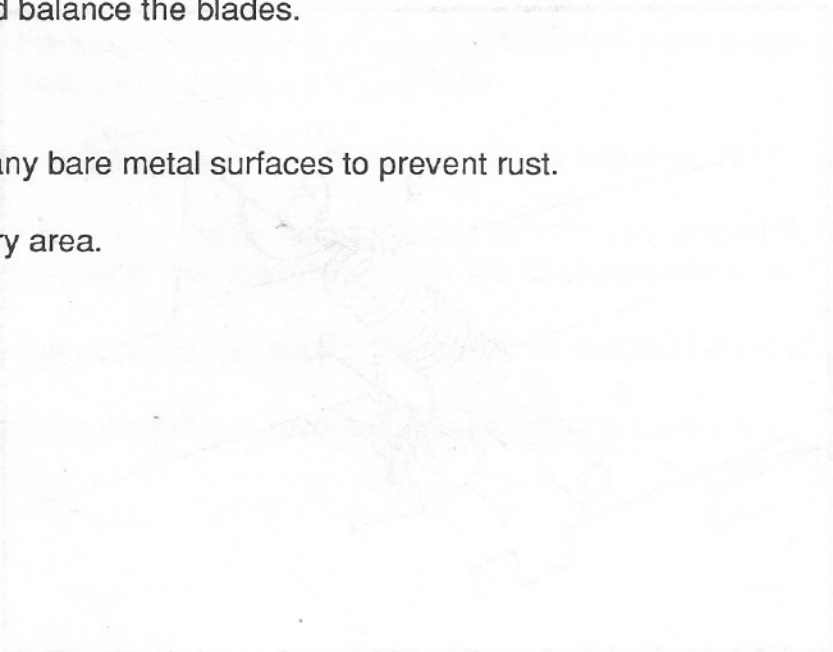
- 4.2 Inspect for damage, wear, loose or missing hardware. Repair as needed.
  - 4.3 Sharpen and balance the blades.
  - 4.4 Lubricate.
  - 4.5 Paint or oil any bare metal surfaces to prevent rust.
  - 4.6 Place in a dry area.
- 

## SECTION 5

### SOLVING PROBLEMS

OBSERVATION	POSSIBLE CAUSE
1. Uneven cut	Damaged deck Uneven tractor tire pressure Damaged gauge wheel or axle Damaged pivot arm weldment Bent blade
2. Uncut grass	Dull blade Damaged blade Too low engine speed Mowing tall grass Tractor ground speed too fast
3. Smoke from mower	Spindle/blade locked Debris wedged against belt Loose belt
4. Engine slows when mower is engaged	Damaged bearing in spindle assembly Damaged bearings/gears in the gear box
5. Excessive noise	Unbalanced blade(s) Damaged universal joint Damaged gear box bearings/gears Idler bearings Damaged bearings in spindle assembly

# SECTION 6

## ILLUSTRATED PARTS AND PARTS LISTS

### Gauge Wheels, Rollers and Height Adjustment

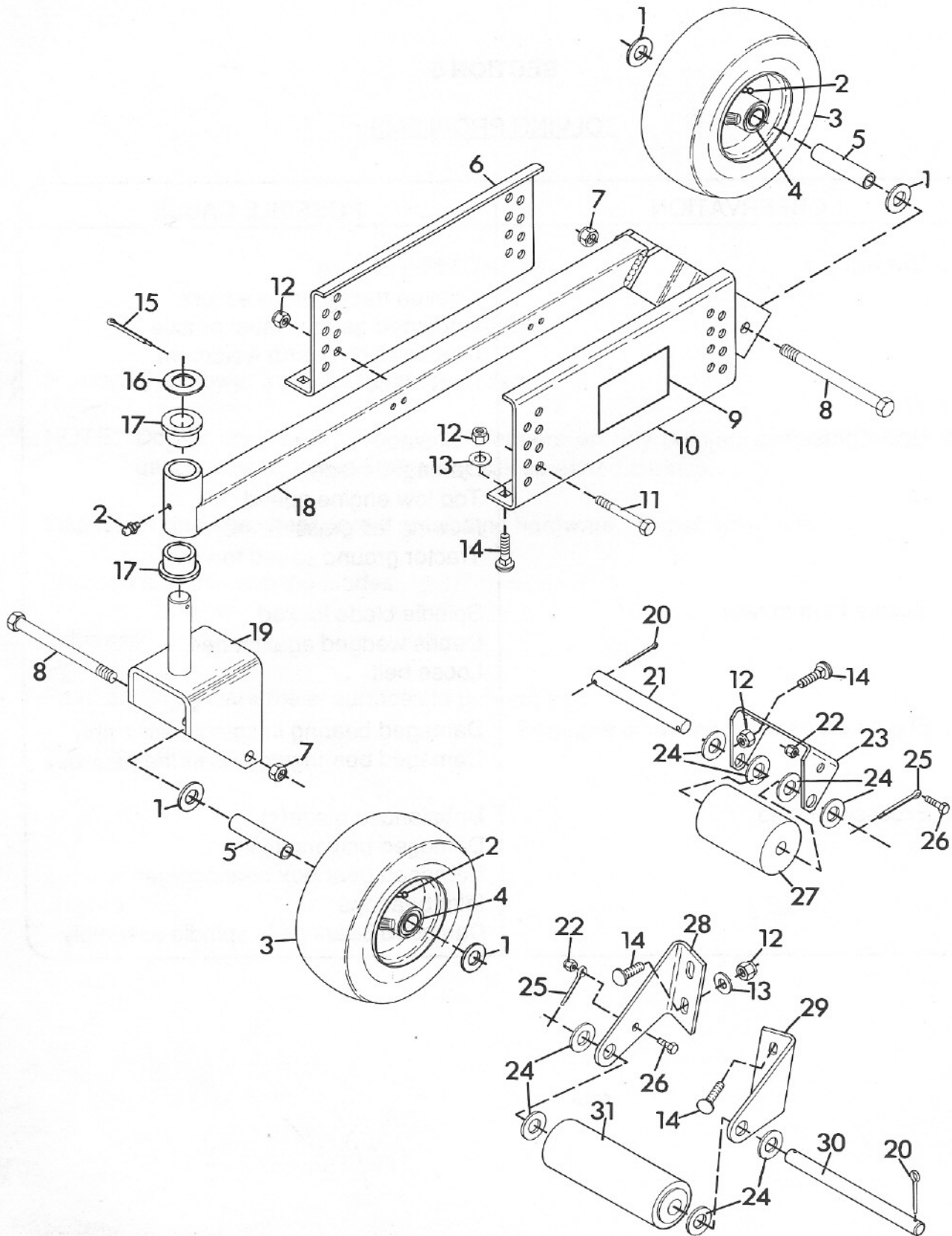

### Gauge Wheels, Rollers and Height Adjustment

ITEM				ITEM			
NO.	PART NO.	QTY.	DESCRIPTION	NO.	PART NO.	QTY.	DESCRIPTION
1	415543	16	Washer, Flat .531x1.250x.100	17	18355	4	Bushing, Pivot
2	411027	3	Fitting, Lube 1/4-28	18	45487	2	Weldment, Caster Wheel Support
3	45205	4	Wheel, Gauge	19	45523	2	Weldment, Caster Fork
4	37823	2	Bearing, Gauge Wheel	20	179128	3	Pin, Cotter .25x1.00
5	11950	4	Bushing, Wheel	21	45211	1	Rod
6	45510	1	Hanger, L.H.	22	120375	3	Nut, Hex 1/4-20
7	435507	4	Nut, Lock 1/2-13	23	45210	1	Bracket, Roller
8	433163	4	Bolt, Hex 1/2-13x5.00	24	131016	12	Washer, Flat .656x1.312x.095
9	33927	1	Decal, Danger Foot	25	103422	3	Pin, Cotter .250x2.00
10	45509	1	Hanger, R.H.	26	180020	3	Bolt, Hex 1/4-20x.75
11	180134	4	Bolt, Hex 3/8-16x2.50	27	15351	1	Roller, Gauge
12	456004	16	Nut, Lock 3/8-16	28	45567	1	Bracket, Roller L.H.
13	120394	10	Washer, Flat .406x.812x.065	29	45568	1	Bracket, Roller R.H.
14	120915	12	Bolt, 3/8-16x1.00 Rd Hd Sq Nk	30	24795	2	Shaft, Center Roller
15	137253	2	Pin, Cotter .187x1.625	31	31390	2	Roller, Gauge
16	19340	2	Race, Bearing Thrust				



# Mower Deck

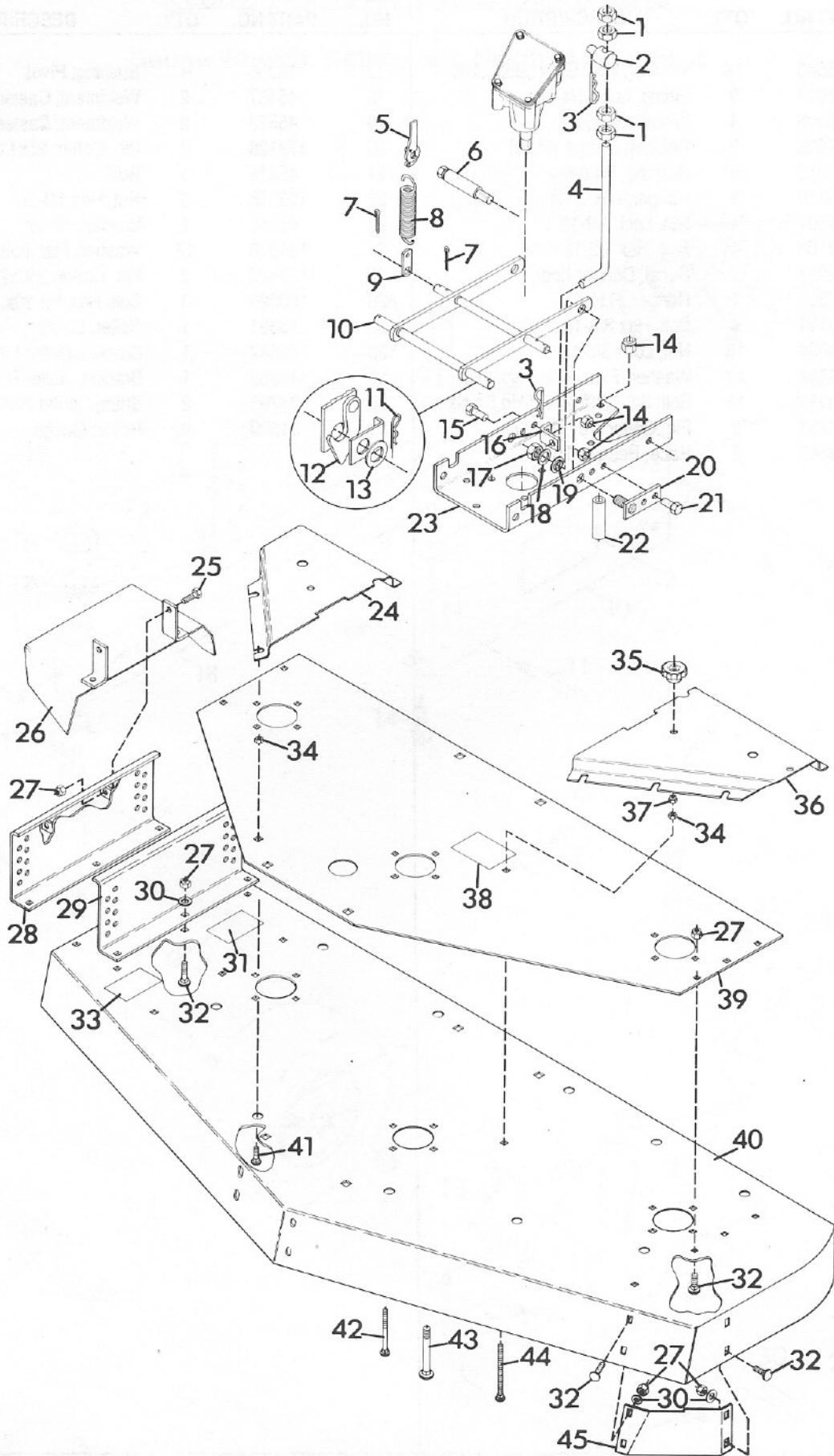

### Mower Deck

ITEM NO.	PART NO.	QTY.	DESCRIPTION	ITEM NO.	PART NO.	QTY.	DESCRIPTION
1	120238	4	Nut, Jam 1/2-13 Hex	24	40534	1	Cover, Belt R.H.
2	40625	1	Pivot, Mower Lift	25	180124	2	Bolt, Hex 3/8-16x1.25
3	15691	2	Pin, Cotter Hair	26	35668	1	Weldment, Discharge Chute
4	40815	1	Rod, Lift	27	456004	16	Nut, Lock 3/8-16
5	40309	1	Latch, Spring Assembly R.H.	28	45573	1	Weldment, 60" Hanger
	40311	1	Latch, Spring Assembly L.H.	29	45510	1	Hanger, L.H.
6	31688	2	Latch, Pin	30	120394	10	Washer, Flat .406x.812x.065
7	120123	4	Pin, Cotter .125x1.25	31	33926	1	Decal, Danger Hand
8	11272	2	Spring, Ext. 7.625x1.50x.70 Rate	32	120915	14	Bolt, 3/8-16x1.00 Rd Hd Sq Nk
9	11273	2	Strap	33	33928	1	Decal, Warning Eye
10	40512	1	Weldment, Pivot Arm	34	124824	13	Nut, Jam 5/16-18 Hex
11	10405	2	Pin, Hair	35	41674	3	Knob
12	37982	2	Keeper, Mower Pivot	36	40535	1	Cover, Belt L.H.
13	423315	AR	Washer, Flat .813x1.37x.100	37	419455	3	Nut, Lock 5/16-18
14	435507	8	Nut, Lock 1/2-13	38	31834	1	Decal, Belt Diagram
15	180179	1	Bolt, Hex 1/2-13x1.75	39	40536	1	Plate, Deck Support
16	40816	1	Bracket, Lift	40	45546	1	Weldment, 60" Deck
17	34112	2	Nut, Lock 3/4-10	41	126358	10	Bolt, Carriage 5/16-18x1.00
18	11223	2	Race, Bearing Thrust	42	40193	1	Bolt, Hex 5/16-18x3.50
19	10174	2	Bushing, Nylon 76x1.0x.6 Flg.	43	126803	4	Bolt, 1/2-13x3.50 Rd Hd Sq Nk
20	37987	2	Weldment, Pivot Anchor	44	40546	2	Bolt, 5/16-16x4.0 Rd Hd Sq Nk
21	180177	3	Bolt, Hex 1/2-13x1.50	45	31354	1	Baffle, Front
22	31367	4	Spacer, .850x.546x2.18	NS	38769	1	Stripe
23	40511	1	Plate, Support				

# Mower Drive

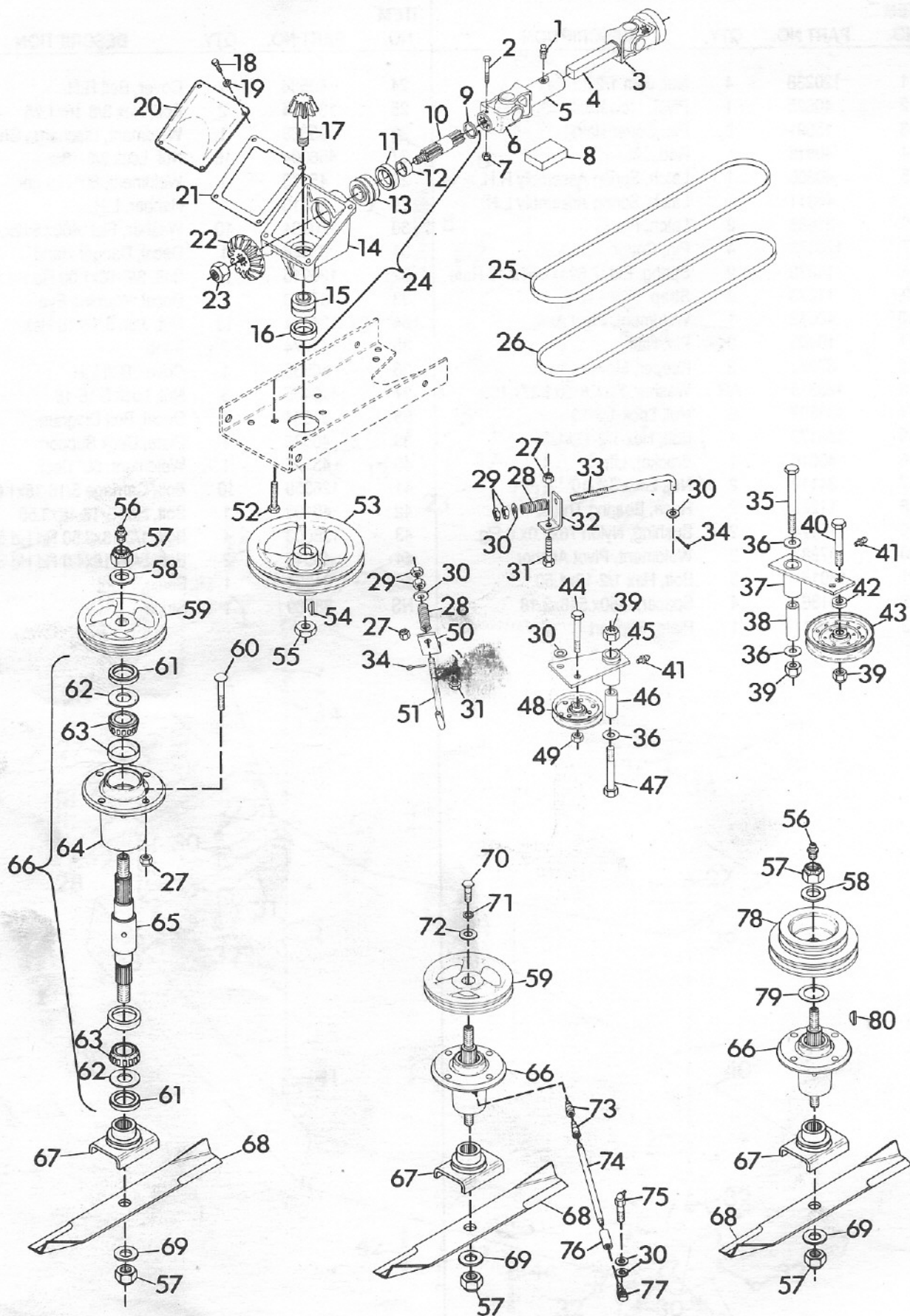

### Mower Drive

ITEM NO.	PART NO.	QTY.	DESCRIPTION	ITEM NO.	PART NO.	QTY.	DESCRIPTION
1	411027	1	Fitting, Lube 1/4-28	52	180173	3	Bolt, Hex 1/2-13x1.00
2	180046	1	Bolt, Hex 1/4-20x2.25	53	31382	1	Pulley, Gear Box
3	45954	AR	Yoke	54	431787	1	Key, Woodruff 3/16x5/8 No. 61
4	31389	1	Shaft, Prop. Sq. Bar	55	451539	1	Nut, Jam 3/4-10 Hex Heavy
5	31388	1	U-Joint, Female	56	411010	2	Fitting, Lube 1/8
6	46088	AR	Yoke	57	418692	5	Nut, Lock 5/8-11
7	419454	1	Nut, Lock 1/4-20	58	33845	2	Washer, Flat .687x1.312x.122
8	24560	1	Kit, Repair U-Joint	59	31359	2	Pulley
	31828	1	Kit, Repair U-Joint	60	126406	12	Bolt, 3/8-16x1.375 Rd Hd Sq Nk
9	14642	1	Ring, Retaining 1.000 Shaft	61	21211		Seal, Steel
10	31412	1	Shaft				2 (Right and Center Spindles)
11	14646	1	Seal, Oil				1 (Left Spindle)
12	14641	1	Spacer	62	20743		Washer, Flat .975x1.970x.030
13	14640	1	Assembly, Bearing				2 (Right and Center Spindles)
14	14636	1	Casting, Gear Box				1 (Left Spindle)
15	14644	1	Assembly, Bearing	63	38199	2	Assembly, Bearing
16	14645	1	Seal, Oil	64	21215		Housing, Bearing
17	<del>45588</del>	1	Shaft, Gear Pinion <i>51326</i>				1 (Left and Right Spindle)
18	180016	4	Bolt, Hex 1/4-20x.50		21218		Housing, Bearing
19	120380	4	Washer, Lock 1/4 Reg.				1 (Center Spindle)
20	10982	1	Cover, Gear Housing	65	21216		Shaft, Spindle
21	11231	1	Gasket, Gear Housing				1 (Right Spindle)
22	<del>45587</del>	1	Gear, Bevel <i>51325</i>		31356		Shaft, Spindle
23	456007	1	Nut, Lock 3/4-10		34603		1 (Center Spindle)
24	31410	1	Assembly, Drive				Shaft, Spindle
25	31369	1	Belt, "A"				1 (Left Spindle)
26	31383	1	Belt, "B"	66	21306		Assembly, Spindle
27	456004	14	Nut, Lock 3/8-16				1 (Right Spindle)
28	11779	2	Spring, Comp. 1x.78x338		35646		Assembly, Spindle
29	120369	4	Nut, Hex 3/8-24				1 (Center Spindle)
30	120394	6	Washer, Flat .406x.812x.065		34605		Assembly, Spindle
31	180122	2	Bolt, Hex 3/8-16x1.00				1 (Left Spindle)
32	31346	1	Support, Spring "B"	67	23026	3	Weldment, Blade Cradle
33	21111	1	Rod, Idler	68	25124	3	Blade
34	179252	2	Pin, Cotter .06x1.00	69	131016	3	Washer, Flat .656x1.312x.095
35	180193	1	Bolt, Hex 1/2-13x3.75	70	22065	1	Bolt, Hex Special 1/2-13x1.34
36	120389	3	Washer, Flat .500x1.250x.083	71	120384	1	Washer, Lock 1/2 Reg.
37	31360	1	Weldment, Idler Pivot "B"	72	37842	1	Washer, Flat 1.38x.56 Hard
38	31363	1	Spacer, .850x.546x2.50	73	144117		Elbow, Street 1/8-26
39	435507	3	Nut, Lock 1/2-13				2 (Center Spindle)
40	180181	1	Bolt, Hex 1/2-13x2.00	74	31357	1	Nipple, Pipe 6.30
41	14406	2	Fitting, Lube 1/4-28	75	273351	1	Fitting, Lube 65 Degree
42	31368	1	Spacer, .516x.875x.300	76	144067	1	Coupling, Pipe 1/8-27
43	22063	1	Pulley, Flat Idler	77	191759	1	Elbow, Adaptor 90 Degree
44	180128	1	Bolt, Hex 3/8-16x1.75	78	35015	1	Pulley, Drive
45	31364	1	Weldment, Idler Pivot "A"	79	19340	1	Race, Bearing Thrust
46	31367	1	Spacer, .850x.546x2.18	80	124553	1	Key, Woodruff .25x1.00 Hard #15
47	126803	1	Bolt, 1/2-13x3.50 Rd Hd Sq Nk	NS	36799	AR	Spring
48	21060	1	Sheave, Idler	NS	36800	AR	Collar, Locking
49	413534	1	Nut, Lock 3/8-16	NS	36801	AR	Ring, Snap
50	31345	1	Support, Spring "A"	NS	145643	AR	Ball, Detent
51	21112	1	Rod, Idler				

## SECTION 7

### SPECIFICATIONS

Width of Cut: 60 in. (1524mm)

Heights of Cut:

<u>Position</u>	<u>Height of cut</u>
1	1.0 inches (25.4mm)
2	1.5 inches (38.1mm)
3	2.0 inches (50.8mm)
4	2.5 inches (63.5mm)
5	3.0 inches (76.2mm)
6	3.5 inches (88.9mm)
7	4.0 inches (101.6mm)
8	4.5 inches (114.3mm)

Mower Deck Construction: 10-gauge welded and bolted steel construction with a 3/16 in. (4.8 mm) thick reinforcing support plate

Blades:        Number        3  
                  Description        20-1/2 in. (521 mm) long; 1/4 in. (6.4 mm) thick high lift, heat-treated alloy steel

Spindle Assemblies: 1 in. (25 mm) diameter spindle shafts, turning on tapered roller bearings, mounted in cast-iron spindle housings

Discharge: Right side, folding discharge chute

Drive: Telescoping universal joint from PTO to right angle, aluminum alloy gearbox with bevel gears and tapered roller bearings. First spindle is driven by adjustable, spring-tensioned "B" section V-belt. Drive between spindles is adjustable, spring-tensioned "A" section V-belt.

Tires:	Size	9x3.50-4
	Pressure	35-40 PSI (241-276 KN/m <sup>2</sup> )
	Description	pneumatic with 3/4 in. (19mm) ball bearings and grease fittings.
Weight:		362 lbs. (165 kg)
Length:		40 in. (1016mm)
Width:	Chute Down	70.5 in. (1791mm)
	Chute Up	64.3 in. (1633mm)
Height:		15 in. (381mm)

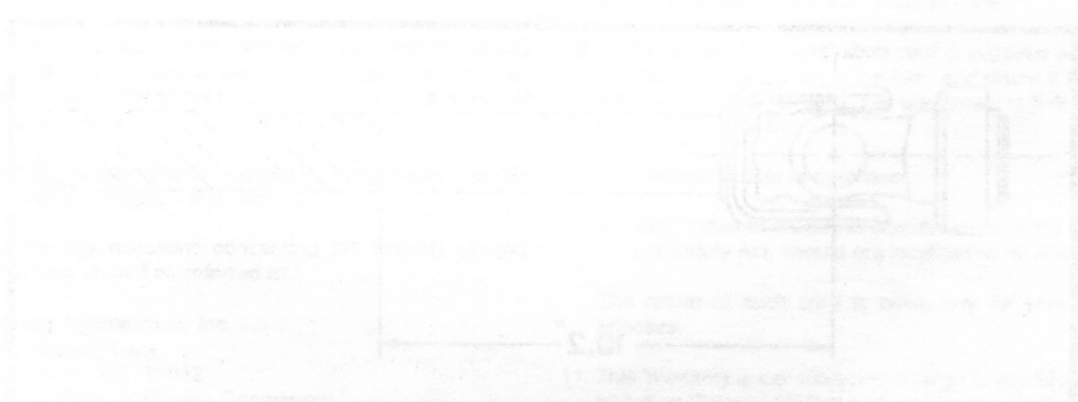

## SECTION 8

### SET-UP INSTRUCTIONS

- 8.1 Remove the mower from the shipping container. Block the mower approximately six inches above the floor.
- 8.2 If needed, loosen the bolts which retain the mower hangers enough to set the caster wheel support assemblies between the hangers. See Figure 3.
- 8.3 Set the right caster wheel support (the one with the stripe) on the right side and the remaining assembly on the left.
- 8.4 Tighten the bolts which retain the mower hangers.
- 8.5 Move the caster wheel support assemblies to the lowest height of cut position. Retain with two bolts each.
- 8.6 Service the mower as described in Section 3.
- 8.7 Put a jam nut on the lift rod until it is 5" to 5.1" from the bottom of the lift rod. Jam a second jam nut against the first nut. See Diagram 2.
- 8.8 Cut off the prop shaft as shown in Diagram 3.
- 8.9 Adjust the tire pressure in the gauge wheels to 35 to 40 psi (240 to 276 kN/m<sup>2</sup>).
- 8.10 See Section 3.6 for mower installation.

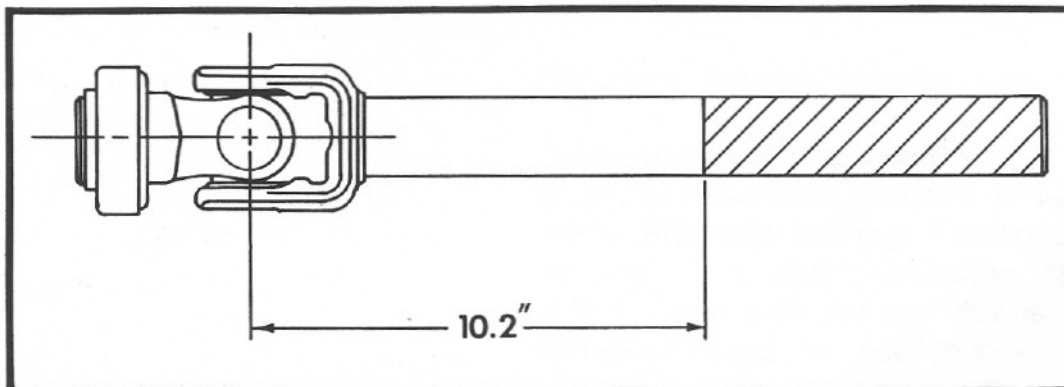

DIAGRAM 3

## SECTION 9

### LIMITED FIVE-YEAR WARRANTY

1. This Limited Five-Year Warranty is issued by Gravely International, Inc., only to the original purchaser. If Gravely equipment is leased by Gravely, this Warranty shall extend also to the original lessee as if such lessee were the original purchaser.
2. Gravely warrants that all new equipment manufactured by Gravely ("Gravely Products") shall be free of defects in material and workmanship for the term described in paragraph 4, below. Except as hereinafter provided, this Warranty does not cover any engine, tires or battery forming a part of the Gravely Product. Engine and tires are covered by and subject to separate warranties of the manufacturers thereof.
3. In the event that any Gravely Product warranted hereunder shall be defective or fail to conform with this Warranty, Gravely shall, subject to the provisions hereof, pay for, or provide labor and materials for, the repair or replacement of such defective Gravely Product.
4. This Warranty is for five years (60 months) from purchase date for Gravely Products used exclusively for personal, family or household purposes, and two years (24 months) for products used for other purposes (commercial use), excluding rental firms. Gravely products used for rental purposes will be warranted for 90 days. Repair of Gravely Products after the second year (24 months from date of purchase) shall be subject to a \$50.00 deductible for each repair. (After two years, Gravely agrees to repair or replace defective Gravely Products used exclusively for personal, family or household purposes only to the extent that the cost of such warranty covered repair or replacement exceeds \$50.00.)

Batteries are warranted by Gravely for a period of twelve (12) months only. If a battery shall fail within twelve (12) months of purchase, the replacement cost thereof shall be prorated over a twelve-month term based upon the number of months since purchase.
5. To obtain Warranty Service on a Gravely Product (including any battery or other component not manufactured by Gravely), use this procedure:
  - a. Notify the Gravely dealer from whom you purchased the equipment.
  - b. If you have moved and it is not convenient to notify the selling dealer, notify the nearest Gravely dealer. You should supply this dealer with a copy of the bill of sale as proof of the date of purchase.
  - c. Make arrangements to have the equipment delivered to the dealer (refer to paragraph 6 a., below).
  - d. If you have any questions concerning the Gravely Limited Warranty, they should be referred to:

Gravely International, Inc.  
One Gravely Lane  
Clemmons, NC 27012  
Attn: Customer Service Department
  - e. Warranty Service on Gravely Products must be performed by an authorized Gravely dealer.
6. This Warranty does not cover the following:
  - a. Transportation to the Gravely dealership. (If the Gravely dealer provides transportation, he will charge for such service.)
  - b. Normal maintenance services and normal replacement of items such as spark plugs, belts, oil, oil filters, air filters, and mower, plow or cultivator blades, gauge wheels, skids and other wear items.
  - c. Any Gravely Product which has been altered or modified in any way.
  - d. Any repair or replacement occasioned by customer neglect or lack of proper maintenance. (The purchaser is responsible for making sure that Gravely Products are operated and serviced as directed in the applicable manual or service instruction. Incorrect use or maintenance will void this Warranty.)
  - e. Any repair occasioned by the use of any attachment not approved by Gravely. (The use of any such unapproved attachment will void this Warranty.)
7. GRAVELY MAKES NO OTHER EXPRESSED OR IMPLIED WARRANTIES, OR WARRANTIES AS TO THE MERCHANTABILITY OR FITNESS FOR A PARTICULAR PURPOSE. ALL WARRANTIES ARE LIMITED IN DURATION TO THE TERMS SET OUT IN PARAGRAPH 4, ABOVE. GRAVELY SHALL HAVE NO LIABILITY FOR INCIDENTAL OR CONSEQUENTIAL DAMAGES RESULTING FROM THE BREACH OF ANY WARRANTY, INCLUDING, BUT NOT LIMITED TO, LIABILITY FOR INCONVENIENCE, RENTAL OR PURCHASE OF REPLACEMENT EQUIPMENT, OR FOR LOSS OF PROFITS OR OTHER COMMERCIAL LOSS.
8. Some states do not allow limitations on how long an implied warranty lasts, so the above statement may not apply to you. Some states do not allow the exclusion or limitation of incidental or consequential damages, so the above limitation or exclusion may not apply to you.
9. This Warranty gives you specific legal rights, and you may have other rights which vary from state to state.
10. A Gravely product registration card is supplied with each Gravely Product. Please complete the card and return it to Gravely at the address listed on the card. The equipment registration card will be used by Gravely for:
  - a. Recording date of purchase.
  - b. Notification of owners in compliance with the Consumer Product Safety Act, should any notification be necessary.The return of such card is necessary for your warranty to be effective.
11. This Warranty is not subject to change or modification by anyone, including Gravely dealers and no Gravely dealer is authorized to make any representations or promises on Gravely's behalf.

 **GRAVELY**

One Gravely Lane, Clemmons, NC 27012