



**5000 SERIES TRACTOR
ILLUSTRATED PARTS LIST**

TABLE OF CONTENTS

	<u>Page</u>
Transmission	1
Standard Differential, Model 5200	4
Swiftamatic Differential, Models 5240, 5260, 5645, 5665 .	6
Wheels	9
Frame, Models 5200 and 5240	10
Frame, Models 5260, 5645, and 5665	12
Controls	14
Fuel System and Exhaust	16
Electrical	18

TRANSMISSION

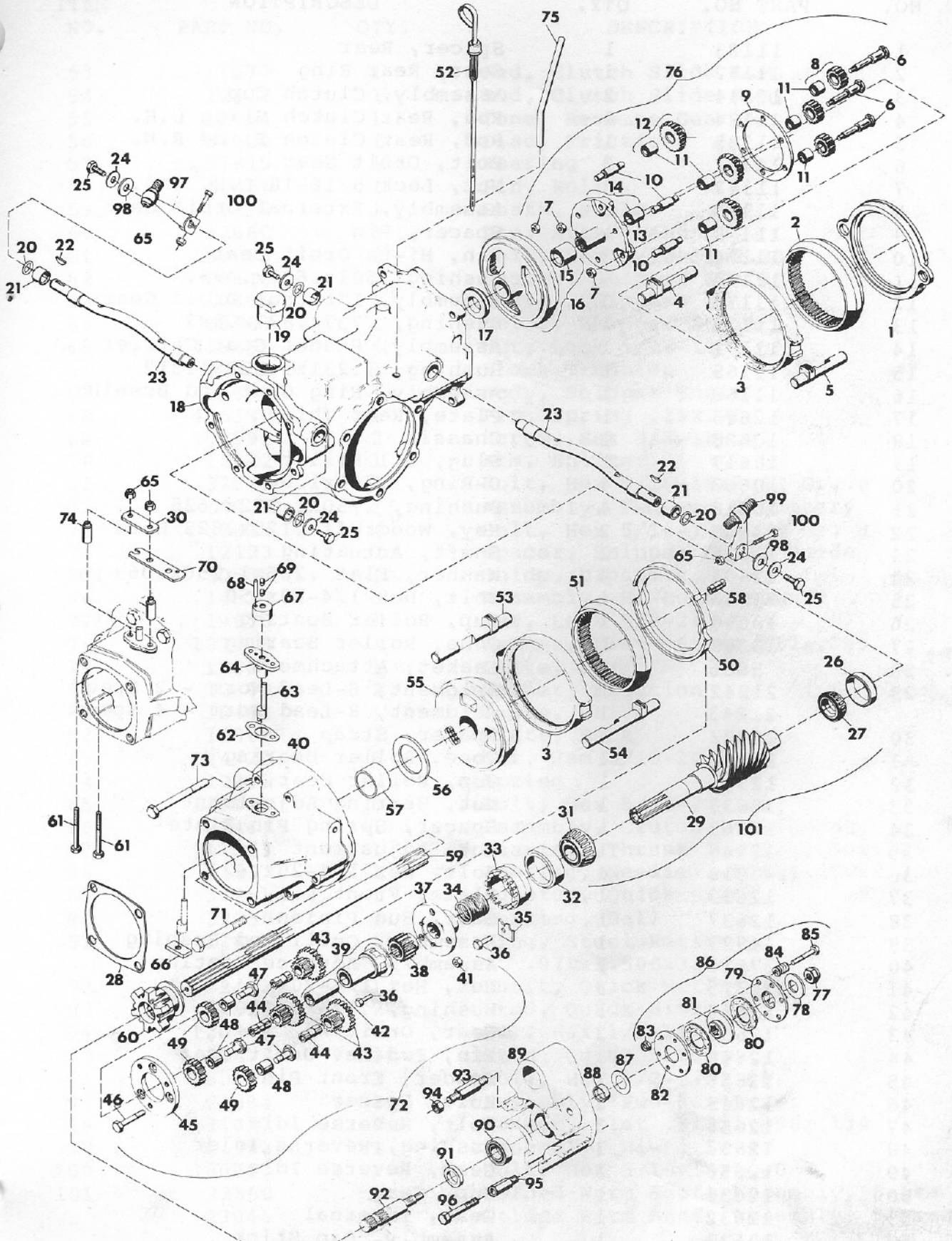

TRANSMISSION

ITEM NO.	PART NO.	QTY.	DESCRIPTION
1	11183	1	Spacer, Rear
2	11182	1	Gear, Rear Ring
3	12644	2	Assembly, Clutch Cup
4	11184	1	Rod, Rear Clutch Slide L.H.
5	11185	1	Rod, Rear Clutch Slide R.H.
6	11181	3	Bolt, Orbit Gear
7	11342	3	Nut, Lock 5/16-18 L.H. Thd.
8	11179	3	Assembly, External Orbit Gear
9	11178	1	Spacer, Pin
10	11174	3	Pin, Hi-Lo Orbit Gear
11	11177	6	Bushing .501x.627x.495
12	11175	3	Assembly, Internal Orbit Gear
13	11172	1	Bushing, .737x.877x.682
14	11171	1	Assembly, Planet Gear Carrier
15	11169	1	Bushing, 1.231x1.502x1.312
16	11168	1	Assembly, Ring Gear and Bushing
17	12645	1	Plate, Rear Thrust
18	10628	1	Chassis
19	10617	1	Plug, Oil Filler
20	10663	4	O-Ring, .750x1.00
21	10618	4	Bushing, .750x1.002x.625
22	124545	2	Key, Woodruff .125x.625 Hard
23	10625	2	Shaft, Actuating
24	12694	4	Washer, Flat .265x1.250x.063
25	180016	4	Bolt, Hex 1/4-20x.50
26	10390	1	Cup, Roller Bearing
27	10389	1	Cone, Roller Bearing
28	5056	1	Gasket, Attachment
29	21242	1	Weldment, 6-Lead Worm - 2 Speed
	21243	1	Weldment, 8-Lead Worm - 4 Speed
30	20822	1	Spacer, Strap
31	12332	1	Cone, Roller Bearing
32	12333	1	Cup, Roller Bearing
33	12635	1	Nut, Bearing Adjustment
34	12663	1	Spacer, Spring Pin Plate
35	12648	1	Nut, Adjustment
36	180018	4	Bolt, Hex 1/4-20x.625
37	12633	1	Plate, Front Pin
38	12637	1	Gear, Sun Pinion
39	14923	1	Assembly, Quill and Bushing
40	37821	1	Assembly, Advance Casting
41	120375	3	Nut, Hex 1/4-20
42	12662	1	Bushing, .875x1.000x2
43	12639	3	Gear, Orbit
44	12640	3	Pin, Fwd-Rev Orbit Gear
45	12655	1	Spacer, Front Pin
46	12643	3	Bolt, Spacer
47	12658	3	Bolt, Reverse Idler
48	12657	3	Bushing, Reverse Idler
49	12656	3	Gear, Reverse Idler
50	12636	1	Cup, Gear
51	12632	1	Gear, Internal
52	10622	1	Assembly, Dip Stick

TRANSMISSION

ITEM NO.	PART NO.	QTY.	DESCRIPTION
53	12677	1	Rod, Clutch Slide L.H.
54	12678	1	Rod, Clutch Slide R.H.
55	12654	1	Cone, Reverse Gear
56	37820	1	Disc, Friction
57	37819	1	Bearing
58	13456	1	Pin, Roll
59	11298	1	Shaft, Pinion
60	12660	1	Dog, Attachment
61	180089	2	Bolt, Hex 5/16-18x2.25
62	18318	1	Gasket, Shipper Shaft
63	10686	1	Shaft, Shipper
64	10687	1	Guide, Shipper Shaft
65	419455	4	Nut, Lock 5/16-18
66	12601	1	Block Trunnion
67	10688	1	Body, Shipper Shaft
68	456390	1	Pin, Spring .25x.75
69	102591	2	Screw, Set 3/8-16x.25
70	12122	1	Arm, Shifter
71	37817	2	Bolt, Hex 5/16-18x3.50 Gr. 8
72	14922	1	Assembly, Fwd-Rev Planetary
73	37818	4	Bolt, Hex 5/16-18x3.25 Gr. 8
74	12123	2	Spacer, Shipper Shaft Guide
75	10586	1	Guide, Dipstick
76	14615	1	Assembly, Hi-Lo Planetary
77	19918	1	Nut, Lock 5/8-24
78	131016	1	Washer, Flat .656x1.312x.095
79	12867	1	Plate, Dog
80	12870	2	Washer, Friction
81	22480	1	Plate, Drive
82	12868	1	Plate, Back
83	124920	6	Nut, Jam 5/16-24
84	12871	6	Spring
85	181618	6	Bolt, Hex 5/16-24x1.75
86	22484	1	Assembly, Clutch Attachment
87	11983	1	Bearing, Thrust 1.012x1.750x.125
88	11227	1	Bearing, Needle 1.000x1.250x2.000
89	34761	1	Adaptor, Quick Hitch
90	32050	1	Bearing, Ball
91	11841	1	Ring, Steel Retaining .978x1.500x3.00
92	22482	1	Shaft, Quick Hitch
93	24824	2	Stud, Quick Hitch
94	120378	2	Nut, Hex 1/2-13
95	22479	2	Stud, Quick Hitch
96	180173	2	Bolt, Hex 1/2-13x1.00
97	21384	1	Assembly, Fwd-Rev Lever
98	131017	4	Washer, Flat .812x1.496x.134
99	21383	1	Assembly, Hi-Lo Lever
100	180087	2	Bolt, Hex 5/16-18x2.00
101	22560	1	Welded Worm Shaft Assembly, 6-Lead
	23046	1	Welded Worm Shaft Assembly, 8-Lead

STANDARD DIFFERENTIAL, MODEL 5200

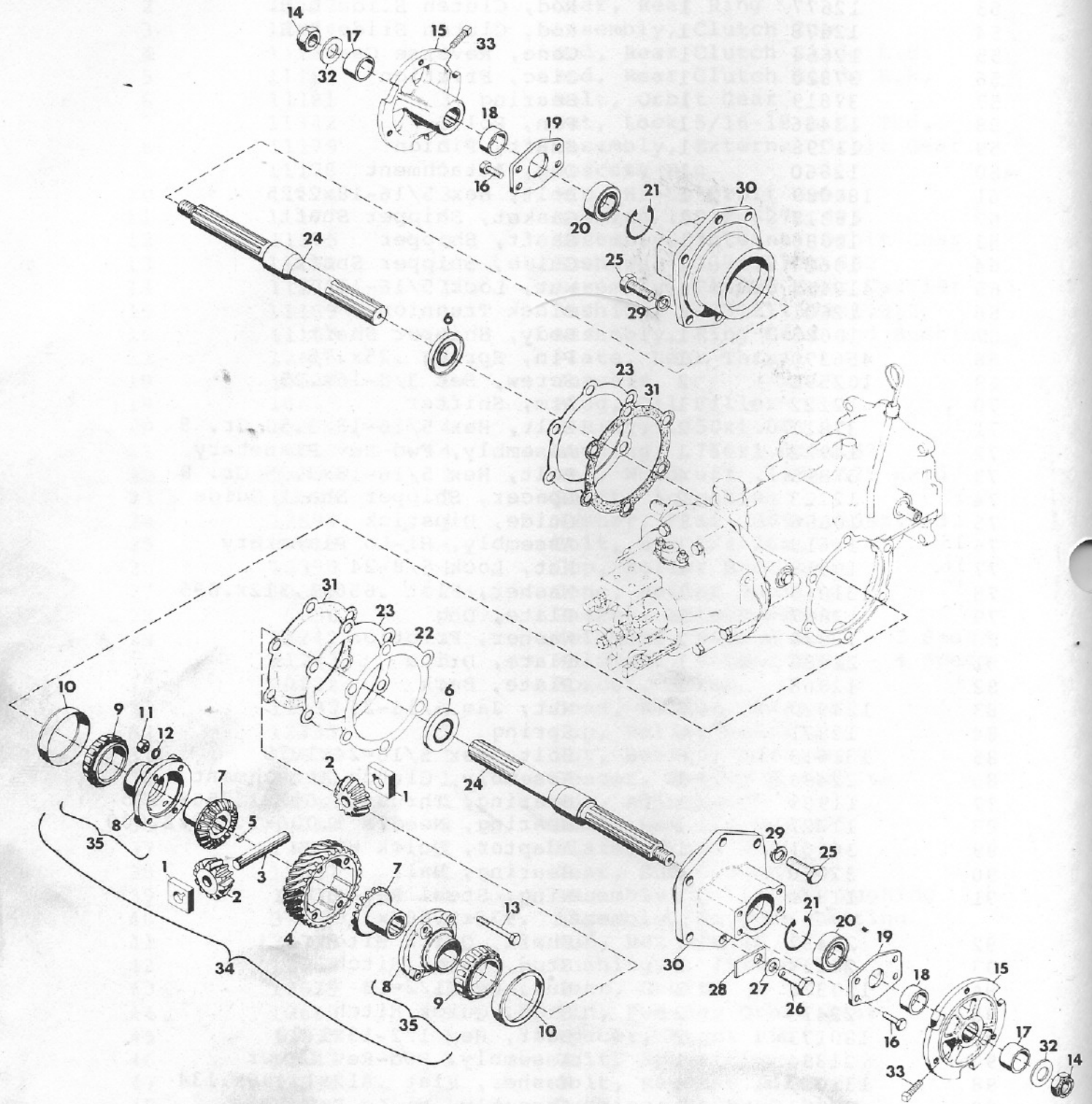

STANDARD DIFFERENTIAL, MODEL 5200

ITEM NO.	PART NO.	QTY.	DESCRIPTION
1	22505	2	Block, Drive
2	6708	2	Gear, Spider Bevel
3	12556	1	Pin, Spider Pinion
4	13498	1	Gear, 6 Start Worm
5	271089	1	Key, Woodruff .125x.375 Hard
6	22506	2	Seal, Oil 1.188x2.000x.250
7	6709	2	Gear, Differential Bevel
8	22504	2	Housing, Differential
9	12131	2	Cone, Roller Bearing
10	12130	2	Cup, Roller Bearing
11	120368	4	Nut, Hex 5/16-24
12	138538	4	Washer, Lock 5/16 Int. Tooth
13	181623	4	Bolt, Hex 5/16-24x2.75
14	22502	2	Nut, Hex 3/4-10 Light Thin
15	22507	2	Hub, Wheel
16	180120	8	Bolt, Hex 3/8-16x.750
17	22512	2	Spacer
18	22501	2	Spacer
19	22503	2	Plate, End
20	32050	2	Bearing, Ball 1.000x2.000x.562
21	22497	2	Ring, Retaining 2.000 Bore
22	12596	AR	Shim, Axle Housing .020
23	12595	AR	Shim, Axle Housing .005
24	22493	2	Axle, Straight
25	180173	11	Bolt, Hex 1/2-13x1
26	13624	1	Bolt, Hex 1/2-13x1 Nylon Insert
27	120396	1	Washer, Flat .531x1.062x.095
28	12594	1	Washer, Oil Drain
29	120384	11	Washer, Lock 1/2 SP
30	22495	2	Housing, Axle
31	12597	AR	Gasket, Axle Housing
32	131017	2	Washer, Flat .812x1.469x.134
33	426913	2	Screw, Set 7/16-14x1.00
34	22554	1	Assembly, Diff. Std. 6 Lead
35	22561	2	Assembly, Differential Housing

SWIFTAMATIC DIFFERENTIAL, MODELS 5240, 5260, 5645 AND 5665

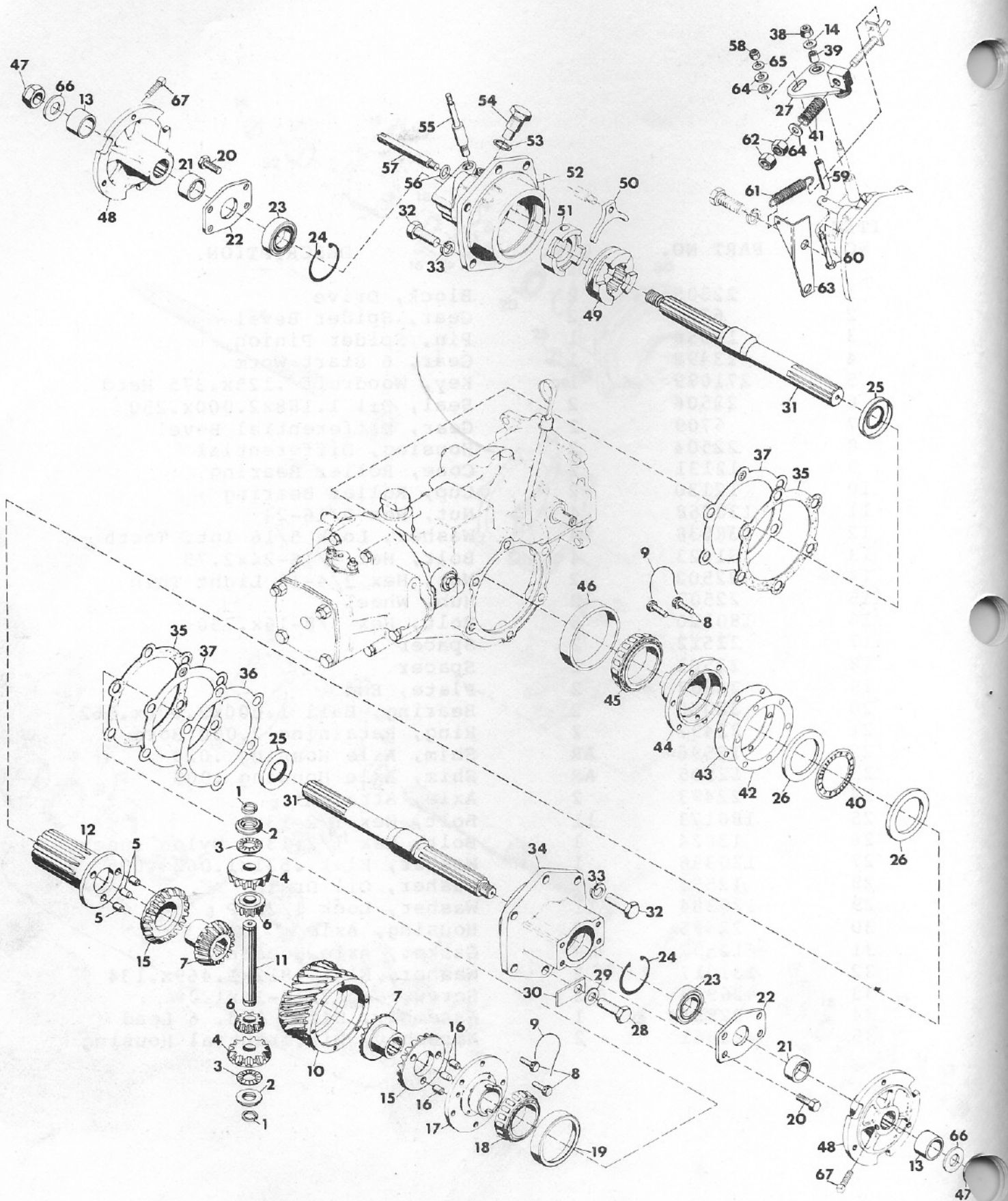

SWIFTAMATIC DIFFERENTIAL, MODELS 5240, 5260, 5645 AND 5665

ITEM NO.	PART NO.	QTY.	DESCRIPTION
1	15733	2	Ring, Retaining .750 Shaft
2	15734	2	Spacer .765x1.245x.200
3	6741	2	Bearing, Needle Thrust .752x1.240x.078
4	6702	2	Gear, Differential Shifting Bevel
5	34644	3	Pin, Dowel .375x.375
6	6708	2	Gear, Spider Bevel
7	6709	2	Gear, Differential Bevel
8	18604	12	Bolt, Special 5/16-18
9		2	Wire, Bolt
10	15729	1	Gear, Worm 8 Start
11	22499	1	Pin, Spider
12	22498	1	Shifter, Splined Pinned
13	22512	2	Spacer
14	120393	1	Washer, Flat .344x.688x.065
15	6703	2	Gear, Pinned Bevel
16	6714	3	Pin, Dowel .375x.500
17	12126	1	Housing, Pinned
18	12131	1	Cone, Roller Bearing
19	12130	1	Cup, Roller Bearing
20	180120	8	Bolt, Hex 3/8-16x.750
21	22501	2	Spacer
22	22503	2	Plate, End
23	32050	2	Bearing, Ball 1.000x2.000x.562
24	22497	2	Ring, Retaining 2.000 Bore
25	22506	2	Seal, Oil 1.188x2.000x.250
26	22500	2	Race, Thrust 2.002x2.740x.031
27	6723	1	Arm, Shifter
28	13624	1	Bolt, Hex 1/2-13x1 Nylon Insert
29	120396	1	Washer, Flat .531x1.062x.095
30	12594	1	Washer, Oil Drain
31	22493	2	Axle, Straight
32	180173	11	Bolt, Hex 1/2-13x1
33	120384	11	Washer, Lock 1/2 SP
34	22495	1	Housing, Axle
35	12597	AR	Gasket, Axle Housing
36	12595	AR	Shim, Axle Housing .005
37	12596	AR	Shim, Axle Housing .020
38	419455	1	Nut, Lock 5/16-18
39	6724	1	Bushing, Nylon .375x.503x.875
40	6743	1	Race, Bearing Thrust .060
41	10682	1	Spring, Compression 2x.720
42	6739	3	Shim, Clutch Worm Gear .005
43	6740	1	Shim, Clutch Worm Gear .020
44	22496	1	Housing, Clutch
45	12501	1	Cone, Roller Bearing
46	12500	1	Cup, Roller Bearing
47	22502	2	Nut, Hex 3/4-10 Light Thin
48	22507	2	Hub, Wheel
49	11632	1	Clutch, Shifting
50	6719	1	Yoke, Shifting

SWIFTAMATIC DIFFERENTIAL, MODELS 5240, 5260, 5645 AND 5665

ITEM NO.	PART NO.	QTY.	DESCRIPTION
51	11156	1	Clutch, Stationary
52	22494	1	Housing, Axle 2-Speed
53	12707	1	Washer, Oil Strainer Nut
54	6734	1	Bolt, Stationary Clutch
55	10505	1	Pivot, Stationary
56	6732	1	O-Ring .438x.625x.094
57	6721	1	Pin, Clutch Sliding
58	419454	1	Nut, Lock 1/4-20
59	24382	1	Bushing
60	24383	1	Bolt
61	10681	1	Spring, Extension 2.50x.62
62	124925	2	Nut, Jam 3/8-24 Hex
63	10680	1	Bracket, Spring 2-Speed
64	120394	3	Washer, Flat .406x.812x.065
65	120392	1	Washer, Flat .281x.625x.065
66	131017	2	Washer, Flat .812x1.469x.134
67	426913	2	Screw, Set 7/16-14x1.00

WHEELS

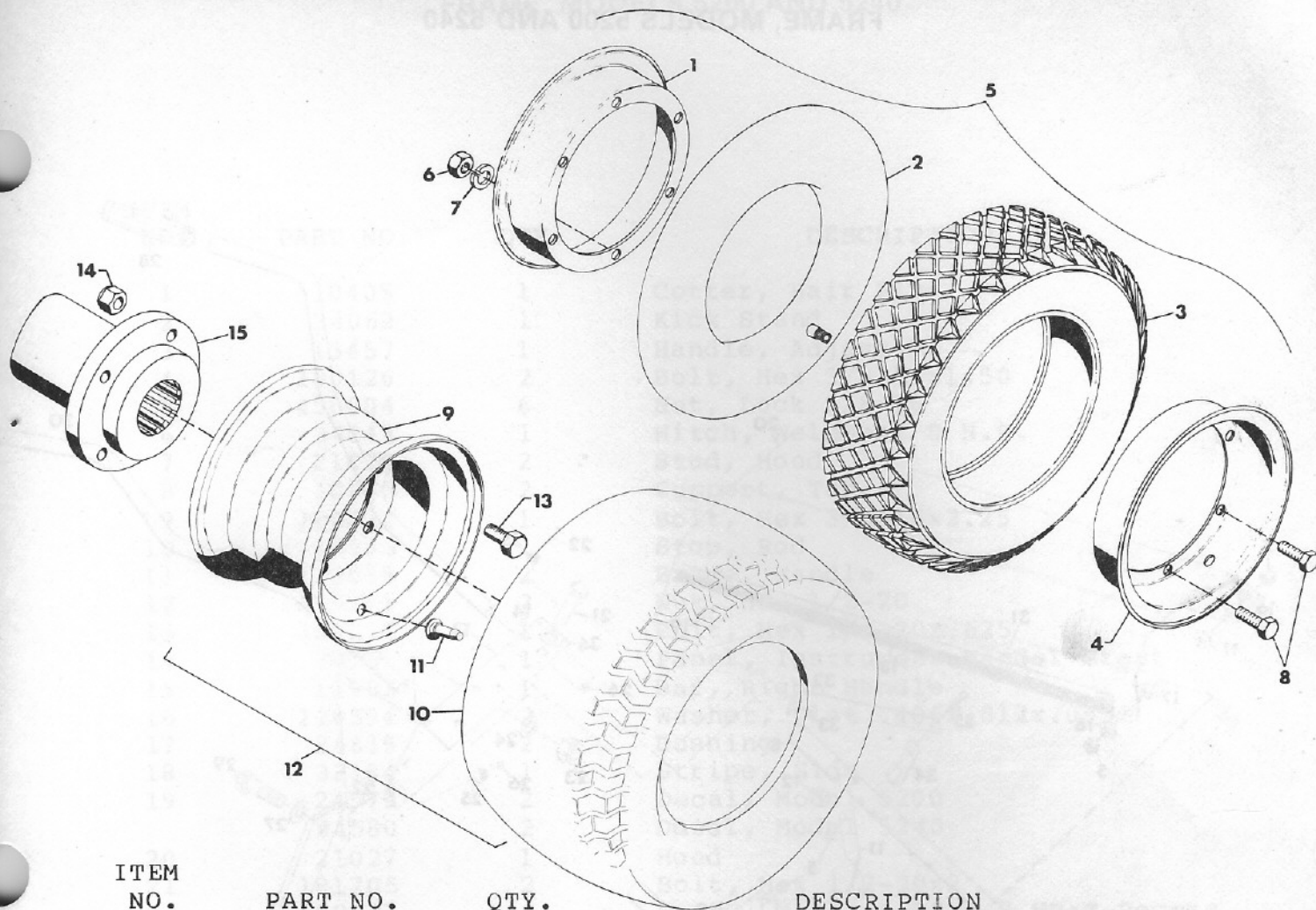

ITEM NO.	PART NO.	QTY.	DESCRIPTION
1	12674	1	Disc, Inner Wheel
2	11645	1	Tube
3	13836	1	Tire, Tractor Diamond Tread 4.80x4.00-8
	13835	1	Tire, Tractor Ground Grip 4.00-8
	18762	1	Tire, Semi-Pneumatic 16x5Wx3
	19562	1	Tire, 18x6.50-8
4	12673	1	Disc, Wheel
5	10141	1	Assembly, Super Grip Wheel 4.00-8
	10142	1	Assembly, Diamond Tread Wheel 4.80x4.00-8
	19563	1	Tire, Wheel Assembly 18x6.50-8
	21221	1	Wheel, Semi-Pneumatic Assembly 16x5Wx3
6	124829	3	Nut, Jam 3/8-16 Hex
7	120382	3	Washer, Lock 3/8 SP
8	428638	3	Bolt, Hex 3/8-16x.625
	180120	3	Bolt, Hex 3/8-16x.750
9	23267	1	Rim, 18x8.50-8
10	15222	1	Tire 18x8.50-8
11	11191	1	Assembly, Valve Stem
12	23268	1	Assembly, Wheel 18x8.50x8
13	180177	4	Bolt, Hex 1/2-13x1.50
14	435507	4	Nut, Lock 1/2-13
15	22551	1	Hub, for 18x8.50x8 Wheel Assembly

FRAME, MODELS 5200 AND 5240

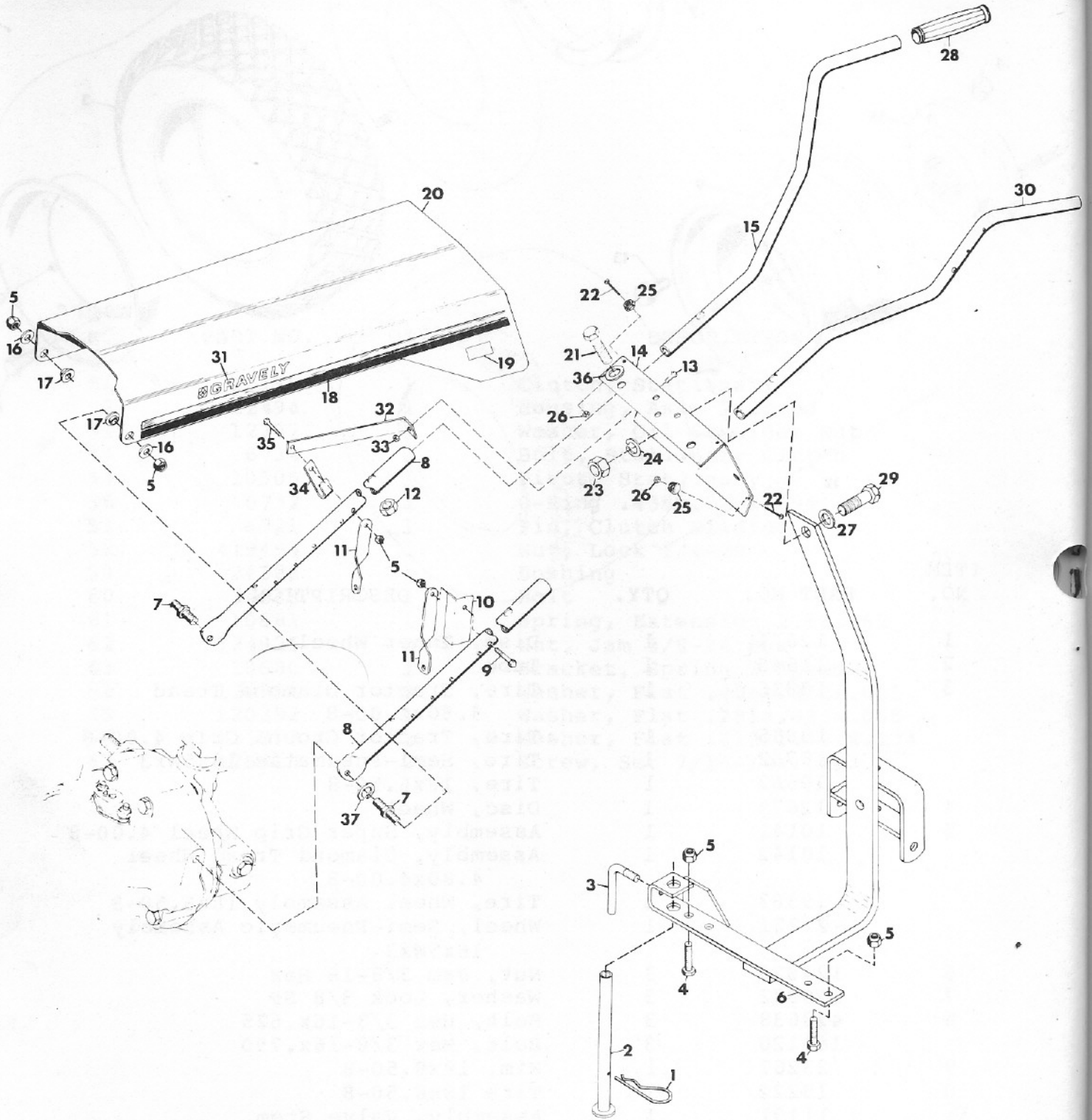

FRAME, MODELS 5200 AND 5240

ITEM NO.	PART NO.	QTY.	DESCRIPTION
1	10405	1	Cotter, Hair Pin
2	34062	1	Kick Stand
3	13457	1	Handle, Adjusting
4	180126	2	Bolt, Hex 3/8-16x1.50
5	456004	6	Nut, Lock 3/8-16
6	24844	1	Hitch, Weldment 8 H.P.
7	21028	2	Stud, Hood
8	10643	2	Support, Tube
9	180132	1	Bolt, Hex 3/8-16x2.25
10	10933	1	Stop, Rod
11	10655	2	Brace, Handle
12	120371	2	Nut, Hex 1/2-20
13	180018	1	Bolt, Hex 1/4-20x.625
14	24751	1	Panel, Instrument Manual Start
15	11982	1	Bar, Right Handle
16	120394	2	Washer, Flat .406x.812x.065
17	24815	2	Bushing
18	32184	1	Stripe, Side
19	24579	2	Decal, Model 5200
	24580	2	Decal, Model 5240
20	21027	1	Hood
21	181705	2	Bolt, Hex 1/2-20x2
22	159341	4	Screw, Mach. 6-32x5/8 HD C-Recess
23	124589	1	Nut, Hex 5/8-11
24	121574	1	Washer, Lock 5/8 SP
25	18183	4	Bumper
26	427254	4	Nut, Mach. Lock 6-32
27	421879	1	Washer, Flat .656x1.250x.100
28	10671	2	Grip, Hand
29	271547	1	Bolt, Hex 5/8-11x1.50
30	10658	1	Bar, Left Handle
31	24588	2	Decal, Gravely Logo
32	10996	1	Brace, Instrument Panel
33	419454	1	Nut, Lock 1/4-20
34	10684	1	Retainer, 2-Speed Control
35	180134	1	Bolt, Hex 3/8-16x2.50
36	120396	2	Washer, Flat .531x1.062x.095
37	120382	2	Washer, Lock 3/8 Reg.
NS	38056	1	Decal, America

NOTE: Item Numbers 13, 32, 33, and 34 pertain only to Tractor Model 5240.

FRAME, MODELS 5260, 5645 AND 5665

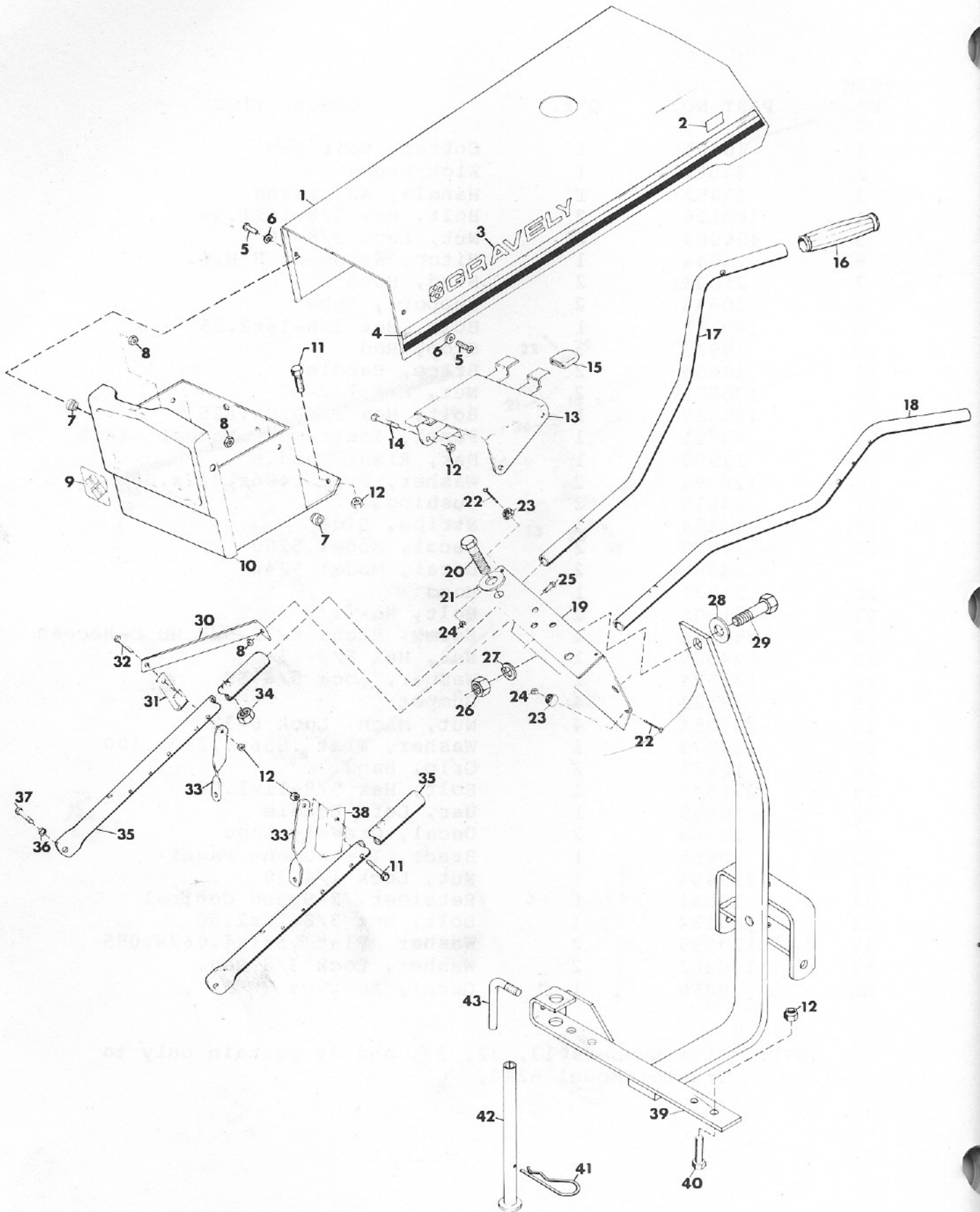

FRAME, MODELS 5260, 5645 AND 5665

ITEM NO.	PART NO.	QTY.	DESCRIPTION
1	10650	1	Hood
2	34141	2	Decal, Model 5665
	24583	2	Decal, Model 5260
	34140	2	Decal, Model 5645
3	24588	2	Decal, Gravely Logo
4	31831	1	Decal, Side Stripes
5	160556	2	Screw, Mach. 1/4-20x1 Pan HD
6	120392	2	Washer, Flat .281x.625x.065
7	12117	2	Pivot, Hood
8	419454	3	Nut, Lock 1/4-20
9	10697	1	Decal
10	10644	1	Weldment, Grille
11	180132	3	Bolt, Hex 3/8-16x2.25
12	456004	8	Nut, Lock 3/8-16
13	10637	1	Weldment, Fuel Tank Bracket
14	180129	4	Bolt, Hex 3/8-16x1.875
15	31620	4	Cover 1.0x.125x1.0
16	10671	2	Grip, Hand
17	11982	1	Bar, Right Handle
18	10658	1	Bar, Left Handle
19	24744	1	Instrument Panel Model 5260
	24751	1	Instrument Panel Model 5645
	37758	1	Instrument Panel Model 5665
20	181705	2	Bolt, Hex 1/2-20x2
21	120396	2	Washer, Flat .531x1.062x.095
22	159341	4	Screw, Mach. 6-32x5/8 Pan HD CR
23	18183	4	Bumper
24	427254	4	Nut, Mach. Lock 6-32
25	180018	1	Bolt, Hex 1/4-20x.625
26	124589	1	Nut, Hex 5/8-11
27	121574	1	Washer, Lock 5/8 SP
28	421879	1	Washer, Flat .656x1.250x.100
29	271547	1	Bolt, Hex 5/8-11x1.50
30	10996	1	Brace, Instrument Panel
31	10684	1	Retainer, 2-Speed Control
32	180134	1	Bolt, Hex 3/8-16x2.50
33	10655	2	Brace, Handle
34	120371	2	Nut, Hex 1/2-20
35	10643	2	Support, Tube
36	120382	2	Washer, Lock 3/8 SP
37	180122	2	Bolt, Hex 3/8-16x1
38	10933	1	Stop, Rod
39	24844	1	Hitch, Weldment 8 H.P.
	24843	1	Hitch, Weldment 12 H.P.
40	180126	2	Bolt, Hex 3/8-16x1.50
41	10405	1	Cotter, Hair Pin
42	34062	1	Kick Stand
43	13457	1	Handle, Adjusting
NS	38056	1	Decal, America

CONTROLS

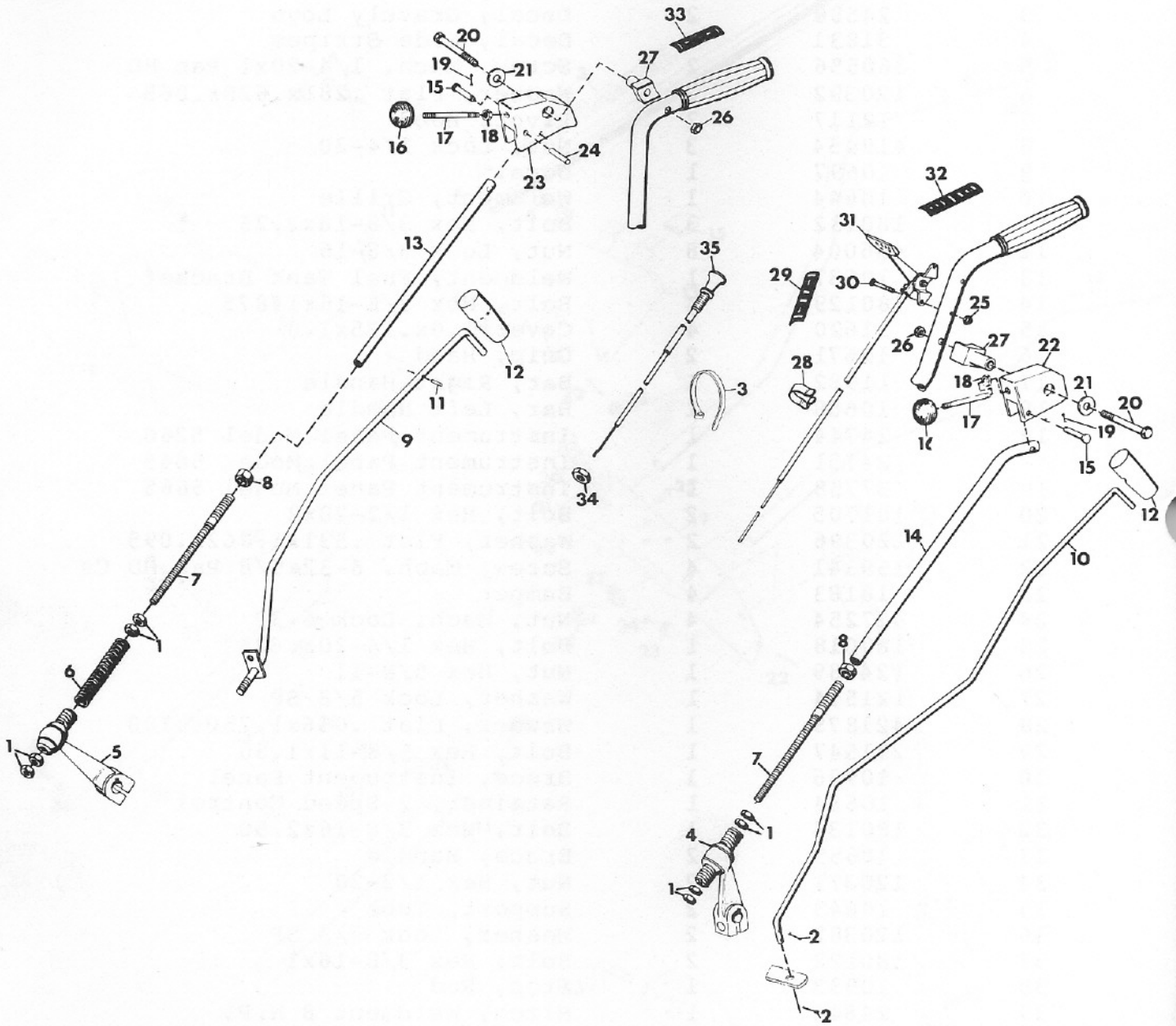

CONTROLS

ITEM NO.	PART NO.	QTY.	DESCRIPTION
1	124829	8	Jam, Hex 3/8-16
2	121224	2	Pin, Cotter .094x1.000
3	10629	1	Tie, Cable
4	21383	1	Assembly, Hi-Lo Lever
5	21384	1	Assembly, Fwd-Rev Lever
6	21506	1	Spring, Fwd-Rev Neutral Return
7	20269	2	Rod, Control Extension
8	120238	2	Nut, Jam 1/2-13
9	10677	1	Rod, 2-Speed Control
10	10932	1	Rod, Attachment
11	423664	1	Pin, Spring .094x.688
12	10683	1 (5200) 2 (5240, 5260, 5665, 5645)	Handle, Rubber Shifter
13	20267	1	Rod, Fwd-Rev Control
14	20268	1	Rod, Hi-Lo Control
15	10672	2	Pin, Clevis .375x1.250
16	10670	2	Knob, Control
17	10669	2	Rod, Shifter
18	272123	2	Nut, Jam 7/16-20 Hex
19	177923	2	Pin, Cotter .125x.750
20	180192	2	Bolt, Hex 1/2-13x3.50
21	120396	2	Washer, Flat .531x1.062x.095
22	10666	1	Support, Hi-Lo Shifter Rod
23	11985	1	Support, Fwd-Rev Shifter Rod
24	453670	1	Pin, Spring .25x.125
25	190254	2	Nut, Lock 10-24
26	20541	2	Nut
27	10667	2	Pivot, Handle Lever
28	8260	1	Clip, Conduit
29	21091	1	Decal, Gear Shift
30	436738	2	Screw, Mach 10-24x1.50 Pan HD
31	21103	1	Lever, Throttle Control 8 H.P.
	21196	1	Lever, Throttle Control 12 H.P.
32	21092	1	Decal, Throttle
33	21090	1	Decal, Fwd-Rev
34	124925	1	Nut, Jam 3/8-24 Hex
35	10696	1	Control, Choke

NOTE: Item Numbers 9 and 11 pertain to Tractor Models 5240, 5260, 5665 and 5645.
Item Numbers 34 and 35 pertain to Tractor Models 5260 and 5665.

FUEL SYSTEM AND EXHAUST

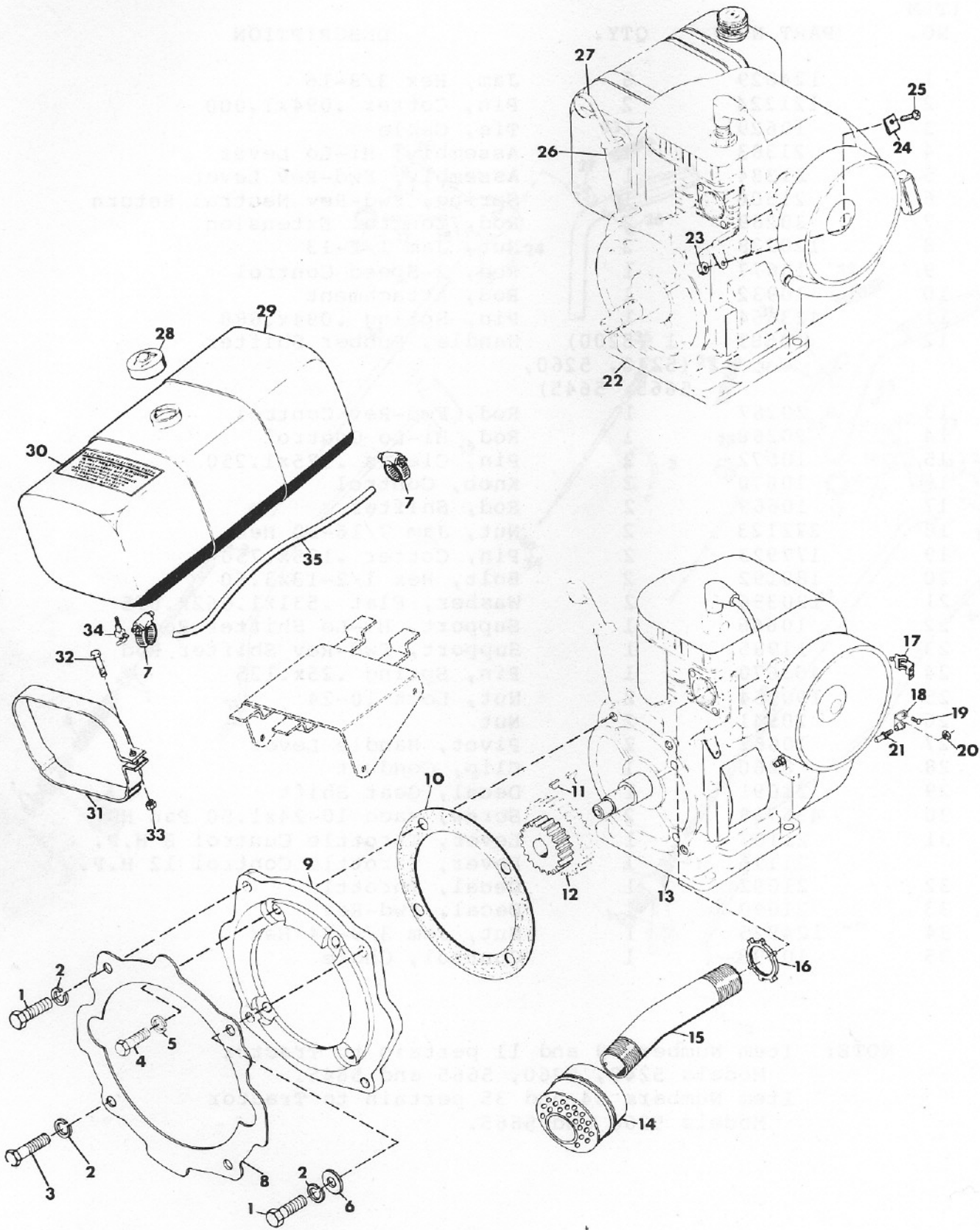

FUEL SYSTEM AND EXHAUST

ITEM NO.	PART NO.	QTY.	DESCRIPTION
1	180149	2	Bolt, Hex 7/16-14x1.50
2	131100	4	Washer, Lock 7/16 SP Heavy
3	180147	2	Bolt, Hex 7/16-14x1.25, 8 H.P.
	180146	2	Bolt, Hex 7/16-14x1.125, 12 H.P.
4	180121	4	Bolt, Hex 3/8-16x.875, 8 H.P.
	180122	4	Bolt, Hex 3/8-16x1, 12 H.P.
5	131099	4	Washer, Lock 3/8 SP Heavy
6	120395	1	Washer, Flat .469x.938x.065
7	32045	2	Clamp, Hose
8	10635	1	Gasket, Chassis to Adaptor
9	14938	1	Adaptor, Engine 8 H.P.
	10731	1	Adaptor, Engine 12 H.P.
10	10732	1	Gasket, Engine to Adaptor 12 H.P.
	15718	1	Gasket, Engine to Adaptor 8 H.P.
11	124546	2	Key, Woodruff 5/32x5/8 Hard
12	17838	1	Gear, 10/12 DP 21/30 Teeth
13	38264	1	Engine, 12 H.P. 2-Wheel Electric
	38266	1	Engine, 12 H.P. 2-Wheel Manual
14	8227	1	Muffler, 12 H.P.
15	10865	1	Tube, Muffler 12 H.P.
16	10866	1	Nut, Conduit 1 Pipe
17	7331	1	Clip, Speed
18	18522	1	Bracket
19	160515	1	Screw, Mach. 1/4-20x.50 Pan HD
20	120375	1	Nut, Hex 1/4-20
21	18521	1	Adaptor, Conduit
22	21042	1	Engine, 8 H.P. 2-Wheel Manual
	24639	1	Engine, 8 H.P. 2-Wheel Electric
23	190254	1	Nut, Lock 10-24
24	15453	1	Clip
25	159920	1	Screw, Mach. 10-24x.50 Pan HD
26	21174	1	Tube, Oil Fill
27	21173	1	Dipstick
28	10756	1	Cap, Gas Tank
29	10636	1	Assembly, Fuel Tank
30	11989	1	Decal, E. S. Warning Models 5260 and 5665
31	10640	2	Strap, Fuel Tank
32	180024	2	Bolt, Hex 1/4-20x1.25
33	419454	2	Nut, Lock 1/4-20
34	7354	1	Valve and Strainer
35	21134	2 ft.	Line, Fuel

NOTE: Item Numbers 13 through 21 pertain to 12 H.P. Engine Models. Item Numbers 22 through 25 pertain to 8 H.P. Engine Models. Item Numbers 26 and 27 pertain to Model 5260. Item Numbers 7 and 28 through 35 pertain to Models 5260, 5665, and 5645.

ELECTRICAL

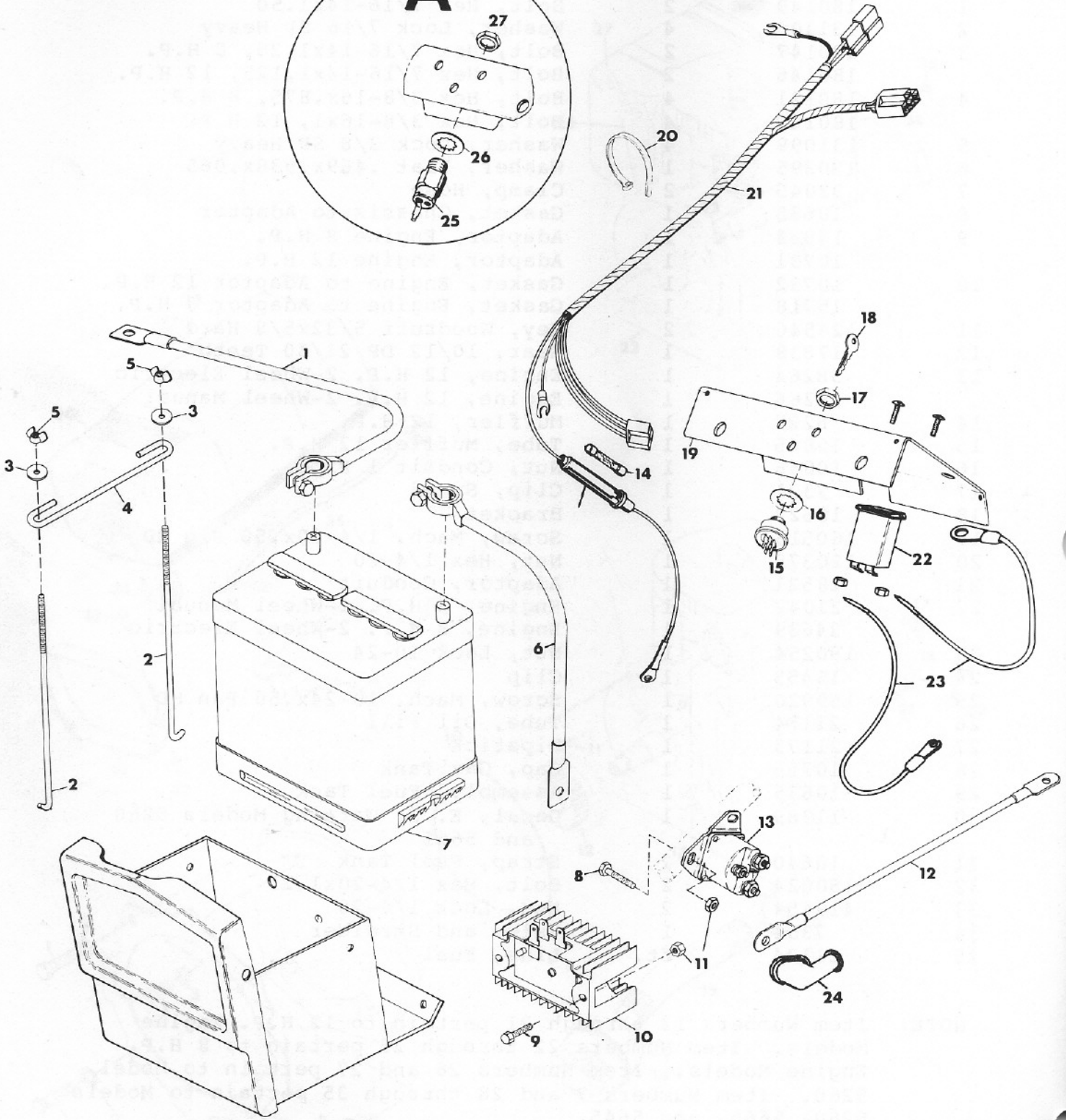
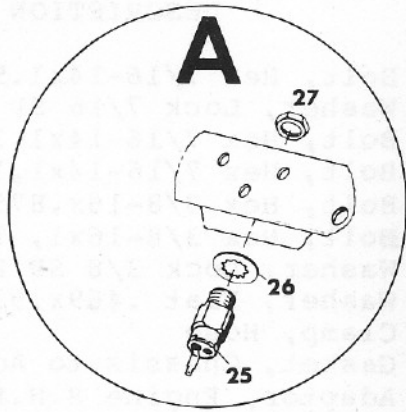

ELECTRICAL

ITEM NO.	PART NO.	QTY.	DESCRIPTION
1	21368	1	Cable, Positive Battery
2	12894	2	Bolt, Hold-Down
3	446354	2	Washer, Flat .313x.875x.065
4	37743	1	Hold-Down, Battery
5	10413	2	Nut, Wing 1/4-20
6	6980	1	Cable, Negative Battery
7	37764	1	Battery, 12 Volt Maintenance-Free
8	180042	2	Bolt, Hex 1/4-20x1.75
9	180020	2	Bolt, Hex 1/4-20x.75
10	18009	1	Regulator, Rectifier
11	120375	2 (5260) 4 (5665)	Nut, Hex 1/4-20
12	6981	1	Cable, Magnetic Switch to Starter
13	7277	1	Switch, Magnetic
14	14893	1	Fuse, 30 AMP Acc-30
15	19223	1	Switch, Ignition
16	19667	1	Washer, Lock (5260, 5665)
17	19666	1	Nut, Jam 9/16-24 (5260, 5665)
18	18570	1	Key, Ignition Switch
19	24751	1	Panel, Instrument (5200, 5240, 5645)
	24744	1	Panel, Instrument (5260)
	37758	1	Panel, Instrument (5665)
20	10629	5	Tie, Cable
21	24759	1	Harness, Wiring 3 AMP (5260)
	19222	1	Harness, Wiring 15 AMP (5665)
22	38256	1	Hourmeter
23	21425	2	Wire, Instrument Panel
24	33847	3	Boot, Battery Cable (5260, 5665)
25	21104	1	Switch, Ignition
26	18586	1	Washer, Lock (5200, 5240, 5645)
27	18585	1	Nut, Jam 5/8-32 (5200, 5240, 5645)

NOTE: Item Numbers 9, 10, 22, and 23 pertain to Tractor Model 5665 only.
Circle "A" pertains to Manual Start models only.