



# 40" WING MOWER OPERATOR'S MANUAL

## SECTION 1

### INSTRUCTIONS FOR SAFE OPERATION

Improper use of this equipment can injure people and damage the equipment. People using or servicing this equipment must read and follow the instructions in this manual.

It is important to understand that this manual and any other Gravely manuals that may be used cover every possible danger. It is impossible for Gravely to know all the dangers in operating and servicing the equipment.

The purchaser must give these instructions to all persons operating and servicing the equipment. These people must use common sense.

### NOTE

Read this manual carefully and learn to operate and service your 40" Wing Mower before using it.

To keep the warranty, the 40" Wing Mower must be maintained and operated as directed in this manual.

All references to "left-side", "right-side", "front", and "back" are given from the operator's position.

SERIAL NUMBER \_\_\_\_\_



Look for this symbol to point out important safety precautions. It means — ATTENTION! BECOME ALERT! YOUR SAFETY IS INVOLVED.

10. Replace all parts that become damaged or lost.

#### 1.2 Operation:

1. Wear hand, foot, head, ear and eye protection. Do not wear loose clothing.
2. Do not use the equipment in the dark without adequate lighting.
3. Keep the equipment in good condition. Maintain it as directed in this manual.

## CONTENTS

1. INSTRUCTIONS FOR SAFE OPERATION
2. OPERATING INSTRUCTIONS
3. SERVICE INSTRUCTIONS
4. STORAGE
5. SOLVING PROBLEMS
6. ILLUSTRATED PARTS AND PARTS LIST
7. SPECIFICATIONS AND WIRING
8. SET-UP INSTRUCTIONS
9. WARRANTY

Look for this symbol to point out important safety precautions.  
It means — ATTENTION! BECOME ALERT! YOUR SAFETY  
IS INVOLVED.



## SECTION 1

### INSTRUCTIONS FOR SAFE OPERATION

Improper use of this equipment can injure people and damage the equipment. People using or servicing this equipment must read and follow the instructions in this manual.

It is important to understand that this manual and any other Gravely instruction manuals do not cover every possible danger. It is impossible for Gravely to know all possible dangers in operating and servicing the equipment.

The purchaser must give these instructions to the people operating and maintaining this equipment. These people must use eye and foot protection.

#### **1.1 Preparation:**

1. Read this manual and the tractor manual carefully.
2. Learn the location and function of all controls.
3. Learn how to use the controls to stop the wheels and mower quickly.
4. Use caution with gasoline. Gasoline is very flammable. Keep it in a clean and tight container away from flames or hot items. Never put gasoline in the fuel tank while the engine is running or hot. Clean up spilled gasoline before starting engine.
5. Be certain that all shields, guards, and interlock switches are in the correct positions.
6. Never permit children to operate the tractor and mower.
7. Inspect area to be mowed and remove all material which could be thrown by the mower.
8. Before starting the wing mower engine, put the PTO control lever in the "OFF" position, the gear shift lever in the neutral "N" position and start the tractor engine.
9. When hauling the equipment, connect the chassis to the transporting vehicle. Never connect from control levers, rods, or like items that could be damaged.
10. Replace all parts that become damaged or lost.

#### **1.2 Operation:**

1. Wear hand, foot, head, ear and eye protection. Do not wear loose clothing.
2. Do not use the equipment in the dark without adequate lighting.
3. Keep the equipment in good condition. Maintain it as directed in this manual.



4. **USE ONLY GRAVELLY ACCESSORIES AND ATTACHMENTS.**
5. **Do not overspeed the engine. Do not override the governor.**
6. **Keep away from moving parts.**
7. **Keep people and animals away from the operating area.**
8. **Do not let people other than the operator near the operating equipment.**
9. **Use a slow speed and engage the direction control slowly when operating on slopes.**
10. **Look for and keep away from hazards.**
11. **After hitting an object, stop the equipment and engine. Check for damage. Repair any damage before operating.**
12. **Look behind when operating in reverse. Look for people and hazards.**
13. **Operate only from the operator's position.**
14. **Travel up and down slopes.**
15. **If there is a sudden change in the sound or vibration of the equipment, stop the engine and check for damage. Repair any damage or failure before continuing operation.**
16. **Never run the engine indoors except to move it outside. Exhaust fumes are dangerous.**
17. **Go slowly on slick surfaces.**
18. **Follow traffic laws when operating on or near a road.**
19. **Before making adjustments or servicing, move the throttle control (on the wing mower) to the "SLOW" position and turn the ignition switch (on the wing mower) to the "OFF" position. Move the PTO to "OFF", turn the ignition switch to "OFF" and wait until all moving parts completely stop.**
20. **Before leaving the operator's position, move the throttle control (on the wing mower) to the "SLOW" position and turn the ignition switch (on the wing mower) to the "OFF" position. Put the PTO control in the "OFF" position, lock the brake or put in gear and engage the direction control pedal, and remove the ignition key. Wait until all moving parts completely stop.**

## SECTION 2

### OPERATING INSTRUCTIONS

- 2.1 Transport the equipment to the area to be mowed.
- 2.2 Inspect the area to be mowed and remove all material which could be thrown by the mower.
- 2.3 Plan the pattern for cutting the grass. Generally an area is mowed around the periphery towards the center by discharging the grass toward the center on the first pass. The remainder of the mowing is done discharging the grass outward in the area which has been cut.
- 2.4 Start the wing mower as follows:
  1. Start the tractor engine. Move the wing mower throttle control to the "CHOKE" position if the engine is cold.
  2. Turn the wing mower ignition switch to the "START" position.

**NOTE:** The wing mower engine starter will engage anytime the ignition switch is turned to the "START" position, but the wing mower engine will not run unless the tractor engine is running.

3. When the engine starts and is running, move the throttle control to the "SLOW" position.

 **WARNING:** Use a slow tractor speed the first time you use the wing mower.

- 2.5 Lower the mower on the tractor to the ground.
- 2.6 Put the range selector in the "HI" position.
- 2.7 Put the gear selector in the "2" position.
- 2.8 See the tractor manual for correct operation of the PTO. Put the PTO control in the "ON" position to engage the mower on the tractor.
- 2.9 Move the throttle lever on the tractor to the "FAST" position.
- 2.10 Move the throttle lever on the wing mower to the "FAST" position. Always operate the wing mower with the throttle lever in the "FAST" position.
- 2.11 Put the direction control in the forward position. Mow a distance of ten feet (3 meters). Stop the tractor, move the throttle lever (on the wing mower) to the "SLOW" position and remove the wing mower ignition key. Put the PTO control in the "OFF" position and remove the ignition key.

 **WARNING:** Wait until both engines and mowers have completely stopped.

- 2.12 Check to see if both the mowers are cutting the grass to the height that is needed.
- 2.13 If the wing mower cutting height needs to be adjusted, follow the instructions in Section 3 of this manual. If the other tractor's mower cutting height needs to be adjusted, follow the instructions in the operator's manual for that mower.
- 2.14 Use the edge locator on the wing mower deck to see the location of the edge of the mower deck when trimming around an object. See Figure 1.
- 2.15 After you know how to operate the tractor with the wing mower, select the speed of the tractor which is best for your mowing conditions. Control the ground speed by selecting the desired gear.

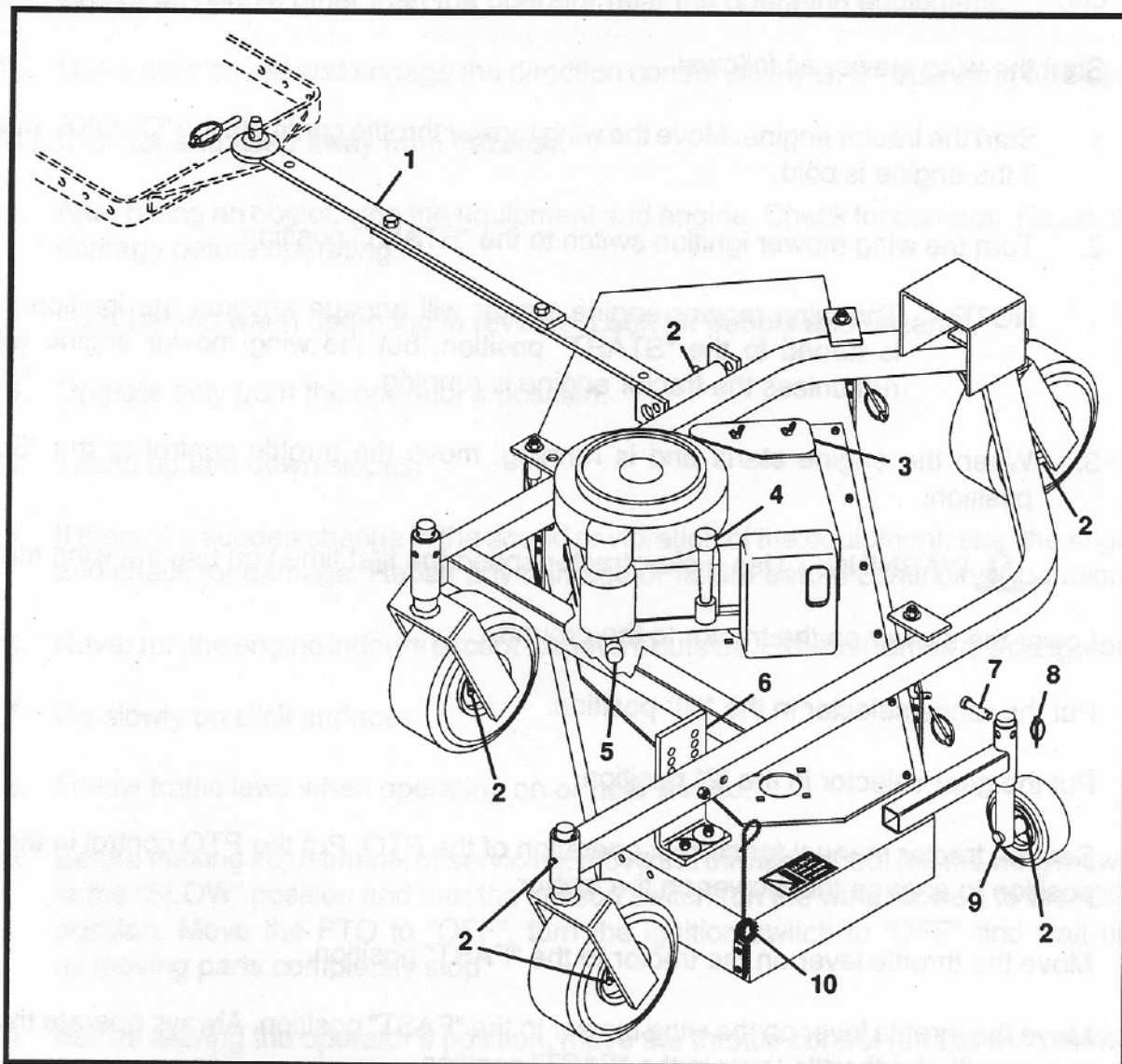

- |                   |                               |
|-------------------|-------------------------------|
| 1 - Drawbar       | 6 - Height Adjustment Bracket |
| 2 - Lube Fitting  | 7 - Clevis Pin                |
| 3 - Air Cleaner   | 8 - Klik Pin                  |
| 4 - Oil Fill Tube | 9 - Caster Wheel Weldment     |
| 5 - Oil Drain     | 10 - Edge Locator             |

FIGURE 1



## SECTION 3

### SERVICE INSTRUCTIONS

Chart 1 shows the recommended schedule for service that should be performed on a regular basis.

MAINTENANCE SCHEDULE					
SERVICE PERFORMED	TIME INTERVALS BETWEEN SERVICE				
	DAILY	25 HR.	50 HR.	100 HR.	500 HR.
General Lubrication (Section 3.1)		X			
Check the Engine Oil (Section 3.2)	X				
Check the Fasteners (Section 3.4)	X				
Check the Battery (Section 3.5)				X	
Check the Cooling System (Section 3.6)		X			
Check Air Cleaner (Section 3.7)	X				
Check Tire Pressure (Section 7)		X			

CHART 1

#### 3.1 General Lubrication

There are twelve grease fittings to be greased at 25-hour intervals. Clean the fittings before attaching the grease gun. Use a multi-purpose grease. Add grease until it appears at the ends of the bearings. The locations of the twelve fittings are:

1. One on each spindle assembly. See Figure 2.
2. One on each idler weldment. See Figure 2.
3. Two on the frame weldment. See Figures 1 and 3.
4. One on each gauge wheel. See Figures 1 and 3.
5. One on the drawbar. See Figure 1.

#### 3.2 Checking the Engine Oil

Check the engine oil level daily. Never operate the engine with the oil level below the low mark on the dipstick. See your engine manual for oil specifications and oil filter service instructions. To check the oil level:

1. Clean around the dipstick to prevent dirt from entering the tube. See Figure 1.
2. Remove the dipstick and wipe off the oil.



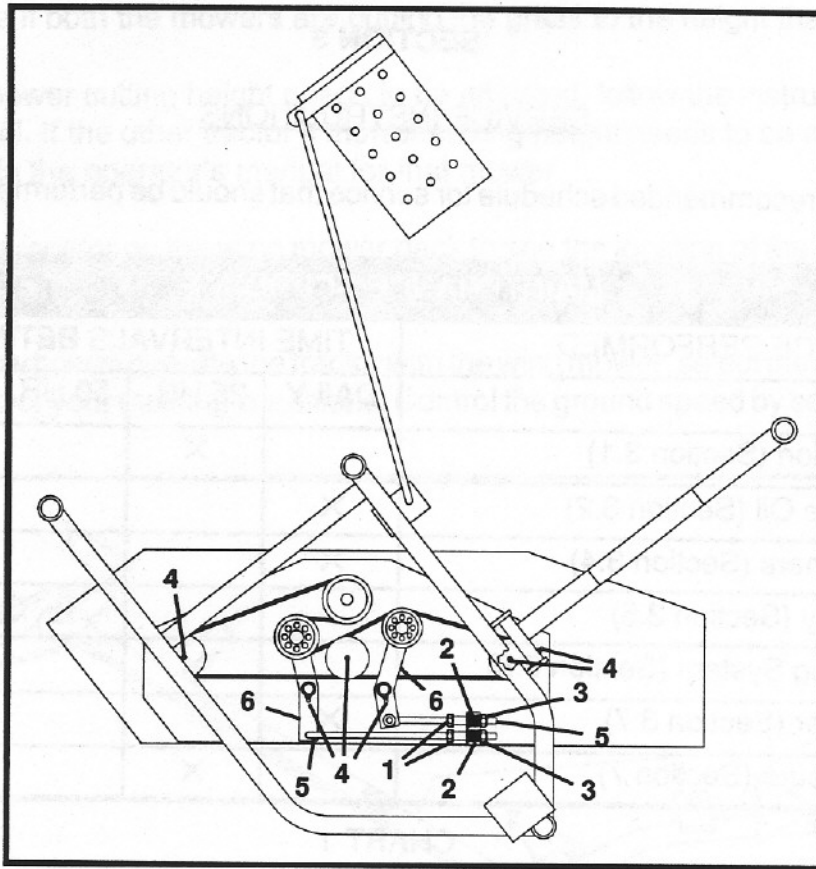

- 1 - Adjusting Nut
- 2 - Spring
- 3 - Locking Nut
- 4 - Lube Fitting
- 5 - Idler Rod
- 6 - Idler Weldment

FIGURE 2

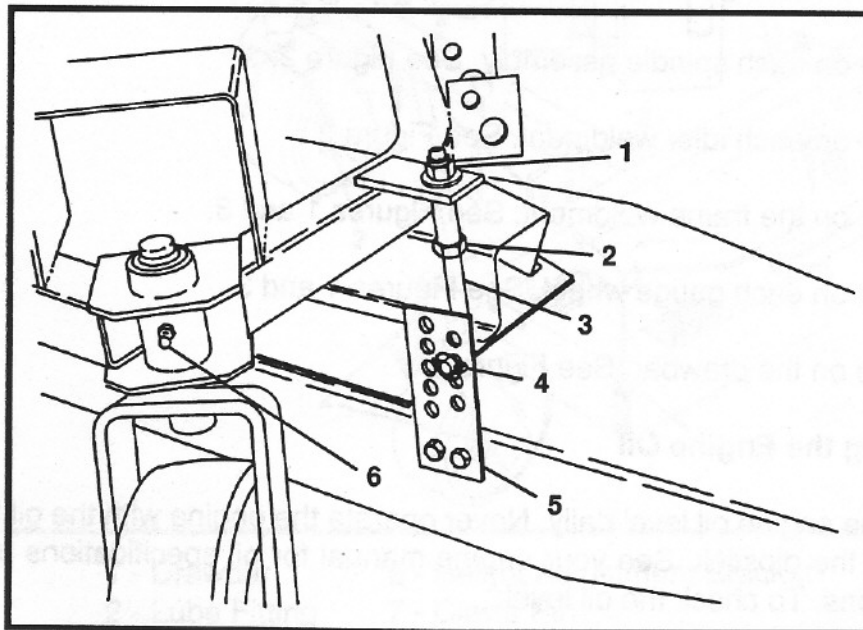

- 1 - Lock Nut
- 2 - Jam Nut
- 3 - Height Adjustment Rod
- 4 - Klik Pin
- 5 - Adjustment Bracket
- 6 - Lube Fitting

FIGURE 3

3. Put the dipstick back in place. Be sure it is all the way down.
4. Remove the dipstick again and note oil level.
5. Add oil, if needed. Do not overfill.
6. Repeat Step 3.

### 3.3 Changing the Engine Oil

1. Read your engine manual for recommended change schedule.
2. Move the tractor to a level area. Lock the brake.
3. If the engine is cold, let it run for 5 minutes.
4. When the engine is warm, stop it.

 **WARNING:** Engine muffler and other parts are hot.

5. Clean the areas around the dipstick and drain plug. See Figure 1.
6. Remove the dipstick.
7. Put an open top container that will hold four quarts under the drain plug.
8. Remove the drain plug.
9. Allow the engine to drain completely.
10. Clean and reinstall the drain plug.
11. Remove the oil filter (some models), clean the oil filter port and install a new oil filter according to the instructions on the oil filter.
12. Fill with new oil to the "FULL" mark on the dipstick.
13. Replace the dipstick.
14. Start the engine and check for leakage at the drain plug. Tighten the plug if leakage occurs.

### 3.4 Checking the Fasteners

Check all fasteners periodically. Look for loose or missing fasteners any time looseness of parts, rattles, or excess noise and vibration are noted. Make sure all bolts, screws, nuts, pins, snap rings, and cotter pins are in the correct position and replace any that are missing. See Chart 2.

BOLT TORQUE SPECIFICATIONS		
BOLT SIZE	FOOT POUNDS (ft.lbs.)	NEWTON METERS (N.m)
1/4"(6mm)	7	9.5
5/16"(8mm)	14	19
3/8"(10mm)	25	34
7/16"	40	54
1/2"(12mm)	60	82
9/16"(14mm)	83	113
5/8"(16mm)	120	163
3/4"	200	217

CHART 2

### 3.5 Checking the Battery

Check the battery fluid every 100 hours. Use caution and wear eye protection when filling the battery. To check the battery:

1. Clean the battery. Look at the two lines around the battery near the top.
2. If the fluid level is below the bottom line, add distilled water. Do not fill above the top line. Do not use a metal funnel.
3. To add distilled water, use a screwdriver to remove and replace each filler cap.

### 3.6 Checking the Air Intake Screen

Check the air intake screen on the engine each day. Remove any grass, dirt, or debris that may have accumulated on it. THE AIR INTAKE SCREEN MUST BE KEPT CLEAN.

### 3.7 Checking the Air Cleaner.

Check the air cleaner each day. See your engine manual for instructions.

### 3.8 Filling the Fuel Tank

 **WARNING:** Gasoline is very flammable. Follow the safety instructions shown in Section 1.

Gasoline is added as required. Use clean lead free or regular grade gasoline. To add gasoline:

1. Put the tractor in an open area.
2. Stop the engine and lock the brake.



3. Clean the fuel cap area.
4. Remove the fuel tank cap.
5. Fill the tank with gasoline. Use caution. Do not overflow.
6. Reinstall fuel tank cap.
7. If gasoline is spilled, wipe it up.

**3.9 Every 25 hours check and adjust the caster wheel air pressure to 20 psi (138 KN/m<sup>2</sup>).**

**3.10 To sharpen the mower blades:**

Every 25 hours of operation inspect the mower blades. Replace any damaged blade.

1. Turn the engine off. Remove the ignition key. Remove the ignition wire from the spark plug.
2. Remove the lock nuts, flat washers and blades from the spindle shafts.
3. Sharpen the beveled edges of the blades. Do not change the angle of the beveled edge. If more than 0.5 inches (12.7 mm) are removed from the width of a blade, discard the blade. Make sure the sharpened blades are balanced.
4. Put the blades, washers and lock nuts back on the spindle shafts. Tighten the lock nuts to a torque of 120 ft.lb. (163 N.m.).
5. Put the ignition wire back on the spark plug.

**3.11 Belt Adjustment**

Check the mower belts after the first 8 hours of operation for proper tension. Thereafter, check the mower belts for proper tension every 25 hours of operation.

1. Stop the engine. Remove the ignition key.
2. Turn the adjusting nuts until there is a gap of .005" to .010" (.127 to .254 mm) between the coils of the springs. See Figure 2.

**3.12 Belt Replacement**

Before each operation, check the belts for cracks or damage. The belts must be replaced if there is damage. To replace the belts, follow the instructions in this section.

1. Stop the engine. Remove the ignition key.
2. Remove the right side and the left side belt covers.



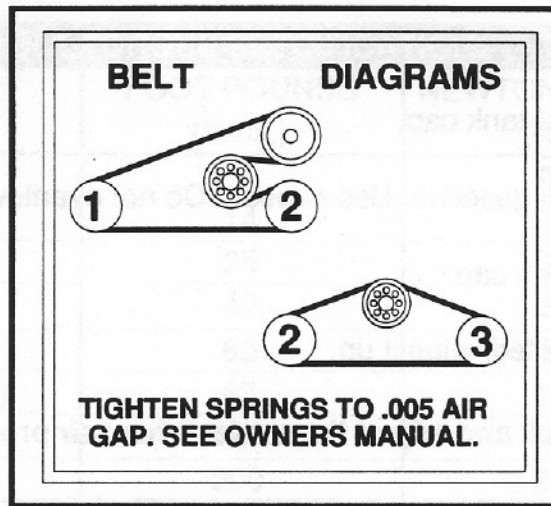

DIAGRAM 1

3. Turn the adjusting nuts on the idler rods counterclockwise until there is no tension on the belts.
4. Remove the old belts.
5. Install new belts as shown in Diagram 1 and on the belt diagram decals on the mower deck.
6. Install the right side and left side belt covers. Adjust the belts as instructed in Section 3.11.

### 3.13 Height of Cut Adjustment:

The cutting height positions are on the mower deck. Each position will raise or lower the cutting height from 1-1/2"(3.81 cm) to 4-1/2"(11.4 cm) in 1/2" (1.27 cm) increments.

To adjust the cutting height of the wing mower, follow the instructions in this section.

1. Remove the nut from the bolt that fastens the height adjustment bracket to the frame. Remove the bolt. See Figure 1.
2. Select the hole in the height adjustment bracket that will give the needed cutting height. Align the hole in the height adjustment bracket with the hole in the frame. Put the bolt through the holes and install the nut. Tighten the bolt to the torque of 60 ft. lbs. (82 N.m).
3. Remove the klik pin from the height adjustment rod.
4. Put the height adjustment rod in the hole in the adjustment bracket that will give the same cutting height position as selected in step 2. Install the klik pin. See Figure 3.
5. Repeat steps 3 and 4 for the other adjustment rods.
6. Adjust the gauge wheel that is on the mower deck to 1/2" (1.27 cm) above the ground.

### 3.14 Wing Mower Leveling Adjustment:

After every 200 hours of operation, check the level of the mower deck. To check or adjust the level of the mower deck, follow the instructions in this section.

1. Put the wing mower on a flat surface.
2. Stop the engine.
3. Make sure all the height adjustments are in the same cutting height position.
4. Measure the distance from the top edge of the mower deck to the floor at the height adjustment bracket. See Figure 3 for the location of the height adjustment bracket.
5. Measure the distance from the top edge of the mower deck to the floor at the height adjustment rods. See Figure 3 for the location of the height adjustment rods.
6. If the distance is not the same, loosen the jam nut that is under the bracket.
7. Turn the lock nut on each height adjustment rod until the measurement from the top edge of the mower deck to the floor is the same as the measurement at the height adjustment bracket. Tighten the jam nut against the sleeve.
8. Repeat steps 4 through 7 until all the measurements are the same.

### 3.15 Installation of the Wing Mower on a Tractor. See Figure 2.

**NOTE:** The 40" wing mower will only fit on Professional G Series tractors with ground-to-kill ignitions. It will not fit Professional 24-G tractors.

1. Put the wing mower in position on the left side of the tractor.
2. Put the ball joint of the drawbar assembly on the hitch pin that is fastened to the rear hitch on the tractor. Install the klik pin in the hitch pin.

**NOTE:** If the engine touches the ball joint, add two .531x1.062x.09 flat washers on each bolt between the rear hitch arms and the hitch plate.

3. Put the end of the stabilizer rod in the hole in the support plate that is fastened to the footboard on the tractor. Fasten the rod in position with the klik pin.

**NOTE:** If the tractor is equipped with a 60 inch rotary mower, use the long stabilizer rod. If the tractor is equipped with a 50 inch rotary mower, use the short stabilizer rod.

4. Connect the wing mower wiring harness to the tractor remote wiring harness.
5. Put the other end of the stabilizer rod in the hole in the rod bracket plate on the wing mower frame. Fasten the rod in position with the klik pin.

6. Position the inside front caster weldment parallel with the mower frame and retain with the 3/8x2.62 clevis pin and a klik pin.
7. To remove the mower, reverse Steps 2-6 above.

### 3.16 Installation of the Wing Mower on the Tractor for Towing.

 **WARNING:** Stop the engines.

1. Remove the stabilizer rod from the support plate and rod bracket plate. See Figure 1.
2. Put one end of the stabilizer rod between the fuel tank support brackets. If the long stabilizer rod is used, put the other end of the rod in the hole in the rod bracket plate. If the short stabilizer rod is used, put the other end of the rod in the hole in the height adjustment bracket.
3. Remove the klik pin and the clevis pin from the caster wheel that is locked in position. Turn the caster fork 90 degrees. Align the hole in the shaft of the caster fork with the holes in the caster support. Install the clevis pin and the klik pin. Repeat this instruction for the gauge wheel that is on the mower deck.
4. Close the fuel valve on the fuel tank by turning the valve clockwise.

**NOTE:** Do not disconnect the drawbar assembly from the tractor.

5. Start the tractor engine. Move the tractor forward. The wing mower will move in position to be towed behind the tractor.

 **WARNING:** Do not start the engine on the wing mower when the wing mower is being towed. Operate the wing mower only when the mower is in the mowing position. See Section 8.

6. To put the wing mower in the mowing position, repeat step 3 for the caster wheel and the gauge wheel.
7. Move the wing mower in position and connect the stabilizer rod as described in Section 3.15.
8. Open the fuel valve on the fuel tank by turning the valve counterclockwise.

 **WARNING:** Always close the fuel valve on the fuel tank when the engine is not running.



## SECTION 4

### STORAGE

#### 4.1 When the wing mower will not be operated for more than two months:

1. Do the daily and 25-hour maintenance, but do not add gasoline.
2. Clean the tractor. Paint or oil bare metal surfaces to prevent rust.

NOTE: Do not use harsh or abrasive cleaners on any painted surface. Do not allow gasoline or oil to remain on any silk screened surface.

3. Refer to the engine manual and prepare the engine for storage.
4. Clean and charge the battery. Charge the battery every three or four weeks while in storage.
5. Store in a cool, dry place.

#### 4.2 To use the wing mower again:

1. Refer to the engine manual and prepare the engine for service.
2. Charge the battery.
3. Put fresh, clean gasoline in the fuel tank.



## SECTION 5

### PROBLEM SOLVING

OBSERVATION	POSSIBLE CAUSE
1. No sound or motion when the ignition switch is turned to the "START" position.	Blown fuse Discharged battery Starting solenoid damaged Loose battery cable(s)
2. When the ignition switch is turned to "START", the solenoid "clicks" and the engine starter motor does not operate.	Discharged battery Battery cable connector(s) corroded Starter damaged
3. When the ignition switch is turned to "START", the starter operates but the engine does not start.	Relay or relay connection(s) Fuel tank empty Fuel valve turned off Engine spark plug fouled Engine failure -- see Engine Service Manual
4. Battery discharged.	Regulator-rectifier failure Fuse holder or battery Engine alternator failure Battery failure Ignition switch failure
5. Engine continues to run when the ignition switch is rotated to the "OFF" position.	Ground wire not connected Ignition switch failure
6. Engine runs rough or stops after it gets hot.	See Engine Service Manual
7. Fuse blows when starting engine.	Defective starter solenoid Shortage in wiring harness
8. Uneven cut.	Mower not level Uneven tire pressure Damaged gauge wheel Damaged mower frame Bent blade
9. Uncut grass.	Dull Blade Damaged blade Too low engine speed Mowing tall grass
10. Smoke from mower.	Spindle/blade locked Debris wedged against belt Loose belt
11. Engine slows when mower is engaged.	Damaged bearing in spindle assembly
12. Excessive noise.	Unbalanced blade(s) Idler bearings Damaged bearing in spindle assembly

## SECTION 6

### ILLUSTRATED PARTS AND PARTS LISTS

#### Adapter Kit

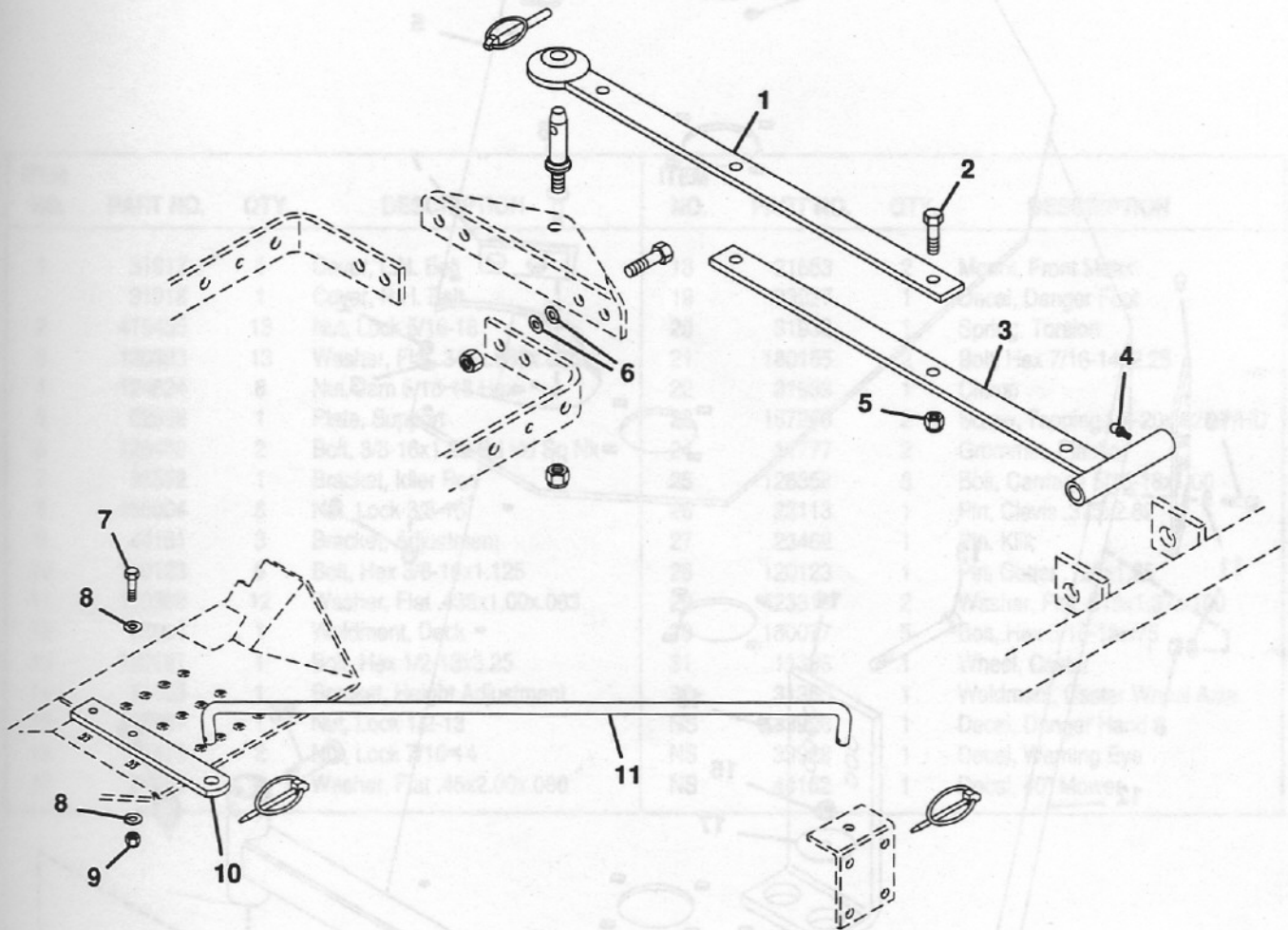

ITEM NO.	PART NO.	QTY.	DESCRIPTION	ITEM NO.	PART NO.	QTY.	DESCRIPTION
1	31872	1	Weldment, Rear Ball Joint	7	180128	2	Bolt, Hex 3/8-16x1.75
2	180179	2	Bolt, Hex 1/2-13x1.75	8	120388	4	Washer, Flat .438x1.000x.083
3	31874	1	Weldment, Rear Joint	9	456004	2	Nut, Lock 3/8-16
4	411027	1	Fitting, Lube 1/4-28	10	31926	1	Plate, Support
5	435507	2	Nut, Lock 1/2-13	11	31927	1	Rod, Stabilizer
6	120390	8	Washer, Flat .563x1.375x.109		31928	1	Rod, Stabilizer 60"

# Mower Deck

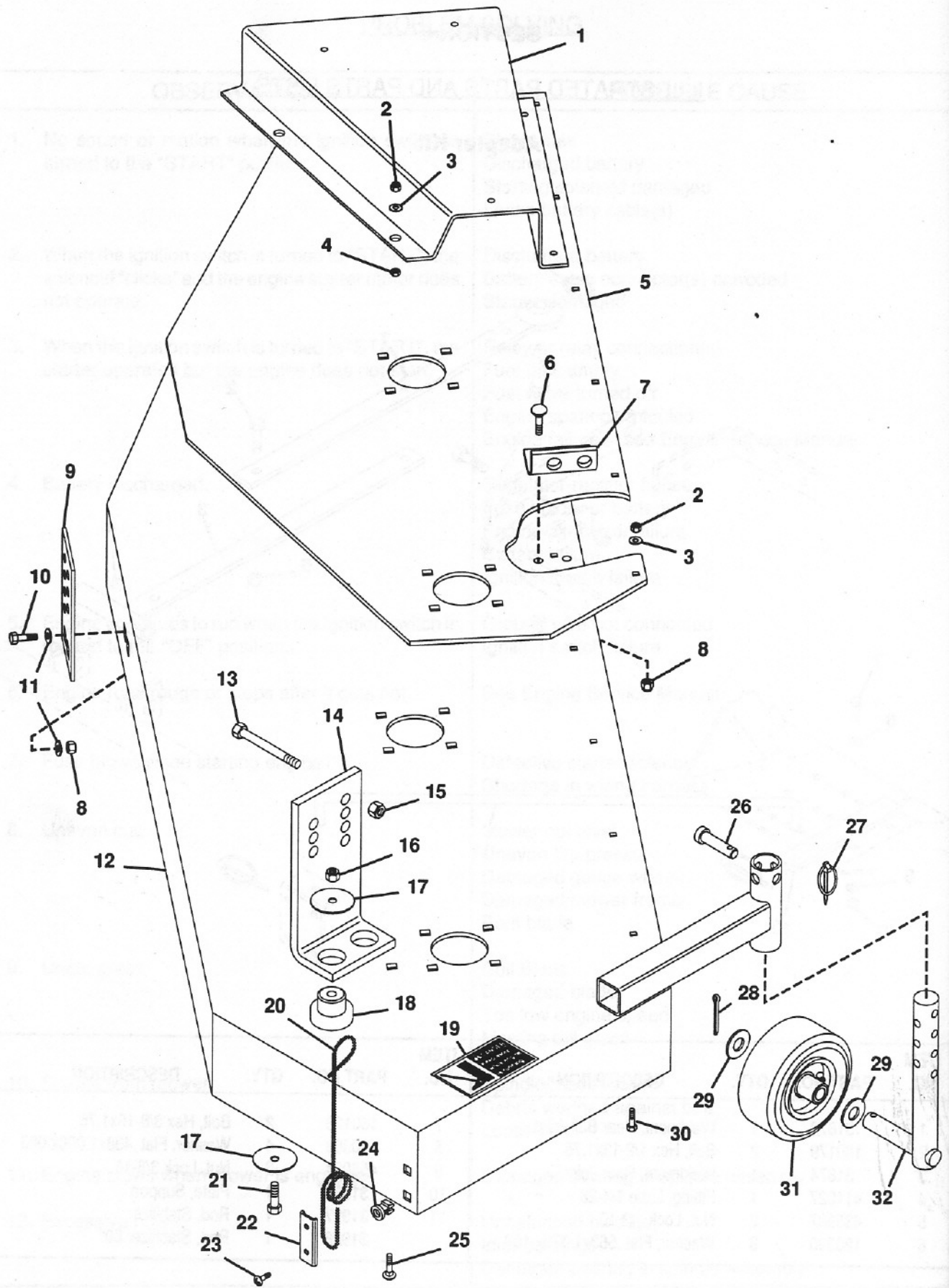



## Mower Deck

ITEM NO.	PART NO.	QTY.	DESCRIPTION	ITEM NO.	PART NO.	QTY.	DESCRIPTION
1	31917	1	Cover, L.H. Belt	18	21683	2	Mount, Front Motor
	31918	1	Cover, R.H. Belt	19	33927	1	Decal, Danger Foot
2	419455	13	Nut, Lock 5/16-18	20	31932	1	Spring, Torsion
3	120393	13	Washer, Flat .344x.688x.065	21	180155	2	Bolt, Hex 7/16-14x2.25
4	124824	8	Nut, Jam 5/16-18 Hex	22	31933	1	Clamp
5	52998	1	Plate, Support	23	167260	2	Screw, Tapping 1/4-20x.625 P/HD
6	126402	2	Bolt, 3/8-16x1.25 Rd Hd Sq Nk	24	11777	2	Grommet, Plastic
7	31892	1	Bracket, Idler Rod	25	126358	8	Bolt, Carriage 5/16-18x1.00
8	456004	8	Nut, Lock 3/8-16	26	22113	1	Pin, Clevis .375x2.62
9	44161	3	Bracket, Adjustment	27	23468	1	Pin, Klik
10	180123	6	Bolt, Hex 3/8-16x1.125	28	120123	1	Pin, Cotter .125x1.25
11	120388	12	Washer, Flat .438x1.00x.083	29	423315	2	Washer, Flat .813x1.37x.100
12	53001	1	Weldment, Deck	30	180077	5	Bolt, Hex 5/16-18x.75
13	180191	1	Bolt, Hex 1/2-13x3.25	31	11386	1	Wheel, Caster
14	44163	1	Bracket, Height Adjustment	32	31350	1	Weldment, Caster Wheel Axle
15	435507	1	Nut, Lock 1/2-13	NS	33926	1	Decal, Danger Hand
16	39413	2	Nut, Lock 7/16-14	NS	33928	1	Decal, Warning Eye
17	24995	4	Washer, Flat .45x2.00x.080	NS	44162	1	Decal, 40" Mower



# Mower Frame

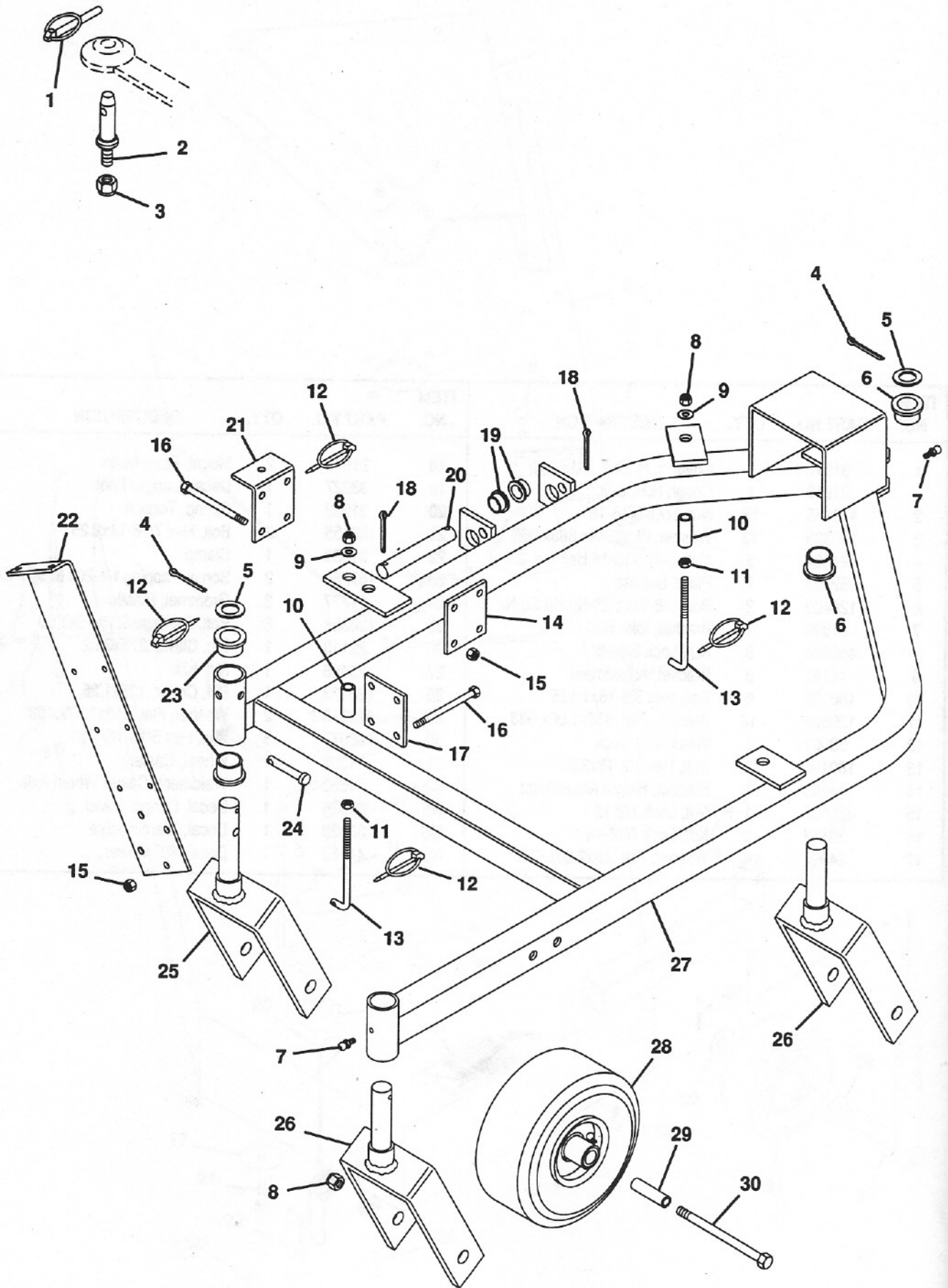

## Mower Frame

ITEM NO.	PART NO.	QTY.	DESCRIPTION	ITEM NO.	PART NO.	QTY.	DESCRIPTION
1	21979	1	Lynch Pin	17	35628	1	Plate, Attachment Clamp
2	31930	1	Pin, Rear Hitch	18	137228	2	Pin, Cotter .156x1.50
3	418692	1	Nut, Lock 5/8-11	19	10174	2	Bush., Flg. .764x1.47x.560 Ny.
4	137204	3	Pin, Cotter .125x1.500	20	31877	1	Pin, Pivot
5	19340	3	Race, Bearing Thrust	21	31880	1	Plate, Rod Bracket
6	22098	4	Bearing, Flanged	22	53204	1	Plate, Control
7	14406	2	Fitting, Lube 1/4-28	23	18355	2	Bush., Flg. 1.03x1.75x.750 Ny.
8	435507	6	Nut, Lock 1/2-13	24	22113	1	Pin, Clevis .375x2.62
9	120390	3	Washer, Flat .563x1.375x.109	25	43230	1	Weldment, Locking Caster
10	31883	3	Sleeve, Height Rod	26	31865	2	Weldment, Caster
11	120238	3	Nut, Jam 1/2-13 Hex	27	43222	1	Weldment, Frame
12	23468	6	Klik Pin	28	31870	3	Wheel, Wing Gauge
13	31921	3	Rod, Height Adjustment	29	31871	3	Bush., St. .512x.745x.06 Stl.
14	35497	1	Plate, Adjustment Clamp	30	445608	3	Bolt, Hex 1/2-13x5.50
15	456004	8	Nut, Lock 3/8-16	NS	24608	1	Decal, Gravely Logo
16	189304	8	Bolt, Hex 3/8-16x3.25				

# Mower Drive

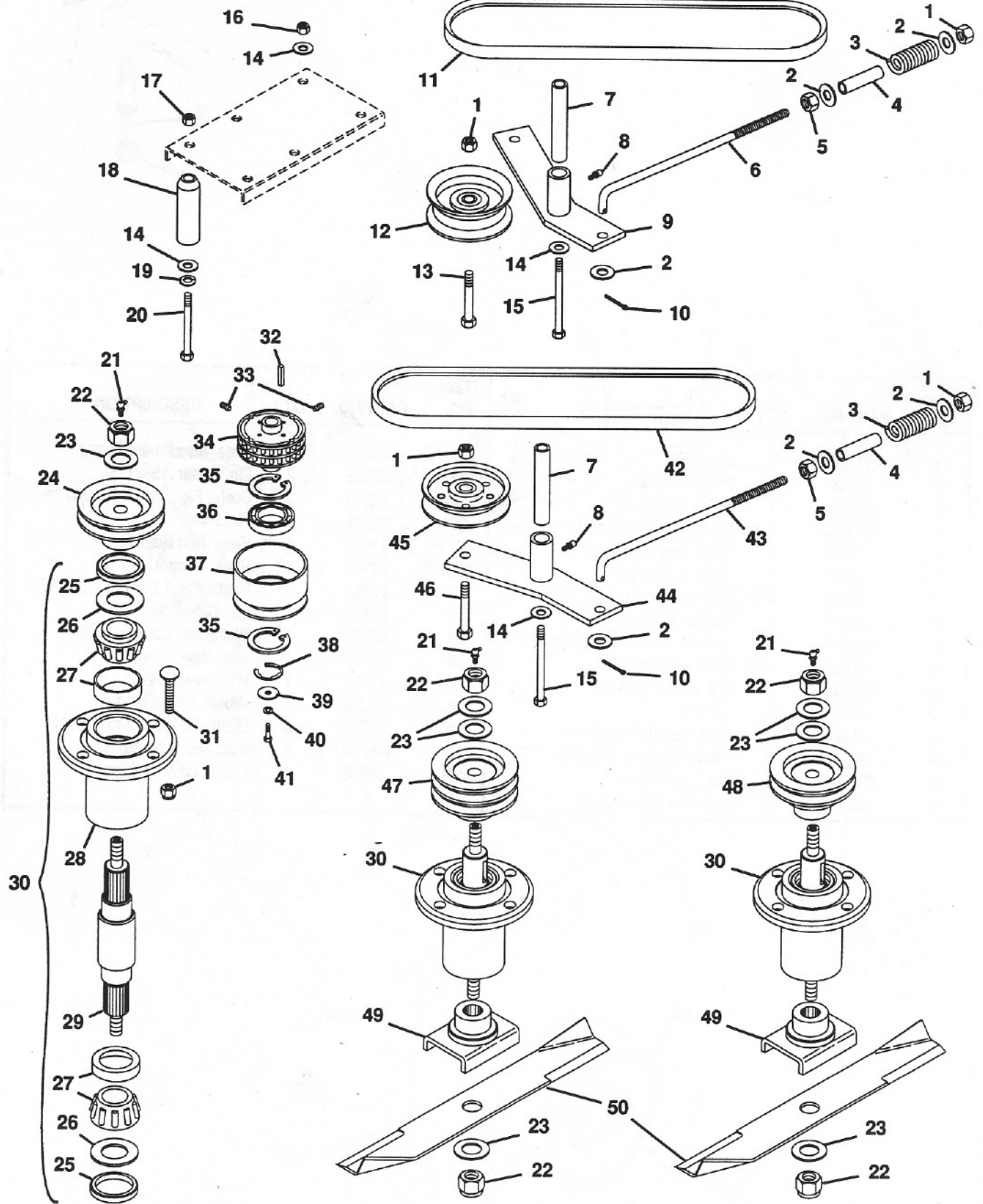



## Mower Drive

ITEM NO.	PART NO.	QTY.	DESCRIPTION	ITEM NO.	PART NO.	QTY.	DESCRIPTION
1	456004	16	Nut, Lock 3/8-16	26	20743	2	Washer, Flat .975x1.970x.030
2	120394	6	Washer, Flat .406x.812x.065	27	38199	2	Assembly, Bearing
3	31915	2	Spring, Idler Compression	28	21215	1	Housing, Bearing
4	21381	2	Sleeve, Spring For.-Rev.	29	21216	1	Shaft, Spindle
5	120377	2	Nut, Hex 3/8-16	30	21306	3	Spindle Assembly
6	31914	1	Rod, Idler R.H.	31	126406	12	Bolt, 3/8-16x1.375 Rd Hd Sq Nk
7	31911	2	Spacer, Engine	32	9213	1	Key, Square .25x1
8	14406	2	Fitting, Lube 1/4-28	33	102569	2	Screw, Set 1/4-20x.25 HSCP
9	31903	1	Weldment, Idler R.H.	34	31910	1	Clutch, Rotor Asm.
10	121224	2	Pin, Cotter .094x1.00	35	32143	2	Ring, Retaining Internal Spiral
11	31912	1	V-Belt, Driven	36	32144	1	Bearing, Ball 2.677x1.574x.590
12	31906	1	Pulley, V-Idler	37	32145	1	Housing, Clutch
13	180128	1	Bolt, Hex 3/8-16x1.75	38	32142	1	Ring, Retaining External Spiral
14	120393	7	Washer, Flat .344x.688x.065	39	44379	1	Washer, Special
15	417278	2	Bolt, Hex 5/16-18x4.75	40	120383	1	Washer, Lock 7/16 Reg.
16	413447	2	Nut, Lock 5/16-18	41	43317	1	Bolt, Hex M10x1.50x25mm
17	46363	1	Nut, Hex M8x1.25	42	25129	1	Belt, 40 Inch Mower
18	53200	2	Spacer, Support	43	31913	1	Rod, Idler L.H.
19	120214	2	Washer, Lock 5/16 Reg.	44	31900	1	Weldment, Idler L.H.
20	43316	2	Bolt, Hex M8x1.25x140mm	45	21060	1	Sheave, Idler
21	411019	3	Fitting, Lube 1/8 Pipe 90 Deg.	46	180130	1	Bolt, Hex 3/8-16x2.00
22	418692	6	Nut, Lock 5/8-11	47	31899	1	Pulley, Center
23	22545	8	Spring, Belleville	48	31898	1	Pulley, L.H.
24	25125	1	Sheave, Spindle	49	47684	3	Weldment, Blade Cradle
25	21211	2	Seal, Steel	50	46998	3	Blade, 50 Inch Mower

# Engine and Fuel System

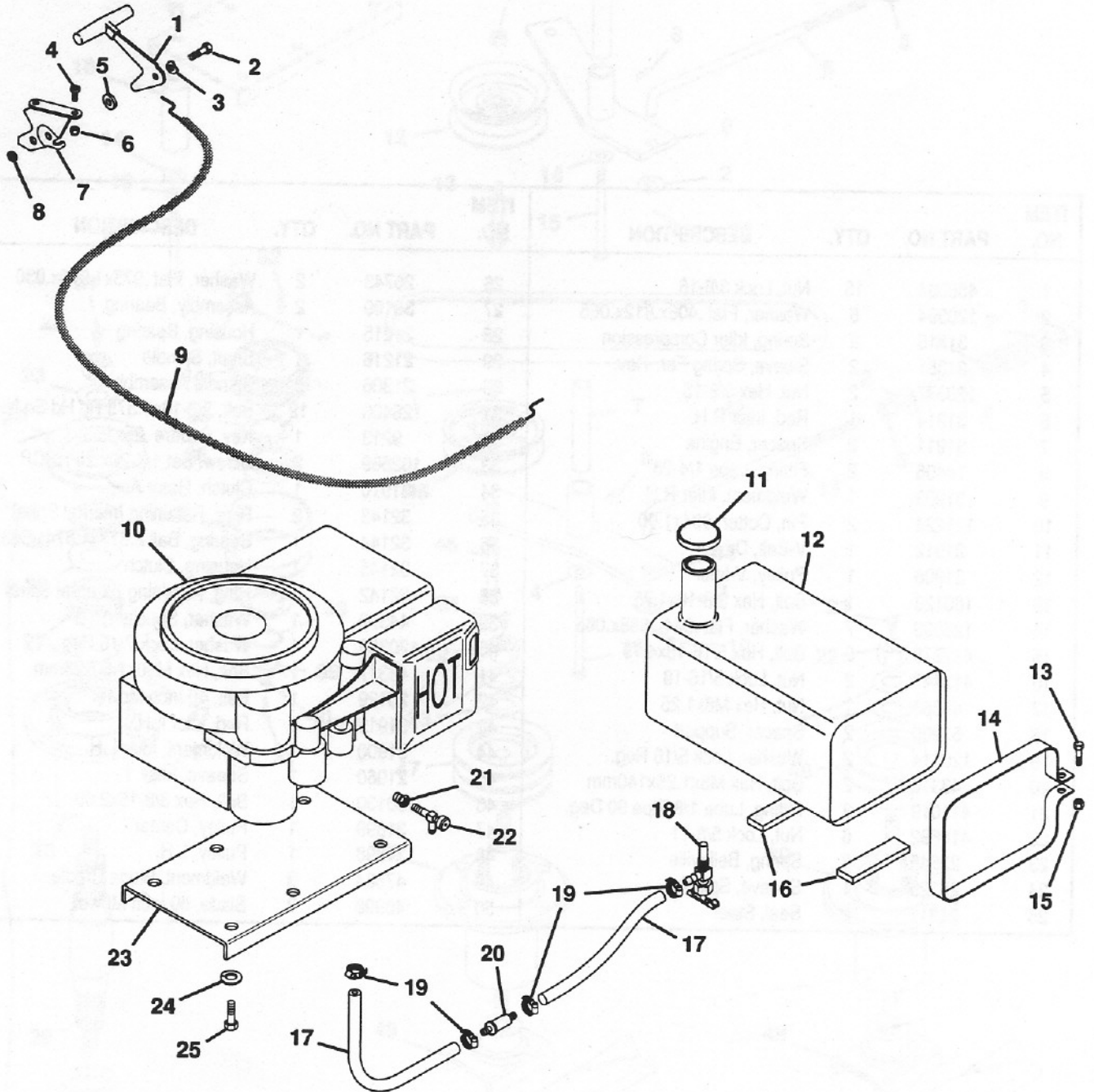

## Engine and Fuel System

ITEM NO.	PART NO.	QTY.	DESCRIPTION	ITEM NO.	PART NO.	QTY.	DESCRIPTION
1	11773	1	Assembly, Knob and Lever	14	31885	2	Strap, Wing Tank
2	181566	1	Bolt, Hex 1/4-28x.75	15	419455	2	Nut, Lock 5/16-18
3	11774	1	Washer, Spring	16	31884	2	Pad, Gas Tank
4	159920	2	Screw, Mach. 10-24x.50 PHD	17	21134	3 Ft.	Line, Fuel
5	11772	1	Washer, Friction	18	7354	1	Valve and Strainer
6	190254	2	Nut, Lock 10-24	19	32045	4	Clamp, Hose
7	11770	1	Bracket, Mounting	20	31848	1	Filter, Fuel
8	416430	1	Nut, Lock 1/4-28	21	41831	1	Adaptor, Oil Drain
9	50110	1	Assembly, Throttle Conduit	22	35329	1	Cock, Oil Drain
10	43324	1	Engine, 17 HP Kawasaki	23	31908	1	Plate, Engine
11	7289	1	Cap, Gas Tank	24	120214	2	Washer, Lock 5/16 Reg.
12	31886	1	Tank, Fuel	25	21913	2	Bolt, Hex M8x1.25 25mm
13	180081	2	Bolt, Hex 5/16-18x1.25				



# Electrical System

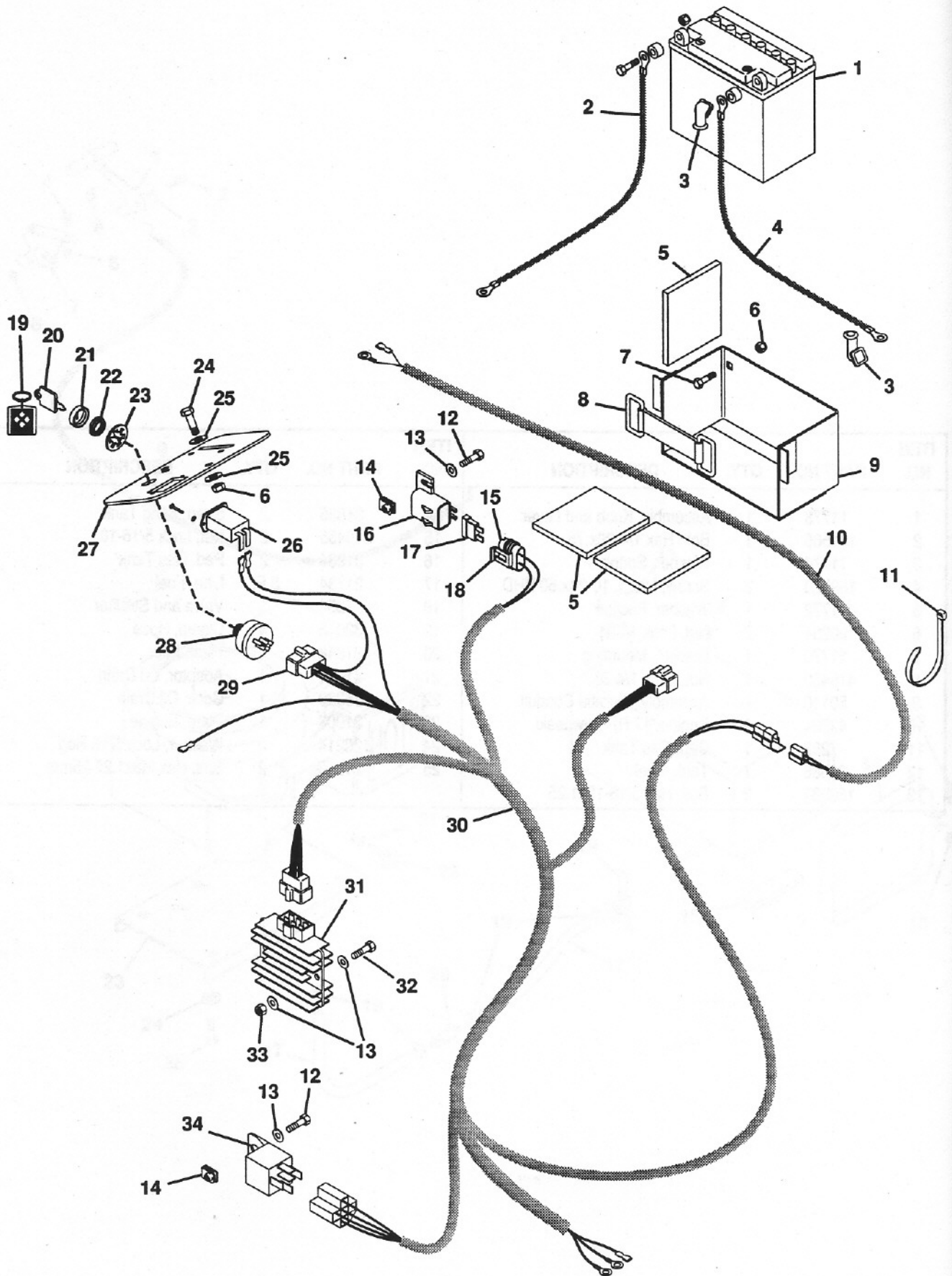

## Electrical System

ITEM NO.	PART NO.	QTY.	DESCRIPTION	ITEM NO.	PART NO.	QTY.	DESCRIPTION
1	41358	1	Battery, 12 Volt	18	45920	1	Assembly, Connector
2	53225	1	Cable, Negative	19	45842	1	Chain, Key
3	33847	2	Boot, Battery Cable	20	45488	2	Key, Ignition Switch
4	53224	1	Cable, Positive	21	45490	1	Boot, for 9/16 Switch Nut
5	41356	6	Pad, Battery	22	45497	1	Nut, 5/8-32 for Switch
6	419455	4	Nut, Lock 5/16-18	23	19667	1	Washer, Lock
7	180091	2	Bolt, Hex 5/16-18x2.50	24	180078	2	Bolt, Hex 5/16-18x.875
8	41359	1	Strap, Battery	25	120393	4	Washer, Flat .344x.688x.065
9	41313	1	Weldment, Battery Box	26	38256	1	Hourmeter
10	53229	1	Harness, Remote Wiring	27	53206	1	Panel, Silk Screened
11	44321	10	Tie Wrap, Black	28	52855	1	Switch, Ignition w/Ground
12	180020	2	Bolt, Hex 1/4-20x.750	29	38058	1	Connector
13	120392	6	Washer, Flat .281x.625x.065	30	53203	1	Harness, Wiring 40" Wing Mower
14	11676	2	Nut, Speed 1/4-20	31	52969	1	Regulator
15	45922	2	Terminal, for 14-16 Ga. Wire	32	180024	2	Bolt, Hex 1/4-20x1.25
16	45921	1	Cover	33	419454	2	Nut, Lock 1/4-20
17	45037	1	Fuse, 25 Amp	34	40216	1	Relay

## SECTION 7

### SPECIFICATIONS

Width of Cut:	40 in. (1016mm) Effective
Height of Cut:	1.5 in. (38mm) 2.00 in. (51mm) 2.50 in. (64mm) 3.00 in. (76mm) 3.50 in. (89mm) 4.00 in. (102mm) 4.50 in. (1.14mm)
Mower Deck Construction:	12-gauge (.120 in.) welded steel construction with a 3/16 in. (4.8mm) thick reinforcing support plate
Blades: Number	3
Description	17.0 in. (432mm) long, 1/4 in. (6.4mm) thick, high lift, heat-treated alloy steel
Frame:	Welded tubular steel
Weight:	442 lbs.
Width: Operating Position	75.0 in. (1905mm)
Towing Position	66.0 in. (1676mm)
Height:	15.0 in. (381mm)
Length: Operating Position	80.0 in. (2032mm)
Towing Position	74.0 in. (1880mm)
Engine: Manufacturer	Kawasaki
Model Number	FC540V
Type	AS04
Horsepower	17 H.P.
(at 3600 rpm)	
Speed (high idle)	3300 rpm
Crankcase Capacity	3.4 Pts. (1.4 L)
Air Cleaner	Dual element type
Drive:	Spindle assemblies are driven by two adjustable spring tensioned "HA" section V-belts
Clutch:	Automatic centrifugal of cast iron with 5.0 in. O.D. "A-B" section V-belt groove. Engagement speed is 2200 rpm.



SECTION 8

SET-UP INSTRUCTIONS

NOTE: Completely remove the wing mower and adapt kit from the shipping container.

8.1 Drawbar Assembly

The drawbar must be assembled to fit with the mower which is installed on the tractor. See Diagram 2. To assemble the drawbar to fit with the 60" mower...

Tires:	Size	4.10/3.50-4, 2 Ply
	Pressure	20 psi (138kN/m <sup>2</sup> )
	Description	Pneumatic, with 3/4 in. (19mm) ball bearings and grease fittings
Anti-scalp Wheel:	Size	6" x 2"
	Description	Semi-pneumatic
Spindle Assemblies:		1 in. (25mm) diameter spindle shafts, turning on tapered roller bearings, mounted in cast iron spindle housings
Discharge:		Right side, fixed discharge chute
Fuel Tank Capacity:		3.5 gals. U.S. (13.3 L)
Controls and Instrumentation:		Combined choke and throttle Ignition switch Hourmeter
Electrical System:		
	Charging System	15 Amp alternator
	Fuse	25 Amp
	Battery	12 Volt, Yuasa YB16L-B, 19 AH rating

DIAGRAM 2

# Wiring Diagram:

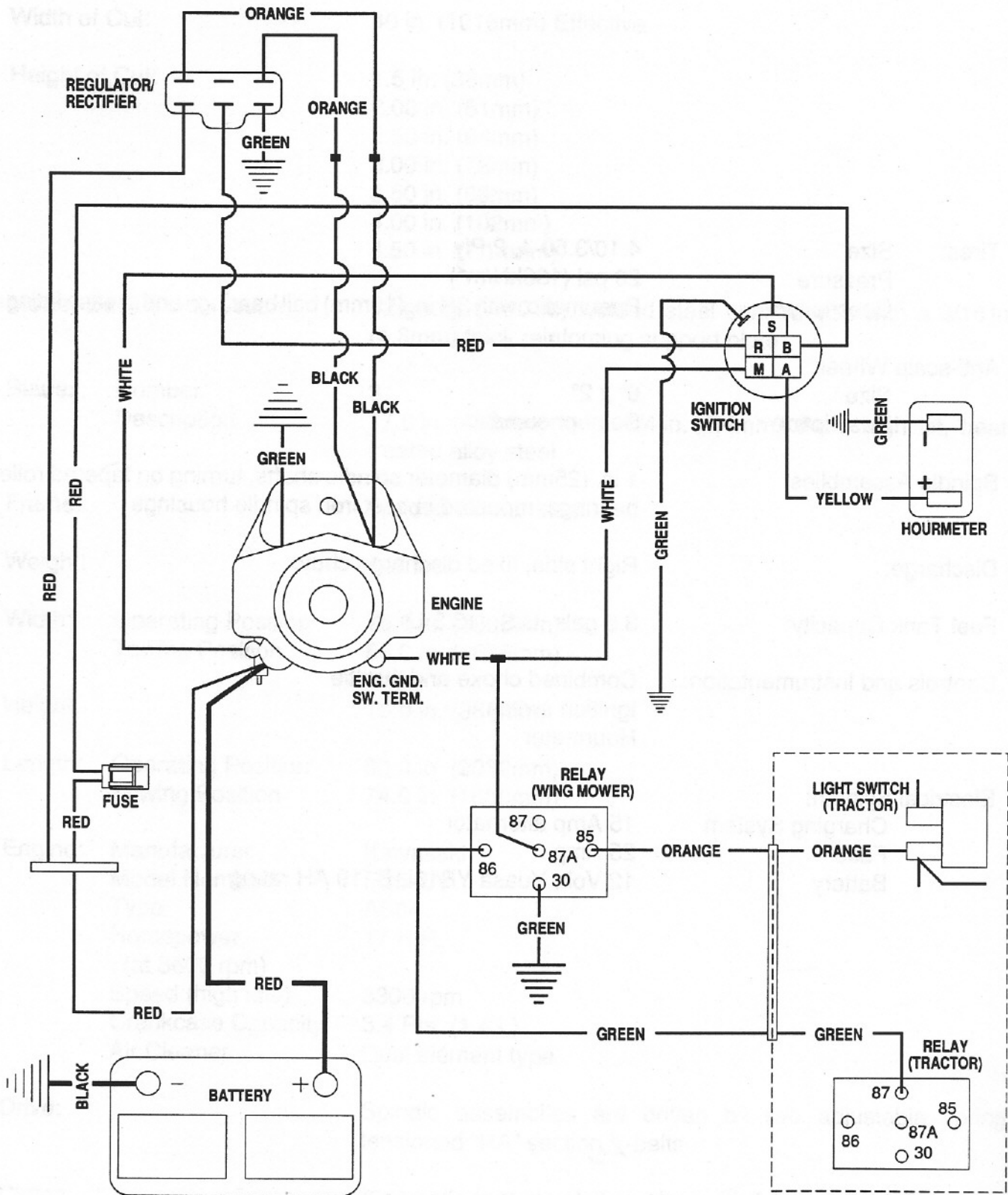

## SECTION 8

### SET-UP INSTRUCTIONS

**NOTE:** Completely remove the wing mower and adapter kit from the shipping container.

#### 8.1 Drawbar Assembly.

The drawbar must be assembled to fit with the mower which is installed on the tractor. See Diagram 2. To assemble the drawbar to fit with the 60" mower:

1. Align the hole in the end of the rear joint weldment with the hole in the center of the rear ball joint weldment.
2. Fasten the weldments together with the 1/2-13x1.75 hex bolts and the 1/2-13 lock nuts. Tighten the bolts to the torque of 60 ft. lbs. (82 N.m).
3. Fasten the wiring harness to the drawbar using the tie wraps provided.

To assemble the drawbar to fit with the 50" mower:

1. Align the hole in each end of the rear joint weldment with the hole in each end of the rear ball joint weldment.
2. Fasten the weldments together with the 1/2-13x1.75 hex bolts and the 1/2-13 lock nuts. Tighten the bolts to the torque of 60 ft. lbs. (82 N.m).
3. Fasten the wiring harness to the drawbar using the tie wraps provided.

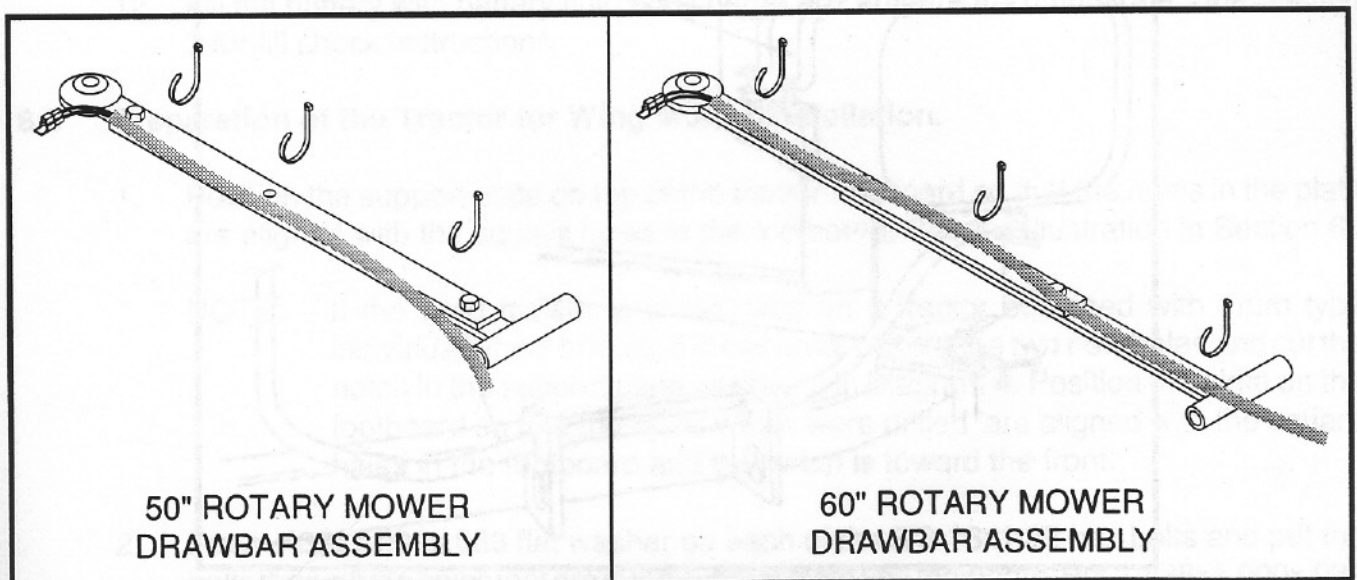
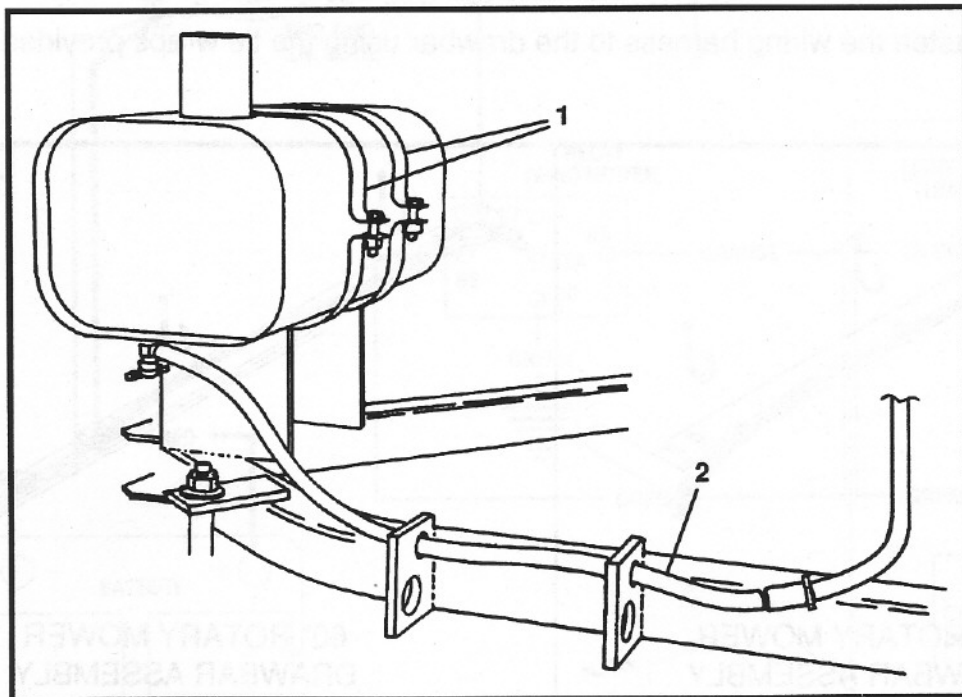

DIAGRAM 2



## 8.2 Assemble the Wing Mower.

1. Put a .813x1.37x.100 flat washer on the caster wheel axle weldment. Put the caster wheel (lube fitting away from spindle) on the axle. Retain with a .813x1.37x.100 flat washer and .125x1.25 cotter pin. See the illustration in Section 6.
2. Put a film of grease on the spindle of the caster wheel axle weldment. Slide the weldment into the tube on the mower deck from the bottom. Retain with a .375x2.62 clevis pin and a klik pin. See Figure 1.
3. Level the mower. See Section 3.
4. Set the fuel tank, centered, on the fuel tank bracket.
5. Put the wing tank straps around the fuel tank and the fuel tank bracket in line with the gas tank pads. Retain with the 5/16-18x1.25 bolts and 5/16-18 lock nuts. Tighten the bolts just enough to keep the fuel tank from moving. See Figure 4.
6. Fasten the fuel line to the fitting at the fuel tank with a hose clamp.
7. Put a plastic grommet in each hole on the corner of the mower deck. Put the torsion spring in position followed by the clamp. Retain with two 1/4-20x.625 pan head screws. See the illustration.
8. Put the rod bracket plate and adjustment clamp plate in position on the frame. See Diagram 3. Retain with four 3/8-16x3.25 bolts and 3/8-16 lock nuts.



1 - Wing Tank Straps  
2 - Fuel Line

FIGURE 4

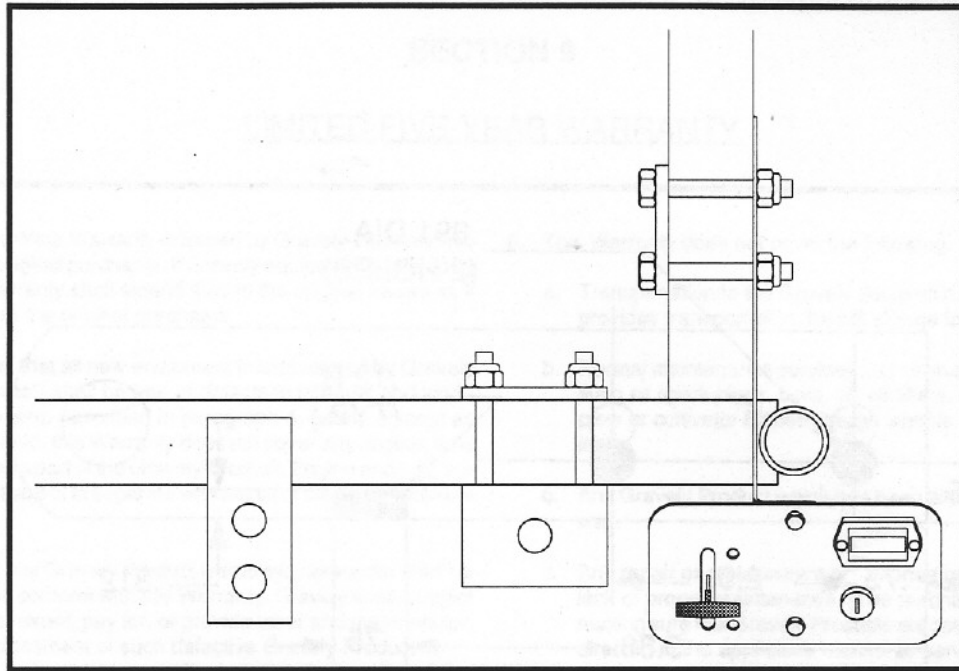

DIAGRAM 3

9. Put the .764x1.47x.560 flanged nylon bushings in the bracket holes on the mower frame. Put the drawbar assembly in position between the bushings. See Figure 2 for the orientation of the drawbar. Retain the drawbar with the pivot pin and two .156x1.50 cotter pins.
10. Adjust the air pressure in the tires on the caster wheels to 20 psi (138 KN/m<sup>2</sup>).
11. Put the control panel and plate in position on the frame. See Diagram 3. Retain with four 3/8-16x3.25 hex bolts and 3/8-16 lock nuts.
12. Fill the battery with battery fluid and charge at 2 ampere maximum rate. See Section 3 for fill check instructions.

### 8.3 Preparation of the Tractor for Wing Mower Installation.

1. Position the support plate on top of the tractor footboard so that the holes in the plate are aligned with the square holes in the footboard. See the illustration in Section 6.

**NOTE:** If the wing mower is to be used on a tractor equipped with drum type individual wheel brakes, it is necessary to drill the two new holes and cut the notch in the support plate as shown in Diagram 4. Position the plate on the footboard so that the holes which were drilled are aligned with the square holes in the footboard and the notch is toward the front.

2. Put a .438x1.000x.083 flat washer on each of the 3/8-16x1.25 hex bolts and put the bolts through the holes that are in the support plate and footboard. Put a .438x1.000x.083 flat washer and 3/8-16 lock nut on each bolt. Tighten the nuts to a torque of 25 ft.lbs. (34 N.m.).

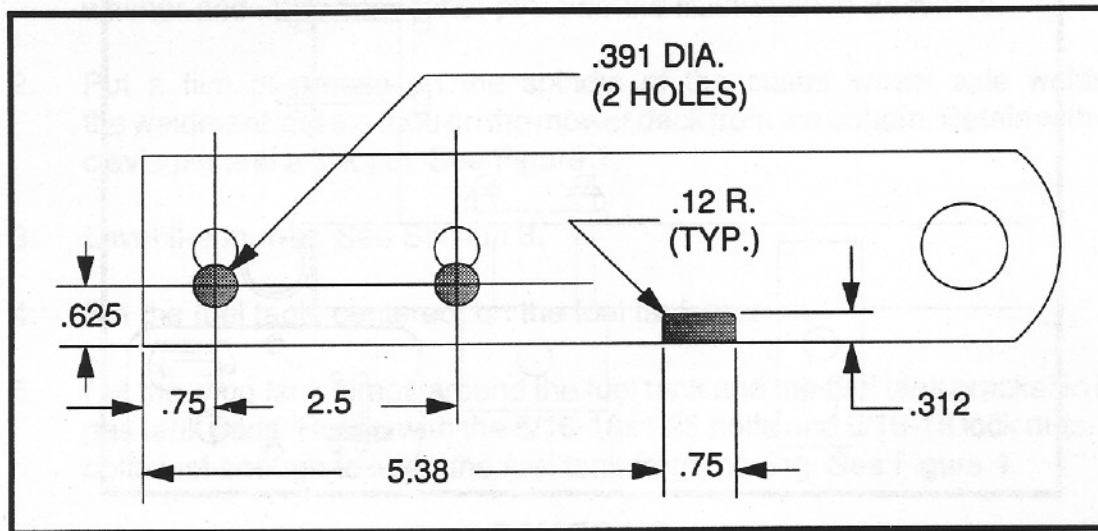

DIAGRAM 4

3. Put the threaded section of the hitch pin into the hole that is in the rear hitch plate on the tractor. Put the 5/8-11 lock nut on the hitch pin. Tighten the nut to a torque of 120 ft. lbs. (163 N.m).
4. Install the remote wiring harness. Position the harness on the tractor with the connector at the left rear near the hitch plate. Route the harness along the left hitch arm, across the axle, and parallel to the black hydraulic hoses until the loose end is near the steering column beneath the hood.
5. Raise the hood and disconnect the positive battery cable.
6. Connect the green wire on the remote wiring harness to the vacant position in the relay connector of the tractor wiring harness. The relay is located at the top of the left rear underhood area.
7. Connect the orange wire on the remote wiring harness to the switched terminal of the tractor light switch. (The one with the blue and black wires attached.)
8. Attached the remote wiring harness to the tractor using tie wraps at regular intervals.
9. Re-connect the positive battery terminal.



## SECTION 9

### LIMITED FIVE-YEAR WARRANTY

1. This Limited Five-Year Warranty is issued by Gravely International, Inc., only to the original purchaser. If Gravely equipment is leased by Gravely, this Warranty shall extend also to the original lessee as if such lessee were the original purchaser.
2. Gravely warrants that all new equipment manufactured by Gravely ("Gravely Products") shall be free of defects in material and workmanship for the term described in paragraph 4, below. Except as hereinafter provided, this Warranty does not cover any engine, tires or battery forming a part of the Gravely Product. Engine and tires are covered by and subject to separate warranties of the manufacturers thereof.
3. In the event that any Gravely Product warranted hereunder shall be defective or fail to conform with this Warranty, Gravely shall, subject to the provisions hereof, pay for, or provide labor and materials for, the repair or replacement of such defective Gravely Product.
4. This Warranty is for five years (60 months) from purchase date for Gravely Products used exclusively for personal, family or household purposes, and two years (24 months) for products used for other purposes (commercial use), excluding rental firms. Gravely products used for rental purposes will be warranted for 90 days. Repair of Gravely Products after the second year (24 months from date of purchase) shall be subject to a \$50.00 deductible for each repair. (After two years, Gravely agrees to repair or replace defective Gravely Products used exclusively for personal, family or household purposes only to the extent that the cost of such warranty covered repair or replacement exceeds \$50.00.)

Batteries are warranted by Gravely for a period of twelve (12) months only. If a battery shall fail within twelve (12) months of purchase, the replacement cost thereof shall be prorated over a twelve-month term based upon the number of months since purchase.
5. To obtain Warranty Service on a Gravely Product (including any battery or other component not manufactured by Gravely), use this procedure:
  - a. Notify the Gravely dealer from whom you purchased the equipment.
  - b. If you have moved and it is not convenient to notify the selling dealer, notify the nearest Gravely dealer. You should supply this dealer with a copy of the bill of sale as proof of the date of purchase.
  - c. Make arrangements to have the equipment delivered to the dealer (refer to paragraph 6 a., below).
  - d. If you have any questions concerning the Gravely Limited Warranty, they should be referred to:

Gravely International, Inc.  
One Gravely Lane  
Clemmons, NC 27012  
Attn: Customer Service Department
  - e. Warranty Service on Gravely Products must be performed by an authorized Gravely dealer.
6. This Warranty does not cover the following:
  - a. Transportation to the Gravely dealership. (If the Gravely dealer provides transportation, he will charge for such service.)
  - b. Normal maintenance services and normal replacement of items such as spark plugs, belts, oil, oil filters, air filters, and mower, plow or cultivator blades, gauge wheels, skids and other wear items.
  - c. Any Gravely Product which has been altered or modified in any way.
  - d. Any repair or replacement occasioned by customer neglect or lack of proper maintenance. (The purchaser is responsible for making sure that Gravely Products are operated and serviced as directed in the applicable manual or service instruction. Incorrect use or maintenance will void this Warranty.)
  - e. Any repair occasioned by the use of any attachment not approved by Gravely. (The use of any such unapproved attachment will void this Warranty.)
7. GRAVELY MAKES NO OTHER EXPRESSED OR IMPLIED WARRANTIES, OR WARRANTIES AS TO THE MERCHANTABILITY OR FITNESS FOR A PARTICULAR PURPOSE. ALL WARRANTIES ARE LIMITED IN DURATION TO THE TERMS SET OUT IN PARAGRAPH 4, ABOVE. GRAVELY SHALL HAVE NO LIABILITY FOR INCIDENTAL OR CONSEQUENTIAL DAMAGES RESULTING FROM THE BREACH OF ANY WARRANTY, INCLUDING, BUT NOT LIMITED TO, LIABILITY FOR INCONVENIENCE, RENTAL OR PURCHASE OF REPLACEMENT EQUIPMENT, OR FOR LOSS OF PROFITS OR OTHER COMMERCIAL LOSS.
8. Some states do not allow limitations on how long an implied warranty lasts, so the above statement may not apply to you. Some states do not allow the exclusion or limitation of incidental or consequential damages, so the above limitation or exclusion may not apply to you.
9. This Warranty gives you specific legal rights, and you may have other rights which vary from state to state.
10. A Gravely product registration card is supplied with each Gravely Product. Please complete the card and return it to Gravely at the address listed on the card. The equipment registration card will be used by Gravely for:
  - a. Recording date of purchase.
  - b. Notification of owners in compliance with the Consumer Product Safety Act, should any notification be necessary.The return of such card is necessary for your warranty to be effective.
11. This Warranty is not subject to change or modification by anyone, including Gravely dealers and no Gravely dealer is authorized to make any representations or promises on Gravely's behalf.

 **GRAVELY.**

One Gravely Lane, Clemmons, NC 27012