

# 32" SNOWBLOWER OPERATORS MANUAL

NOTE

Read this manual carefully and learn to operate and service your snowblower before using it.

To keep the warranty, the snowblower must be maintained and operated as directed in this manual.

All references to "left-side", "right-side", "front", and "back" are given from the operator's position.

Use the serial numbers to ensure prompt and correct service when ordering parts, requesting service, or making inquiries.

SNOWBLOWER SERIAL NUMBER \_\_\_\_\_



Look for this symbol to point out important safety precautions. It means -- ATTENTION! BECOME ALERT! YOUR SAFETY IS INVOLVED.

## CONTENTS

### 1. INSTRUCTIONS FOR SAFE OPERATION

### 2. OPERATING INSTRUCTIONS

### 3. SERVICE INSTRUCTIONS

### 4. STORAGE

### 5. ILLUSTRATED PARTS AND PARTS LIST

### 6. SET-UP INSTRUCTIONS

### 7. WARRANTY



## SECTION 1

### Instructions for Safe Operation

Improper use of this snowblower can injure people and damage the equipment. People using or servicing this snowblower must read and follow the instructions in this manual.

It is important to understand that this manual and any other Gravely instruction manuals do not cover every possible danger. It is impossible for Gravely to know of all possible dangers in operating and servicing the equipment.

The purchaser must give these instructions to the people operating and maintaining this snowblower. These people must use eye and foot protection.

#### 1.1 Preparation

1. Read the tractor and snowblower operator's manuals. Be familiar with all controls and follow the safety precautions outlined in these manuals. Know how to STOP the tractor and snowblower quickly in an emergency.
2. Inspect and clear the work area (prior to snow) of rocks, glass, metal, bones, and any other foreign objects that might be picked up and thrown or tangled in the snowblower. Stay alert for holes and other hidden hazards. Mark obstacles that will be hidden by snow.
3. Do not wear loose fitting clothing or accessories that might get caught in moving parts or on the controls. Keep hands, feet, hair, clothing, etc., away from moving parts.
4. Keep bystanders and pets removed from the work area, and a safe distance away.
5. Do not allow children to operate the equipment, nor allow adults to operate it without their having knowledge of safe operating practices.
6. Operate the snowblower from the operator's position just behind the handle bars.
7. Keep safety devices, interlocks, and shields in place at all times.
8. Put the PTO in the "OFF" position when the snowblower is not in use or is being transported.
9. Disengage power to the snowblower and STOP the engine before clearing the unit. NEVER CLEAN THE SNOWBLOWER WHILE THE ENGINE IS RUNNING.

10. After striking a foreign object, STOP the engine, put the PTO in the "OFF" position before inspecting for damage. Any damage must be repaired before restarting the equipment.
11. Never leave the equipment running when unattended-- always STOP engine and put the PTO in the "OFF" position before leaving the tractor.
12. Do not use the equipment in the dark without adequate lighting.
13. Maintain the snowblower in good condition. Keep the machine as directed in this manual.
14. Follow instructions listed on decals and in the operator's manuals.
15. Adjust the snowblower skids to lift the snowblower above gravel so that it does not get into the snowblower and is discharged.

#### 1.2 Operation:

1. Read the tractor operator's manual for safety and operating instructions to engage and disengage the snowblower. Know how to STOP the snowblower quickly in an emergency.
2. Put the PTO control in the "OFF" position, turn the ignition switch to the "OFF" position, and wait until the engine and other moving parts have stopped before leaving the operator's position at the handle bars.
3. Keep away from discharge chute.
4. Direct snowblower discharge away from windows, cars, buildings, and people which could be struck by objects thrown with the snow.
5. Operate tractor engine inside only to move the equipment into or out of storage.
6. Go slowly on slick surfaces. Travel across slopes.
7. Use low gear, high engine speed and put the PTO in the "ON" position before moving into the snow.
8. Allow the snowblower to clear of snow before placing the PTO control in the "OFF" position. Stop the engine and remove remaining snow and ice before putting the equipment in storage.
9. Always look behind before backing.

## SECTION 2

### Operating Instructions

#### 2.1 Preparation:

1. Read the tractor and snowblower operator's manuals. Be familiar with all controls and follow the safety precautions outlined in these manuals. Know how to STOP the tractor and snowblower quickly in an emergency. See Figure 1.
2. Check the oil level in the gear case. Add oil to maintain level with fill hole. See Section 3.
3. Service tractor as described in the tractor operator's manual.

 **CAUTION:** Moving parts can amputate finger, toes, and cause serious injury.

- a. Before servicing any attachment:
  - (1) Disengage power to attachment.
  - (2) Shut off engine.
  - (3) Make sure attachment parts have stopped revolving.
  - (4) Disconnect engine spark plug cable to prevent accidental restart.
- b. Keep children, bystanders, and pets out of the working area.
- c. Keep hands, feet, and clothing away from power driven parts.
- d. Snow is best removed as soon as possible after it has fallen.
- e. Snow should be discharged with the direction of the wind.
- f. Adjust the skids and scraper blade according to the instructions in Section 3.



## 2.2 Operation:

1. Adjust the deflector angle using the "T" handle, at the operator's left. Raising the deflector will cause snow to be thrown further. Lowering the deflector will shorten the distance that the snow is thrown. Turn the "T" handle to adjust the deflector; PUSH to lower the deflector; PULL to raise the deflector. A quarter turn of the handle will lock the deflector in position.
2. Rotate the chute crank to turn the discharge chute, so that the snow will be thrown in the desired direction.

**⚠ CAUTION:** The auger and gearcase are protected by a slip clutch designed to slip if a solid object enters the auger. The auger will start running when the obstruction is cleared if the PTO control is in the "ON" position.

3. For maximum snow removal and discharge, operate the engine at full throttle and regulate the travel speed with the Gear Control Lever. Put the range control in the "Lo" position.

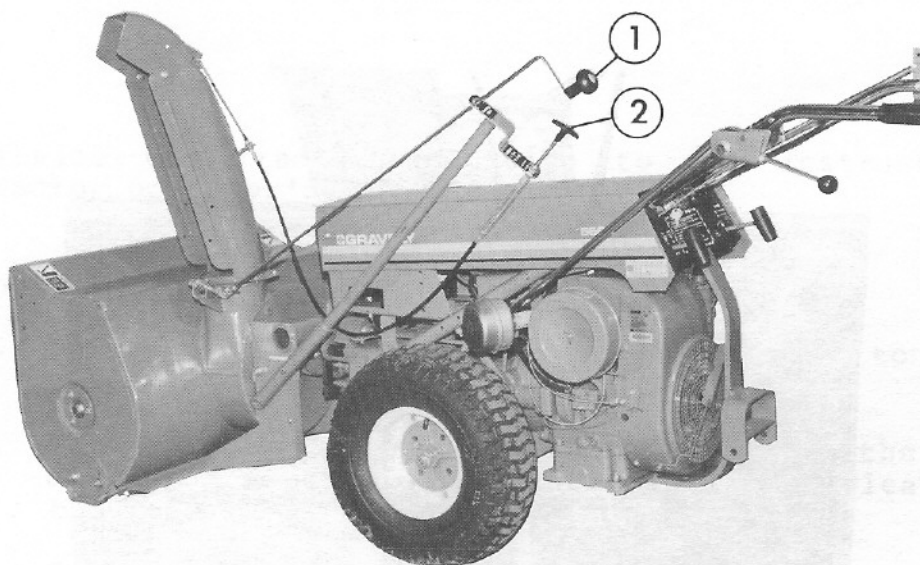

- 1 - Discharge Chute Control  
2 - Chute Deflector Control

FIGURE 1

85045

## SECTION 3

### Service Instructions

- 3.1 Check gear case oil level periodically. Position snowblower on a flat surface. Oil level must be up to oil fill hole. Change oil every 25 hours or once each season, whichever comes first. Use SAE 80W-90 gear oil. See Figure 2.
- 3.2 Oil the discharge chute base shown in Figure 3 approximately once a season.
- 3.3 Skid Adjustment:
1. When operating on a rough surface or over gravel, lower the skids so that the snowblower will be raised above the gravel or ground.
  2. Adjust by loosening the mounting bolts, sliding to the desired position, and retightening the bolts.
- 3.4 Scraper Blade Adjustment:
- When the scraper blade has worn near the brace, loosen the mounting bolts and advance the blade and retighten the bolts. Replace the blade when all the adjustment has been used.

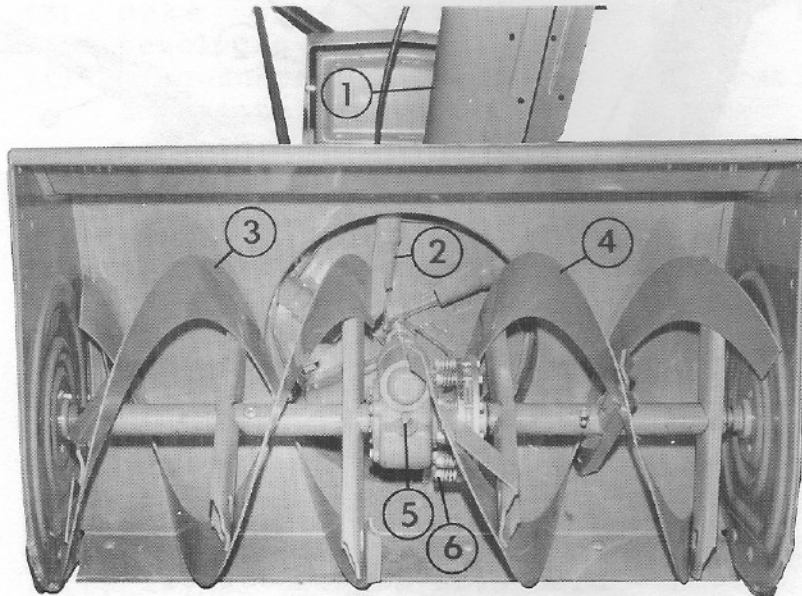

85046

- |                     |                   |
|---------------------|-------------------|
| 1 - Discharge Chute | 4 - Left Auger    |
| 2 - Fan             | 5 - Oil Fill Plug |
| 3 - Right Auger     | 6 - Slip Clutch   |

FIGURE 2



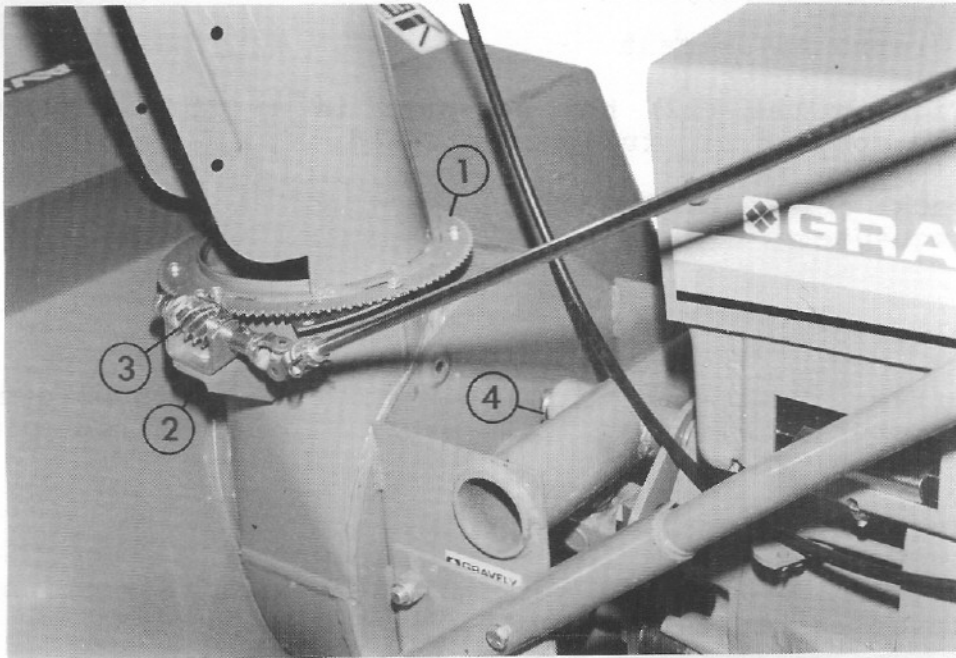

85047

- 1 - Discharge Chute Base
- 2 - Nut
- 3 - Worm
- 4 - Self-Locking Pin

FIGURE 3

3.5 Service the tractor according to the instructions in the tractor operator's manual.

3.6 Chute Crank Adjustment:

1. Loosen the nut securing the worm clevis to the bracket. See Figure 3.
2. Position the worm so that it aligns with the teeth on the discharge chute so that there is little clearance between the worm and the teeth.
3. Tighten the nut.
4. Operate the chute crank.
5. Readjust if it does not rotate easily.

### 3.7 Slip Clutch Adjustment

1. Tighten the (12) hex locknuts in a cross sequence until the springs are fully compressed.
2. Back off one (1) full turn on each nut in a cross sequence.

### 3.8 Installation:

1. Drive the tractor to the rear of the snowblower. The tractor must be fitted with a quick hitch pin. See Figures 3 and 4.
2. Turn the engine off.
3. Put the tractor in gear and place the direction control lever in the forward position.
4. Put the PTO control in the "ON" position.
5. Slide the snowblower onto the quick hitch pin and at the same time, guide the U-joint assembly onto the PTO shaft.
6. Put the self-locking pin in the quick hitch pin.
7. Mount the locking strap and two spacers on the left side of the quick hitch adapter with two 1/2-13x4-1/2" bolts. The top spacer goes through the lock strap to keep the snowblower from rotating.
8. Put the PTO control in the "OFF" position.
9. Put the direction control lever in the neutral position.
10. Raise and lock the kick stand.

### 3.9 Removal:

1. Turn off the engine.
2. Lower and lock the kick stand.
3. Remove the locking strap and spacers.
4. Remove the pin in the quick hitch pin.
5. Pull the snowblower off the quick hitch pin or back the tractor away from the snowblower.

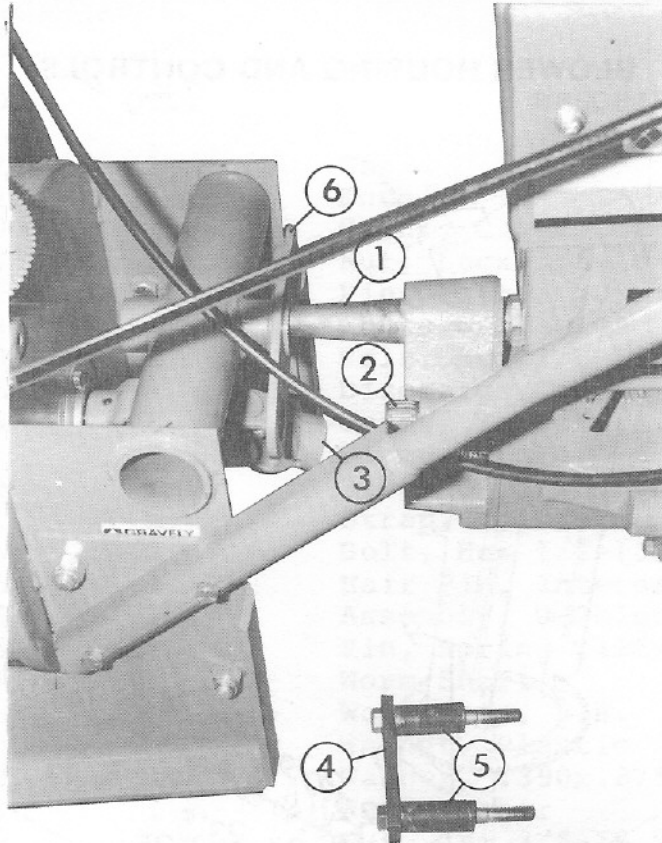

85048

- |                      |                   |
|----------------------|-------------------|
| 1 - Quick Hitch Pin  | 4 - Locking Strap |
| 2 - PTO Shaft        | 5 - Spacers       |
| 3 - U-Joint Assembly | 6 - Lock Strap    |

FIGURE 4

#### SECTION 4

##### Storage

- 4.1 Clean and lubricate the snowblower as directed in Section 3.
- 4.2 Inspect parts for damage and wear.
- 4.3 Touch up unpainted areas with paint.
- 4.4 Place in a cool, dry area.



SECTION 5

Illustrated Parts and Parts List

**BLOWER HOUSING AND CONTROLS**

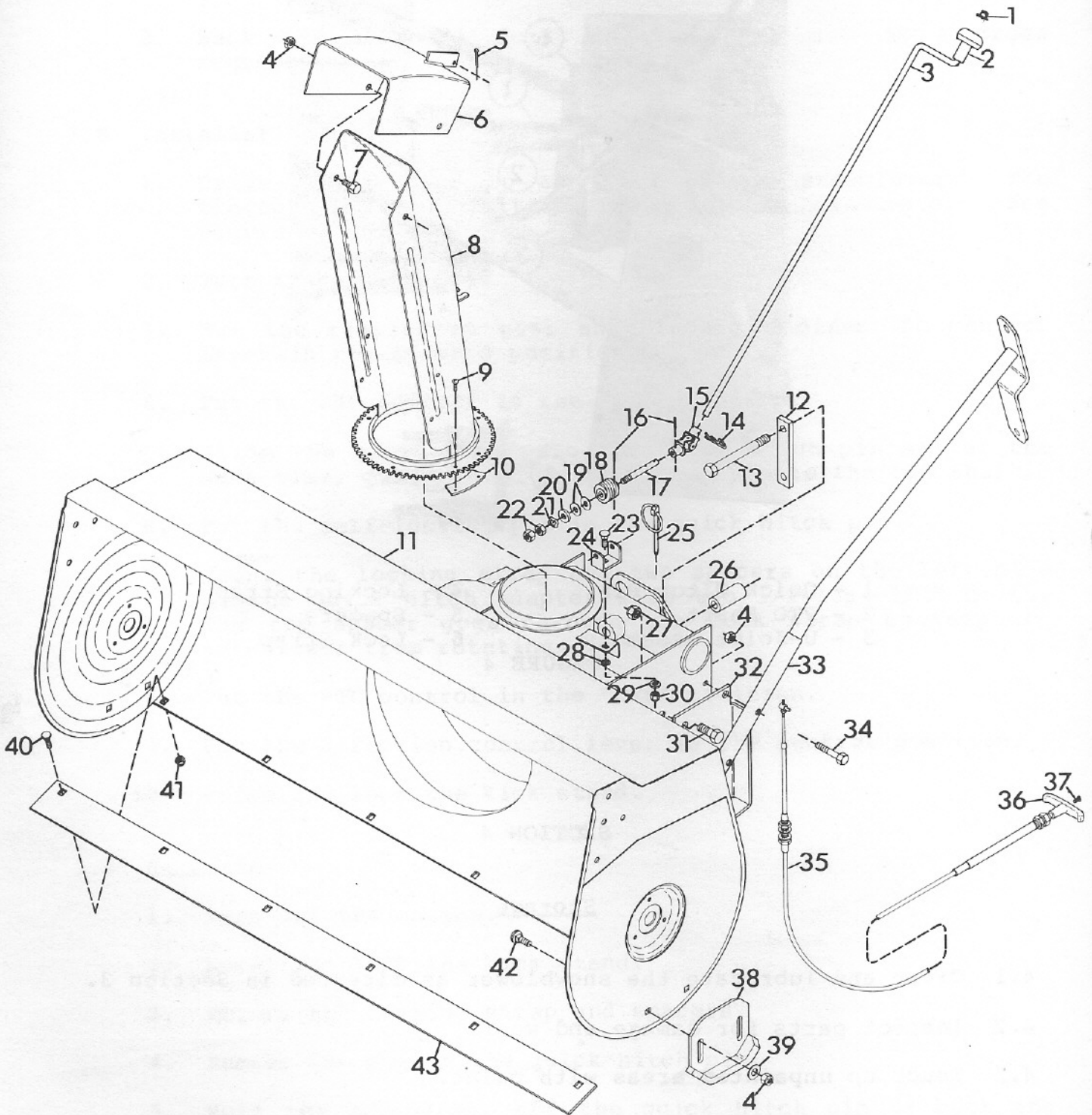

## BLOWER HOUSING AND CONTROLS

ITEM NO.	PART NO.	QTY.	DESCRIPTION
1	36903	1	Cap
2	36902	1	Knob
3	38849	1	Crank, Chute Control
4	413534	8	Nut, Lock 3/8-16
5	121222	1	Pin, Cotter .09x.75
6	36893	1	Chute Deflector
7	180120	2	Bolt, Hex 3/8-16x.75
8	38835	1	Discharge Chute
9	38836	8	Screw, Taptite #10-24x.375
10	36894	4	Clamp, Chute
11	38829	1	32" Sno Thro Housing
12	35053	1	Strap, Locking
13	433156	2	Bolt, Hex 1/2-13x4.50
14	36075	1	Hair Pin, Internal
15	39376	1	Assembly, U-Joint
16	415236	2	Pin, Spring .125x.750
17	38841	1	Worm Shaft
18	38839	1	Worm Gear, L.H.
19	38840	2	Washer, Plastic .390x.875x.0
20	38842	1	Washer, .390x.875x.7 Ga.
21	38843	1	Wave Washer
22	124829	2	Nut, Jam 3/8-16 Hex
23	126216	1	Bolt, Carriage 5/16-18x.75
24	38837	1	Worm Clevis
25	21244	1	Pin, Self-Locking
26	35054	2	Spacer
27	435507	4	Nut, Lock 1/2-13
28	138489	1	Washer, Lock 3/8 Ext. Th. TYA
29	120214	1	Washer, Lock 5/16 Reg.
30	120376	1	Nut, Hex 5/16-18
31	180175	4	Bolt, Hex 1/2-13x1.25
32	40463	1	Bracket, Support
33	38846	1	Crank Support
34	180130	2	Bolt, Hex 3/8-16x2.00
35	36898	1	Cable, Control
36	36910	1	Handle, Tee
37	36911	1	Screw, Machine 10-32x.50
38	40825	2	Runner, Skid Shoe
39	120394	4	Washer, Flat .406x.812x.065
40	126353	6	Bolt, 5/16-18x.875 Rd Hd Sq Nk
41	413447	6	Nut, Lock 5/16-18
42	120915	4	Bolt, 3/8-16x1.00 Rd Hd Sq Nk
43	40457	1	Scraper Blade
NS	24608	1	Decal, Gravely Logo
NS	33927	2	Decal, Danger Foot
NS	33926	1	Decal, Danger Hand
NS	38847	1	Decal, Chute
NS	38848	1	Decal, Deflector

# GEARCASE AND RAKE

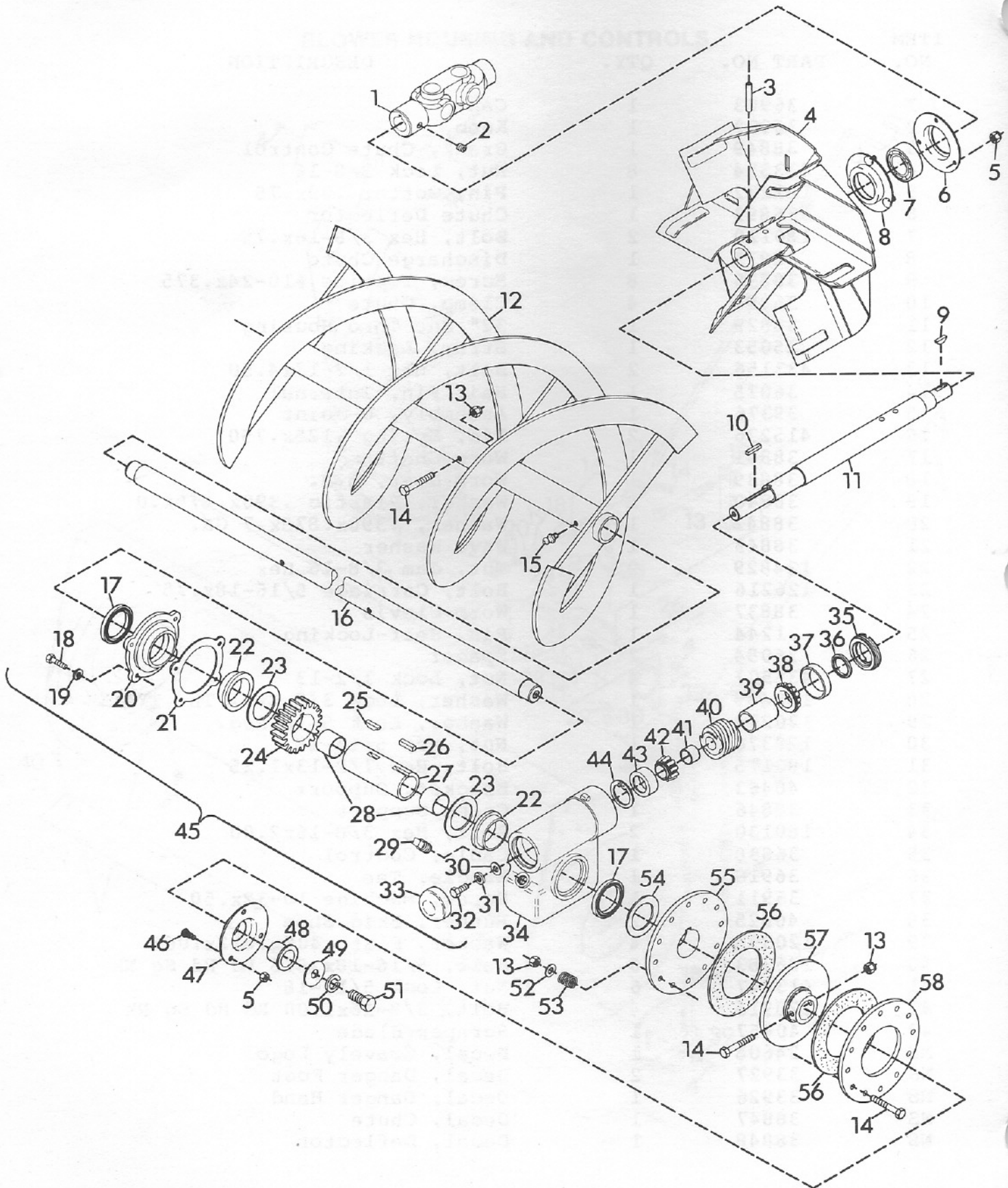



## GEARCASE AND RAKE

ITEM NO.	PART NO.	QTY.	DESCRIPTION
1	38834	1	Assembly, U-Joint
2	102592	1	Screw, Set 3/8-16x.375
3	36869	2	Pin, Roll 5/16x1.75
4	37542	1	Fan
5	424215	9	Nut, Lock 1/4-20
6	36874	1	Bearing, Flange
7	36876	1	Bearing, Ball
8	36875	1	Bearing, Flange
9	120502	1	Key, Woodruff 3/16x7/8 HRD #11
10	36230	1	Key, Straight SAE 1035
11	38817	1	Worm Shaft
12	38832	1	Rake, Right 32"
	38833	1	Rake, Left 32"
13	413447	15	Nut, Lock 5/16-18
14	180087	15	Bolt, Hex 5/16-18x2.00
15	411027	4	Fitting, Lube 1/4-28
16	38831	1	Shaft, 32" Rake
17	36863	2	Seal
18	180021	4	Bolt, Hex 1/4-20x.875
19	121753	4	Washer, Lock 1/4 Ext Th TYA
20	36861	1	Cover, Gearcase
21	36862	1	Gasket
22	36860	2	Bushing, Flange 1.62x1.87x11
23	36859	2	Washer, 1.625x2.50x.012
24	36858	1	Gear, Worm
25	38820	1	Key, Feather
26	37536	1	Key, Straight
27	37530	1	Gearcase Shaft
28	37532	2	Bushing, Sleeve
29	35945	1	Pipe Plug
30	120393	1	Washer, Flat .344x.688x.065
31	120379	1	Washer, Lock 5/16 SP
32	180077	1	Bolt, Hex 5/16-18x.75
33	36856	1	Cap, Dust
34	37524	1	Gearcase
35	37529	1	Adjustment Plug
36	37528	1	Seal
37	37527	1	Bearing Cup
38	37526	1	Bearing Cone
39	36352	1	Bearing Spacer
40	36853	1	Worm
41	36852	1	Spacer, Bearing
42	18446	1	Bearing Cone
43	18445	1	Bearing Cup
44	36921	1	Ring, Snap Internal 1.781
45	37978	1	Gearcase Assembly
46	36873	6	Bolt, Rib Neck 1/4-20x.5
47	36871	2	Support, Bearing
48	36872	2	Bushing, Flange 1x1.12x.625
49	36840	2	Washer, Flat .515x1.441x.1
50	131101	2	Washer, Lock 1/2 SP Heavy

## GEARCASE AND RAKE

ITEM NO.	PART NO.	QTY.	DESCRIPTION
51	180173	2	Bolt, Hex 1/2-13x1
52	120386	12	Washer, Flat
53	12871	12	Spring, Compression
54	37535	1	Washer
55	37537	1	Driver
56	37538	2	Friction Disc
57	37539	1	Driven Plate
58	37540	1	Pressure Plate

## SECTION 6

### Set-Up Instructions

- 6.1 Remove the snowblower from the shipping container.
- 6.2 Mount the mast to the left side of the snowblower frame with 3/8-16x2 bolts, 3/8 lock washers, and 3/8-16 nuts.
- 6.3 Remove the clamps from the discharge chute.
- 6.4 Put a film of grease on the bottom of the discharge chute.
- 6.5 Set the discharge chute on the blower outlet aligning the teeth with the worm. Replace the clamps.
- 6.6 Slide the chute crank from the rear through the top hole in the mast support.
- 6.7 Slide the front end of the crank into the U-joint of the worm gear assembly and secure with a hair pin cotter.



## LIMITED FIVE-YEAR WARRANTY

1. This Limited Five-Year Warranty is issued by Gravely International, Inc., only to the original purchaser. If Gravely equipment is leased by Gravely, this Warranty shall extend also to the original lessee as if such lessee were the original purchaser.
2. Gravely warrants that all new equipment manufactured by Gravely ("Gravely Products") shall be free of defects in material and workmanship for the term described in paragraph 4, below. Except as hereinafter provided, this Warranty does not cover any engine, tires or battery forming a part of the Gravely Product. Engine and tires are covered by and subject to separate warranties of the manufacturers thereof.
3. In the event that any Gravely Product warranted hereunder shall be defective or fail to conform with this Warranty, Gravely shall, subject to the provisions hereof, pay for, or provide labor and materials for, the repair or replacement of such defective Gravely Product.
4. This Warranty is for five years (60 months) from purchase date for Gravely Products used exclusively for personal, family or household purposes, and two years (24 months) for products used for other purposes (commercial use), excluding rental firms. Gravely products used for rental purposes will be warranted for 90 days. Repair of Gravely Products after the second year (24 months from date of purchase) shall be subject to a \$50.00 deductible for each repair. (After two years, Gravely agrees to repair or replace defective Gravely Products used exclusively for personal, family or household purposes only to the extent that the cost of such warranty covered repair or replacement exceeds \$50.00.)  
  
Batteries are warranted by Gravely for a period of twelve (12) months only. If a battery shall fail within twelve (12) months of purchase, the replacement cost thereof shall be prorated over a twelve-month term based upon the number of months since purchase.
5. To obtain Warranty Service on a Gravely Product (including any battery or other component not manufactured by Gravely), use this procedure:
  - a. Notify the Gravely dealer from whom you purchased the equipment.
  - b. If you have moved and it is not convenient to notify the selling dealer, notify the nearest Gravely dealer. You should supply this dealer with a copy of the bill of sale as proof of the date of purchase.
  - c. Make arrangements to have the equipment delivered to the dealer (refer to paragraph 6 a., below).
  - d. If you have any questions concerning the Gravely Limited Warranty, they should be referred to:  
  
Gravely International, Inc.  
One Gravely Lane  
Clemmons, NC 27012  
Attn: Customer Service Department
  - e. Warranty service on Gravely Products must be performed by an authorized Gravely dealer.
6. This Warranty does not cover the following:
  - a. Transportation to the Gravely dealership. (If the Gravely dealer provides transportation, he will charge for such service.)
  - b. Normal maintenance services and normal replacement of items such as spark plugs, belts, oil, oil filters, air filters, and mower, plow or cultivator blades, gauge wheels, skids and other wear items.
  - c. Any Gravely Product which has been altered or modified in any way.
  - d. Any repair or replacement occasioned by customer neglect or lack of proper maintenance. (The purchaser is responsible for making sure that Gravely Products are operated and serviced as directed in the applicable manual or service instruction. Incorrect use or maintenance will void this Warranty.)
  - e. Any repair occasioned by the use of any attachment not approved by Gravely. (The use of any such unapproved attachment will void this Warranty.)
7. GRAVELY MAKES NO OTHER EXPRESS OR IMPLIED WARRANTIES, OR WARRANTIES AS TO THE MERCHANTABILITY OR FITNESS FOR A PARTICULAR PURPOSE. ALL WARRANTIES ARE LIMITED IN DURATION TO THE TERMS SET OUT IN PARAGRAPH 4, ABOVE. GRAVELY SHALL HAVE NO LIABILITY FOR INCIDENTAL OR CONSEQUENTIAL DAMAGES RESULTING FROM THE BREACH OF ANY WARRANTY, INCLUDING, BUT NOT LIMITED TO, LIABILITY FOR INCONVENIENCE, RENTAL OR PURCHASE OF REPLACEMENT EQUIPMENT, OR FOR LOSS OF PROFITS OR OTHER COMMERCIAL LOSS.
8. Some states do not allow limitations on how long an implied warranty lasts, so the above statement may not apply to you. Some states do not allow the exclusion or limitation of incidental or consequential damages, so the above limitation or exclusion may not apply to you.
9. This Warranty gives you specific legal rights, and you may have other rights which vary from state to state.
10. A Gravely product registration card is supplied with each Gravely Product. Please complete the card and return it to Gravely at the address listed on the card. The equipment registration card will be used by Gravely for:
  - a. Recording date of purchase.
  - b. Notification of owners in compliance with the Consumer Product Safety Act, should any notification be necessary.

The return of such card is necessary for your warranty to be effective.
11. This Warranty is not subject to change or modification by anyone, including Gravely dealers and no Gravely dealer is authorized to make any representations or promises on Gravely's behalf.



One Gravely Lane, Clemmons, NC 27012